

Operation

Residential/Commercial Generator Sets

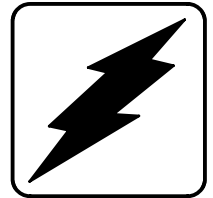

Models:

17RES

Controller:

Advanced Digital Control ADC-RES

KOHLER[®]
POWER SYSTEMS

ISO 9001
KOHLER
POWER SYSTEMS
NATIONALLY REGISTERED

TP-6515 10/07

California Proposition 65

⚠ WARNING

Engine exhaust from this product contains chemicals known to the State of California to cause cancer, birth defects, or other reproductive harm.

Product Identification Information

Product identification numbers determine service parts. Record the product identification numbers in the spaces below immediately after unpacking the products so that the numbers are readily available for future reference. Record field-installed kit numbers after installing the kits.

Generator Set Identification Numbers

Record the product identification numbers from the generator set nameplate(s).

Model Designation _____
 Specification Number _____
 Serial Number _____

Accessory Number	Accessory Description
_____	_____
_____	_____
_____	_____
_____	_____
_____	_____
_____	_____
_____	_____
_____	_____
_____	_____
_____	_____
_____	_____
_____	_____
_____	_____
_____	_____
_____	_____
_____	_____
_____	_____
_____	_____
_____	_____
_____	_____
_____	_____
_____	_____
_____	_____
_____	_____
_____	_____

Controller Identification

Record the controller description from the generator set operation manual, spec sheet, or sales invoice.

Controller Description _____

Engine Identification

Record the product identification information from the engine nameplate.

Manufacturer _____
 Model Designation _____
 Serial Number _____

Table of Contents

Product Identification Information	2
Safety Precautions and Instructions	5
Introduction	9
Service Assistance	10
Section 1 Features	11
1.1 Specifications	11
1.2 Generator	11
1.3 Engine	11
1.4 Advanced Digital Control	11
1.5 Generator Set Components	12
Section 2 Operation	13
2.1 Prestart Checklist	13
2.2 Exercising Generator Set	13
2.3 ADC-RES Controls and Indicators	13
2.3.1 LED Display	13
2.3.2 Controller Keypad	14
2.3.3 Generator Set Master Switch	14
2.4 Controller Power	15
2.4.1 Standby Mode	15
2.4.2 Sleep Mode	15
2.5 Generator Set Operation	15
2.5.1 Starting Generator Set	15
2.5.2 Stopping Generator Set	15
2.6 Faults	16
2.6.1 Shutdowns	16
2.6.2 Warnings	16
2.6.3 Resetting Controller after a Fault Shutdown	16
2.7 Battery Charger	18
2.7.1 Battery Charger Operation	18
Section 3 Scheduled Maintenance	19
3.1 Routine Maintenance	19
3.2 Service Schedule	20
3.3 Lubrication System	21
3.3.1 Low Oil Pressure Shutdown	21
3.3.2 Oil Check	21
3.3.3 Engine Oil Recommendation	21
3.3.4 Oil Change Procedure	21
3.3.5 Oil Cooler	22
3.4 Spark Plugs	22
3.5 Air Cleaner Service	23
3.6 Cooling System	23
3.7 Exhaust System	24
3.8 Battery	24
3.9 Battery Charger	25
3.10 Circuit Protection	25
3.10.1 Line Circuit Breaker	25
3.10.2 Fuses	25

Table of Contents, continued

3.11	Storage Procedure	26
3.11.1	Lubricating System	26
3.11.2	Fuel System	26
3.11.3	Cylinder Lubrication	26
3.11.4	Exterior Preparation	26
3.11.5	Battery	26
Section 4	Troubleshooting	27
4.1	Introduction	27
4.2	Controller Troubleshooting	27
4.3	Generator Set Troubleshooting	28
4.4	Battery Charger Troubleshooting	29
Appendix A	Abbreviations	31

Safety Precautions and Instructions

IMPORTANT SAFETY INSTRUCTIONS. Electromechanical equipment, including generator sets, transfer switches, switchgear, and accessories, can cause bodily harm and pose life-threatening danger when improperly installed, operated, or maintained. To prevent accidents be aware of potential dangers and act safely. Read and follow all safety precautions and instructions. **SAVE THESE INSTRUCTIONS.**

This manual has several types of safety precautions and instructions: Danger, Warning, Caution, and Notice.

DANGER

Danger indicates the presence of a hazard that **will cause severe personal injury, death, or substantial property damage.**

WARNING

Warning indicates the presence of a hazard that **can cause severe personal injury, death, or substantial property damage.**

CAUTION

Caution indicates the presence of a hazard that **will or can cause minor personal injury or property damage.**

NOTICE

Notice communicates installation, operation, or maintenance information that is safety related but not hazard related.

Safety decals affixed to the equipment in prominent places alert the operator or service technician to potential hazards and explain how to act safely. The decals are shown throughout this publication to improve operator recognition. Replace missing or damaged decals.

Accidental Starting

WARNING

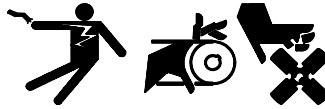

**Accidental starting.
Can cause severe injury or death.**

Disconnect the battery cables before working on the generator set. Remove the negative (-) lead first when disconnecting the battery. Reconnect the negative (-) lead last when reconnecting the battery.

Disabling the generator set. Accidental starting can cause severe injury or death. Before working on the generator set or connected equipment, disable the generator set as follows: (1) Move the generator set master switch to the OFF position. (2) Disconnect the power to the battery charger. (3) Remove the battery cables, negative (-) lead first. Reconnect the negative (-) lead last when reconnecting the battery. Follow these precautions to prevent starting of the generator set by an automatic transfer switch, remote start/stop switch, or engine start command from a remote computer.

Battery

WARNING



**Sulfuric acid in batteries.
Can cause severe injury or death.**

Wear protective goggles and clothing. Battery acid may cause blindness and burn skin.

WARNING



**Explosion.
Can cause severe injury or death.
Relays in the battery charger
cause arcs or sparks.**

Locate the battery in a well-ventilated area. Isolate the battery charger from explosive fumes.

Battery electrolyte is a diluted sulfuric acid. Battery acid can cause severe injury or death. Battery acid can cause blindness and burn skin. Always wear splashproof safety goggles, rubber gloves, and boots when servicing the battery. Do not open a sealed battery or mutilate the battery case. If battery acid splashes in the eyes or on the skin, immediately flush the affected area for 15 minutes with large quantities of clean water. Seek immediate medical aid in the case of eye contact. Never add acid to a battery after placing the battery in service, as this may result in hazardous spattering of battery acid.

Battery acid cleanup. Battery acid can cause severe injury or death. Battery acid is electrically conductive and corrosive. Add 500 g (1 lb.) of bicarbonate of soda (baking soda) to a container with 4 L (1 gal.) of water and mix the neutralizing solution. Pour the neutralizing solution on the spilled battery acid and continue to add the neutralizing solution to the spilled battery acid until all evidence of a chemical reaction (foaming) has ceased. Flush the resulting liquid with water and dry the area.

Battery gases. Explosion can cause severe injury or death. Battery gases can cause an explosion. Do not smoke or permit flames or sparks to occur near a battery at any time, particularly when it is charging. Do not dispose of a battery in a fire. To prevent burns and sparks that could cause an explosion, avoid touching the battery terminals with tools or other metal objects. Remove all jewelry before servicing the equipment. Discharge static electricity from your body before touching batteries by first touching a grounded metal surface away from the battery. To avoid sparks, do not disturb the battery charger connections while the battery is charging. Always turn the battery charger off before disconnecting the battery connections. Ventilate the compartments containing batteries to prevent accumulation of explosive gases.

Battery short circuits. Explosion can cause severe injury or death. Short circuits can cause bodily injury and/or equipment damage. Disconnect the battery before generator set installation or maintenance. Remove all jewelry before servicing the equipment. Use tools with insulated handles. Remove the negative (-) lead first when disconnecting the battery. Reconnect the negative (-) lead last when reconnecting the battery. Never connect the negative (-) battery cable to the positive (+) connection terminal of the starter solenoid. Do not test the battery condition by shorting the terminals together.

Engine Backfire/Flash Fire

⚠ WARNING

<p>Fire. Can cause severe injury or death.</p> <p>Do not smoke or permit flames or sparks near fuels or the fuel system.</p>

Servicing the air cleaner. A sudden backfire can cause severe injury or death. Do not operate the generator set with the air cleaner removed.

Servicing the fuel system. A flash fire can cause severe injury or death. Do not smoke or permit flames or sparks near the carburetor, fuel line, fuel filter, fuel pump, or other potential sources of spilled fuels or fuel vapors. Catch fuels in an approved container when removing the fuel line or carburetor.

Combustible materials. A fire can cause severe injury or death. Generator set engine fuels and fuel vapors are flammable and explosive. Handle these materials carefully to minimize the risk of fire or explosion. Equip the compartment or nearby area with a fully charged fire extinguisher. Select a fire extinguisher rated ABC or BC for electrical fires or as recommended by the local fire code or an authorized agency. Train all personnel on fire extinguisher operation and fire prevention procedures.

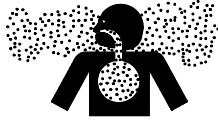
Exhaust System

⚠ WARNING

<p>Carbon monoxide. Can cause severe nausea, fainting, or death.</p> <p>The exhaust system must be leakproof and routinely inspected.</p>

Generator set operation. Carbon monoxide can cause severe nausea, fainting, or death. Carbon monoxide is an odorless, colorless, tasteless, nonirritating gas that can cause death if inhaled for even a short time. Avoid breathing exhaust fumes when working on or near the generator set. Never operate the generator set inside a building. Never operate the generator set where exhaust gas could seep inside or be drawn into a potentially occupied building through windows, air intake vents, or other openings.

Carbon monoxide symptoms. Carbon monoxide can cause severe nausea, fainting, or death. Carbon monoxide is a poisonous gas present in exhaust gases. Carbon monoxide is an odorless, colorless, tasteless, nonirritating gas that can cause death if inhaled for even a short time. Carbon monoxide poisoning symptoms include but are not limited to the following:

- Light-headedness, dizziness
- Physical fatigue, weakness in joints and muscles
- Sleepiness, mental fatigue, inability to concentrate or speak clearly, blurred vision
- Stomachache, vomiting, nausea

If experiencing any of these symptoms and carbon monoxide poisoning is possible, seek fresh air immediately and remain active. Do not sit, lie down, or fall asleep. Alert others to the possibility of carbon monoxide poisoning. Seek medical attention if the condition of affected persons does not improve within minutes of breathing fresh air.

Fuel System

WARNING

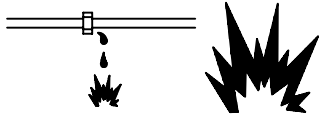

Explosive fuel vapors.
Can cause severe injury or death.

Use extreme care when handling, storing, and using fuels.

Gas fuel leaks. Explosive fuel vapors can cause severe injury or death. Fuel leakage can cause an explosion. Check the LP vapor gas or natural gas fuel system for leakage by using a soap and water solution with the fuel system test pressurized to 6–8 ounces per square inch (10–14 inches water column). Do not use a soap solution containing either ammonia or chlorine because both prevent bubble formation. A successful test depends on the ability of the solution to bubble.

Hazardous Noise

CAUTION



Hazardous noise.
Can cause hearing loss.

Never operate the generator set without a muffler or with a faulty exhaust system.

Engine noise. Hazardous noise can cause hearing loss. Generator sets not equipped with sound enclosures can produce noise levels greater than 105 dBA. Prolonged exposure to noise levels greater than 85 dBA can cause permanent hearing loss. Wear hearing protection when near an operating generator set.

Hazardous Voltage/ Moving Parts

WARNING



Hazardous voltage. Moving parts.
Can cause severe injury or death.

Operate the generator set only when all guards and electrical enclosures are in place.

WARNING



Hazardous voltage.
Backfeed to the utility system can cause property damage, severe injury, or death.

If the generator set is used for standby power, install an automatic transfer switch to prevent inadvertent interconnection of standby and normal sources of supply.

CAUTION



Welding the generator set.
Can cause severe electrical equipment damage.

Never weld components of the generator set without first disconnecting the battery, controller wiring harness, and engine electronic control module (ECM).

Grounding electrical equipment. Hazardous voltage can cause severe injury or death. Electrocutation is possible whenever electricity is present. Ensure you comply with all applicable codes and standards. Electrically ground the generator set, transfer switch, and related equipment and electrical circuits. Turn off the main circuit breakers of all power sources before servicing the equipment. Never contact electrical leads or appliances when standing in water or on wet ground because these conditions increase the risk of electrocution.

Welding on the generator set. Can cause severe electrical equipment damage. Before welding on the generator set perform the following steps: (1) Remove the battery cables, negative (-) lead first. (2) Disconnect all engine electronic control module (ECM) connectors. (3) Disconnect all generator set controller and voltage regulator circuit board connectors. (4) Disconnect the engine battery-charging alternator connections. (5) Attach the weld ground connection close to the weld location.

Connecting the battery and the battery charger. Hazardous voltage can cause severe injury or death. Reconnect the battery correctly, positive to positive and negative to negative, to avoid electrical shock and damage to the battery charger and battery(ies). Have a qualified electrician install the battery(ies).

Short circuits. Hazardous voltage/current can cause severe injury or death. Short circuits can cause bodily injury and/or equipment damage. Do not contact electrical connections with tools or jewelry while making adjustments or repairs. Remove all jewelry before servicing the equipment.

Electrical backfeed to the utility. Hazardous backfeed voltage can cause severe injury or death. Install a transfer switch in standby power installations to prevent the connection of standby and other sources of power. Electrical backfeed into a utility electrical system can cause severe injury or death to utility personnel working on power lines.

⚠ WARNING



Airborne particles.
Can cause severe injury or blindness.

Wear protective goggles and clothing when using power tools, hand tools, or compressed air.

Heavy Equipment

⚠ WARNING



Unbalanced weight.
Improper lifting can cause severe injury or death and equipment damage.

Do not use lifting eyes.
Lift the generator set using lifting bars inserted through the lifting holes on the skid.

Hot Parts

⚠ WARNING



Hot engine and exhaust system.
Can cause severe injury or death.

Do not work on the generator set until it cools.

Servicing the exhaust system. Hot parts can cause severe injury or death. Do not touch hot engine parts. The engine and exhaust system components become extremely hot during operation.

Servicing the engine heater. Hot parts can cause minor personal injury or property damage. Install the heater before connecting it to power. Operating the heater before installation can cause burns and component damage. Disconnect power to the heater and allow it to cool before servicing the heater or nearby parts.

Notice

NOTICE

Canadian installations only. For standby service connect the output of the generator set to a suitably rated transfer switch in accordance with Canadian Electrical Code, Part 1.

This manual provides operation and maintenance instructions for model 17RES generator sets equipped with the Kohler® ADC-RES Advanced Digital Control.

This generator set is approved for use in stationary applications in locations served by a reliable utility power source. Have the generator set installed by an authorized distributor/dealer or service technician. Refer to TP-6514, Installation Manual, for installation instructions.

Information in this publication represents data available at the time of print. The manufacturer may provide this manual for models not listed on the front cover. Kohler Co. reserves the right to change this publication and the products represented without notice and without any obligation or liability whatsoever.

Read this manual and carefully follow all procedures and safety precautions to ensure proper equipment operation and to avoid bodily injury. Read and follow the Safety Precautions and Instructions section at the beginning of this manual. Keep this manual with the equipment for future reference.

The equipment service requirements are very important to safe and efficient operation. Inspect the parts often and perform required service at the prescribed intervals. Obtain service from an authorized service distributor/dealer to keep equipment in top condition.

Nameplate

The following illustration shows a typical generator set nameplate. Copy the model, serial, and specification numbers from the nameplate into the spaces provided in the product information section on the inside front cover of this manual. See Section 1.5, Service Views, for the nameplate location.

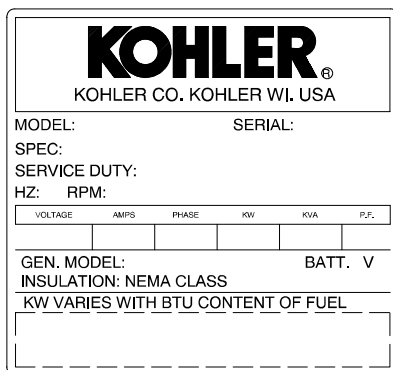

Emission Compliance

An engine or generator set with the following identification label is certified to meet Small Off-Road Engine emission standards for EPA/CARB.

This engine/generator is certified to operate using natural gas or propane fuel.

The 17RES generator set engine is certified to meet emission regulations for U.S. EPA phase 2 small off-road engines and CA 2006 and later LSI engines (large spark-ignited engines at or below 1 liter).



Figure 1 Engine Identification Label

The Emission Compliance Period referred to on the Engine Identification label indicates the number of operating hours for which the engine has been shown to meet EPA emission requirements. The engine compliance period (in hours), associated with the Category A descriptor found on the certification label, is 1000 hours.

Refer to the certification label for engine displacement.

The exhaust emission control system for the CH980 engine is EM.

Service Assistance

For professional advice on generator set power requirements and conscientious service, please contact your nearest Kohler distributor or dealer.

- Consult the Yellow Pages under the heading Generators—Electric.
- Visit the Kohler Power Systems website at KohlerPower.com.
- Look at the labels and stickers on your Kohler product or review the appropriate literature or documents included with the product.
- Call toll free in the US and Canada 1-800-544-2444.
- Outside the US and Canada, call the nearest regional office.

Headquarters Europe, Middle East, Africa (EMEA)

Kohler Power Systems
ZI Senia 122
12, rue des Hauts Flouviars
94517 Thiais Cedex
France
Phone: (33) 1 41 735500
Fax: (33) 1 41 735501

Asia Pacific

Power Systems Asia Pacific Regional Office
Singapore, Republic of Singapore
Phone: (65) 6264-6422
Fax: (65) 6264-6455

China

North China Regional Office, Beijing
Phone: (86) 10 6518 7950
(86) 10 6518 7951
(86) 10 6518 7952
Fax: (86) 10 6518 7955

East China Regional Office, Shanghai
Phone: (86) 21 6288 0500
Fax: (86) 21 6288 0550

India, Bangladesh, Sri Lanka

India Regional Office
Bangalore, India
Phone: (91) 80 3366208
(91) 80 3366231
Fax: (91) 80 3315972

Japan, Korea

North Asia Regional Office
Tokyo, Japan
Phone: (813) 3440-4515
Fax: (813) 3440-2727

Latin America

Latin America Regional Office
Lakeland, Florida, USA
Phone: (863) 619-7568
Fax: (863) 701-7131

1.1 Specifications

The generator set specification sheets provide specific generator and engine information. Refer to the spec sheet for data not supplied in this manual. Consult the generator set service manual, engine operation manual, and engine service manual for additional specifications. Obtain copies of the latest spec sheets, manuals, diagrams, and drawings from your local distributor/dealer.

1.2 Generator

The generator uses Kohler's unique PowerBoost™ voltage regulation system, which provides instant response to load changes.

PowerBoost™ ensures reliable motor starting and consistent voltage levels. PowerBoost™ utilizes a voltage excitation system that employs a winding independent of the main output windings to provide excitation voltage.

1.3 Engine

The generator set has a four-cycle, twin cylinder, air-cooled Kohler® engine. The engine operates on clean-burning natural gas or propane (LP) vapor. Engine features include:

- Efficient overhead valve design and full pressure lubrication for maximum power, torque, and reliability under all operating conditions.
- Dependable, maintenance-free electronic ignition.
- Precision-formulated cast iron construction of parts subjected to the most wear and tear.
- Field-convertible multi-fuel systems that allow fuel changeover from natural gas to LP vapor (and vice-versa) while maintaining CARB emission certification.
- Digital spark advance optimizes ignition timing for the selected fuel.

1.4 Advanced Digital Control

The generator set is equipped with the Kohler® ADC-RES Advanced Digital Control. Controller features include the following:

- Compact controller
- Integrally mounted to the generator set
- LED display:
 - Engine runtime, hours
 - AC voltage
 - Frequency (Hz)
 - Engine temperature
 - Battery voltage
 - Crank cycle status
 - Setup information
 - Application software version
- LED display communicates faults:
 - High battery voltage
 - High engine temperature
 - Low battery voltage
 - Low oil pressure
 - Overcrank safety
 - Overfrequency
 - Overspeed
 - Overvoltage
 - Underfrequency
 - Undervoltage
- Membrane keypad for configuration and adjustment
 - Password-protected user access to menus
 - Voltage, gain, and speed adjustment
 - System configuration (system voltage, phase, and frequency settings, battery voltage, and generator set model)
- Remote two-wire start/stop capability
- Digital isochronous governor to maintain steady-state speed at all loads
- Digital voltage regulation: $\pm 1.5\%$ RMS no-load to full-load
- Automatic start for programmed cranking cycle
- Master control switch mounted on the junction box: Run/Off-Reset/Auto
- Upgradeable application software

1.5 Generator Set Components

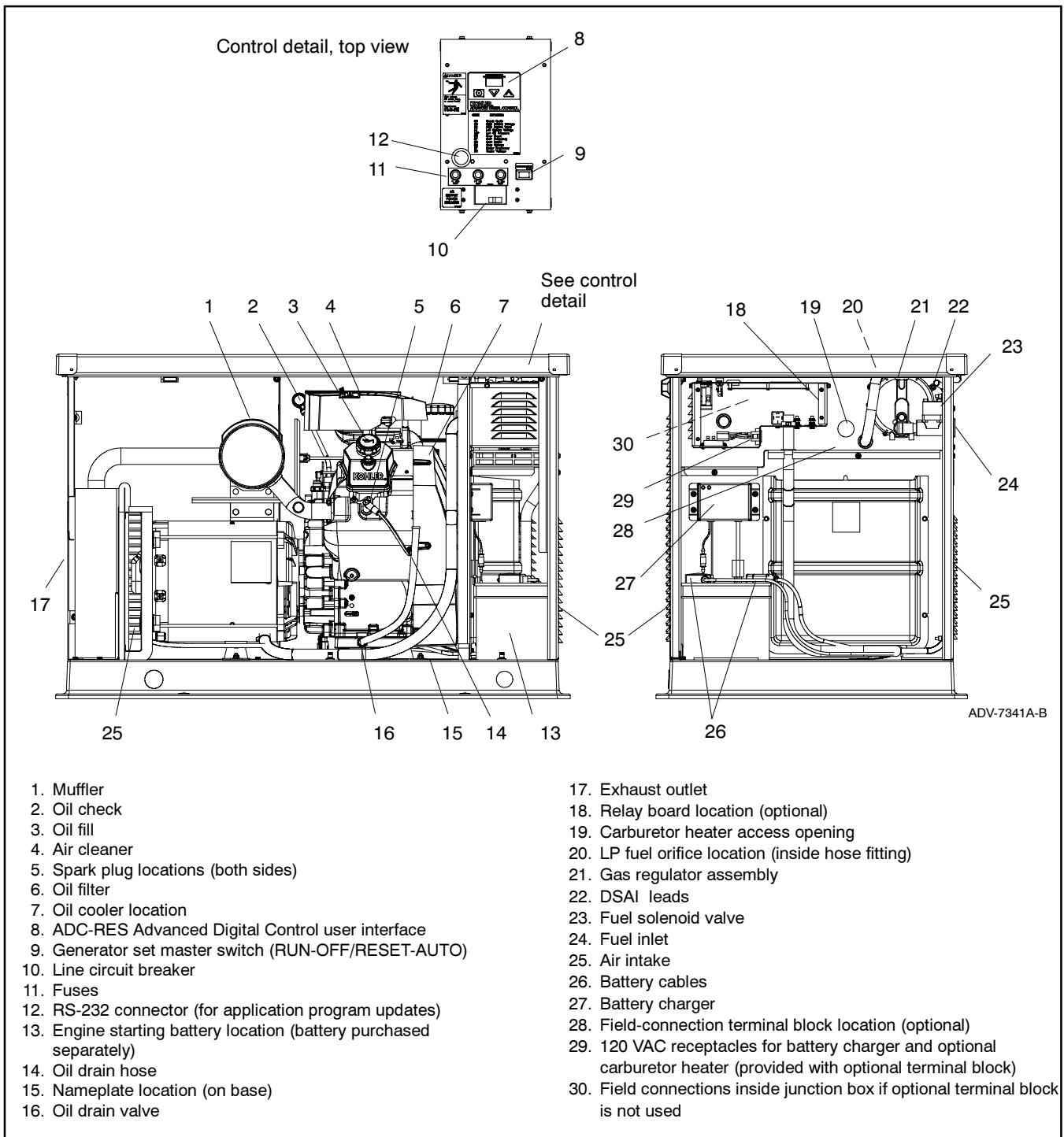

Figure 1-1 Generator Set Components

2.1 Prestart Checklist

To ensure continued satisfactory operation, perform the following checks or inspections before or at each startup, as designated, and at the intervals specified in the service schedule. In addition, some checks require verification after the unit starts.

Air Cleaner. Check for a clean and installed air cleaner element to prevent unfiltered air from entering the engine.

Air Inlets. Check for clean and unobstructed air inlets.

Battery. Check for tight battery connections. Consult the battery manufacturer's instructions regarding battery care and maintenance.

Exhaust System. Check for exhaust leaks and blockages. Check the muffler condition and check for tight exhaust system connections.

Inspect the exhaust system components for cracks, leaks, and corrosion.

- Check for corroded or broken metal parts and replace them as needed.
- Check that the exhaust outlet is unobstructed.

Oil Level. Maintain the oil level at or near, not over, the full mark on the dipstick.

Operating Area. Check for obstructions that could block the flow of cooling air. Keep the air intake area clean. Do not leave rags, tools, or debris on or near the generator set.

2.2 Exercising Generator Set

Operate the generator set without load once each week for 20 minutes. If the generator set is not connected to an automatic transfer switch (ATS) with an exercise option, exercise the unit in the presence of an operator.

The operator should perform all of the prestart checks before starting the exercise procedure. Start the generator set according to the starting procedure in the controller section of this manual. While the generator set is operating, listen for a smooth-running engine and visually inspect the generator set for fluid or exhaust leaks. Check the air inlets and outlets and remove any items restricting the air flow.

2.3 ADC-RES Controls and Indicators

Figure 2-1 illustrates the ADC-RES user interface and other items on the generator set junction box. Figure 2-3 describes the ADC-RES controls and indicators.

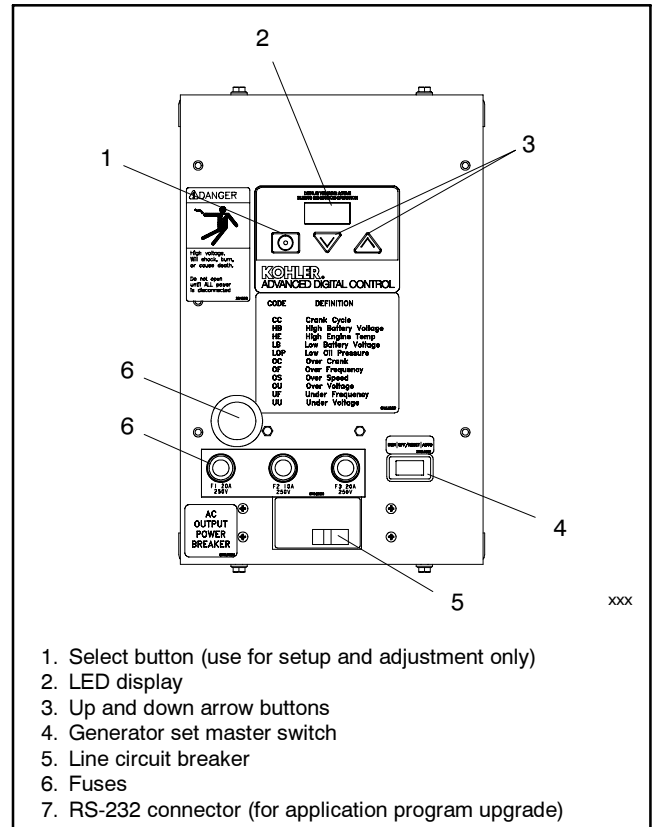

Figure 2-1 ADC-RES Controls

2.3.1 LED Display

The LED display is activated by a start or RUN command as follows:

- Move the master switch to RUN.
- With the master switch in AUTO, send a remote start command (close the remote start contact across leads 3 and 4).

The LED display indicates generator set status as shown in Figure 2-3. When the generator set is running, engine runtime hours are shown unless the arrow

buttons are used to step through the other displays as described in Section 2.3.2.

When the master switch is in AUTO, the display turns off 48 hours after generator set shutdown. See Section 2.4.

2.3.2 Controller Keypad

The three buttons on the controller keypad are Select, Up, and Down.

When the generator set is running, the up and down arrow buttons can be used to step through system data displays as shown in Figure 2-2. After 10 seconds, the display returns to engine runtime hours.

The buttons on the controller keypad are also used for system configuration and adjustment. The system configuration is factory-set and should not require changes under normal operating conditions. Contact an authorized distributor/dealer or service technician if adjustments are required.

2.3.3 Generator Set Master Switch

The generator set master switch is located on the junction box below the ADC-RES user interface. The master switch positions are RUN, OFF/RESET, and AUTO. See Section 2.5 for operation instructions.

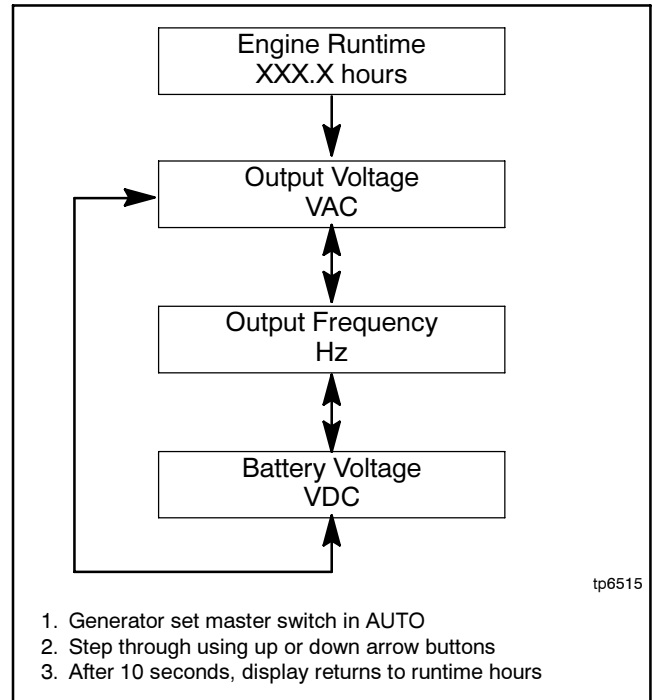

Figure 2-2 Data Displays

Control or Indicator	Item	Description
LED display	Runtime hours	Displays total generator set runtime hours while the generator set is running and when no other codes are displayed.
	Metering display	Displays AC voltage (output), frequency, and battery voltage. Press the up or down arrow when runtime hours are displayed to step through these displays.
	Crank indication	Displays CC_1, CC_2, or CC_3 to indicate the first, second, or third attempt to start the engine. The last digit flashes during the crank cycle rest periods.
	Software version number	The software version number (v#.##) is displayed when entering configuration mode. See the Installation Manual.
	Fault codes	Flashes a 2- or 3-letter fault code to indicate various fault conditions. See Section 2.6.
Keypad	Select and arrow buttons	Use the arrow buttons to step through the data displays. See Figure 2-2. The keypad is also used for controller setup and adjustment. The setup and adjustment functions are password-protected. Have setup and adjustments performed only by an authorized distributor/dealer.
Generator set master switch	Three-position switch	Switch functions as the generator set operation and controller reset switch.

Figure 2-3 ADC-RES Controls and Indicators

2.4 Controller Power

The ADC-RES is powered by the generator set engine starting battery.

Note: The generator sets are equipped with factory-installed battery chargers to prevent battery discharge. The battery charger must be connected to 120 VAC.

2.4.1 Standby Mode

When the generator set master switch is in the AUTO position, the controller is in standby mode. Engine runtime hours are shown on the display. A remote start signal (contact closure) will start and run the generator set.

If there is no start signal for 48 hours, the controller goes into sleep mode.

2.4.2 Sleep Mode

When the generator set master switch is in the AUTO position, the controller powers down automatically if there is no start signal for 48 hours after shutdown. The controller display is dark and battery draw is minimized. A remote start signal (from a transfer switch or a remote start/stop switch connected to controller leads 3 and 4) reactivates the controller. Moving the generator set master switch to the RUN position also activates the controller.

2.5 Generator Set Operation

2.5.1 Starting Generator Set

Local Starting

Move the generator set master switch to the RUN position to immediately start the generator set.

Auto (Automatic) Starting

Move the generator set master switch to the AUTO position to allow startup by an automatic transfer switch (ATS) or remote start/stop switch, if equipped. Close a contact across engine start leads 3 and 4 to signal the controller to start the generator set.

Crank Cycle

The controller attempts to start the generator set three times (three crank cycles, 15 seconds crank and 15 seconds off). See Figure 2-3 for display information during the crank cycle. If the generator set does not start in three attempts, the system shuts down on an overcrank fault. See Section 2.6.

2.5.2 Stopping Generator Set

Local Stopping

1. Run the generator set with no load for at least 2 minutes to ensure adequate engine cooldown.
2. Move the generator set master switch to the OFF/RESET position. The engine stops.

Automatic Stopping

With the generator set master switch in the AUTO position, open the contact across engine start leads 3 and 4 to signal the generator set to stop.

An automatic transfer switch (ATS) connected to controller leads 3 and 4 operates as follows:

1. The ATS disconnects the load from the generator set.
2. If the ATS is equipped with an engine cooldown time delay, the generator set continues to run for a preset engine cooldown time.

Note: There is no engine cooldown time delay on the ADC-RES controller.

3. The ATS opens the connection between controller leads 3 and 4. The generator set shuts down. The controller enters standby mode and displays engine runtime hours.

2.6 Faults

2.6.1 Shutdowns

Under the fault shutdown conditions listed in Figure 2-4, the generator set shuts down automatically and the controller displays a fault code. The generator set cannot be restarted until the fault condition is corrected and the controller is reset. See Section 2.6.3 to reset the controller after a fault shutdown.

The shutdown switches on the generator set will automatically reset when the problem is corrected. For example, the high engine temperature switch resets automatically when the generator set cools. However, the fault does not clear until the controller is reset.

2.6.2 Warnings

The controller displays a fault code but the generator set does not shut down on a high battery voltage warning or a low battery voltage warning. The controller resets automatically after a battery voltage fault condition is corrected.

2.6.3 Resetting Controller after a Fault Shutdown

Always identify and correct the cause of a fault shutdown before resetting the controller. Check the fault code displayed on the ADC-RES and refer to Figure 2-4 to identify and correct the fault condition before proceeding.

Use the following procedure to reset the generator set controller after a fault shutdown.

1. Move the generator set master switch to OFF/RESET.
2. Disconnect the generator set from the load using the line circuit breaker or ATS. See the safety precautions at the beginning of this manual before proceeding.
3. Identify and correct the cause of the fault shutdown. See the safety precautions at the beginning of this manual before proceeding. Refer to Section 4, Troubleshooting.
4. Start the generator set by moving the generator set master switch to RUN. Test operate the generator set to verify that the cause of the shutdown has been corrected.
5. Move the generator set master switch to OFF/RESET.
6. Reconnect the generator set to the load using the line circuit breaker or ATS.
7. Move the generator set master switch to the AUTO position for startup by remote transfer switch or remote start/stop switch.

Note: The controller's LED display remains off until an engine start command is received.

Code	Fault	Description	Check
AF	Auxiliary fault input shutdown	Not used.	—
HE	High engine temperature shutdown	Shutdown occurs if the engine coolant temperature exceeds the maximum temperature for more than 5 seconds. This protective becomes active after the engine reaches the crank disconnect speed.	Check for blocked air inlets and exhaust outlets.
LOP	Low oil pressure shutdown	Shutdown occurs if a low oil pressure condition exists for more than 5 seconds. This protective becomes active 30 seconds after the engine has reached crank disconnect speed (30 second inhibit). Note: The low oil pressure shutdown does not protect against low oil level. Check the oil level at the engine.	Check for leaks in the lubrication system. Check the oil level and add oil if the level is low.
OC	Overcrank shutdown	Shutdown occurs after 3 unsuccessful starting attempts. The crank cycle is set for three starting attempts of 15 seconds cranking and 15 seconds rest.	Check the fuel supply, spark plug, and battery. Check for loose connections.
	Locked rotor	The generator set also shuts down on OC if no engine rotation is sensed during cranking. Shuts down 3 seconds after the fault is detected.	Contact an authorized distributor/dealer for service if problem continues.
OF	Overfrequency shutdown	Shutdown occurs when the governed frequency exceeds 110% of the system's frequency setpoint for more than 5 seconds. This protective becomes active 10 seconds after engine start (10 second inhibit).	Contact an authorized distributor/dealer for service if problem continues.
OS	Overspeed shutdown	Shutdown occurs if the engine speed exceeds 110% of the normal running speed for more than 0.3 seconds.	Contact an authorized distributor/dealer for service if problem continues.
OU	Overvoltage shutdown	Shutdown occurs if the voltage exceeds 120% of the system nominal voltage for more than 2 seconds.	Contact an authorized distributor/dealer for service if problem continues.
UF	Underfrequency shutdown	Shutdown occurs if the governed frequency falls below 54 Hz for more than 5 seconds. Shutdown also occurs if the governed frequency falls below 56.5 Hz for more than 60 seconds. This protective becomes active 10 seconds after engine start. (10 second inhibit).	Reduce the load and restart the generator set. Contact an authorized distributor/dealer for service if problem continues.
UU	Undervoltage shutdown	Shutdown occurs if the voltage falls below 80% of the nominal system voltage for more than 10 seconds.	Reduce the load and restart the generator set. Contact an authorized distributor/dealer for service if problem continues.
HB	High battery voltage warning	Fault code is displayed if the engine starting battery voltage rises above 16 VDC for more than 30 seconds when the engine is running. Not operative during the engine crank cycle, this fault condition does not inhibit engine starting. The fault condition clears when the battery voltage returns to an acceptable level.	Check the battery rating and condition. Check the battery charger operation.
LB	Low battery voltage warning	Fault code is displayed if the engine starting battery voltage falls below 11 VDC for more than 30 seconds when the engine is not running. Not operative during the engine crank cycle, this fault condition does not inhibit engine starting. The fault condition clears when the battery voltage returns to an acceptable level.	Check the battery rating and condition. Check the battery charger operation. Charge or replace the battery.

Figure 2-4 ADC-RES Fault Codes

2.7 Battery Charger

The generator set is equipped with a 6-amp float/equalize battery charger to maintain the engine starting battery. The charger's power cord must be connected to a 120 VAC power source. Figure 2-5 illustrates the battery charger.

The battery charger uses an AGS 10 inline fuse. The fuse is located in the battery lead. See Figure 2-5.

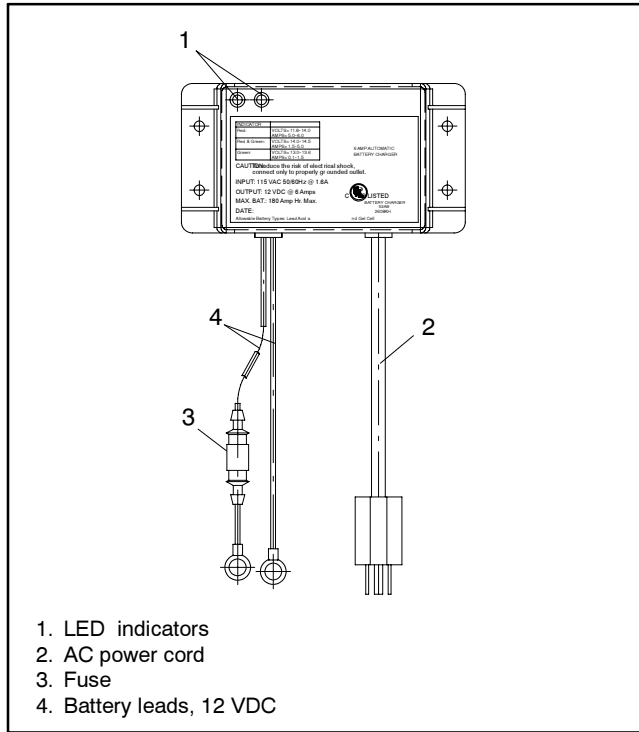

Figure 2-5 6-Amp Float/Equalize Battery Charger

2.7.1 Battery Charger Operation

Figure 2-6 illustrates the three-stage charging method. Red and green LEDs indicate charger operation. The chart in Figure 2-7 describes the LED indicator operation during each stage of the charging process.

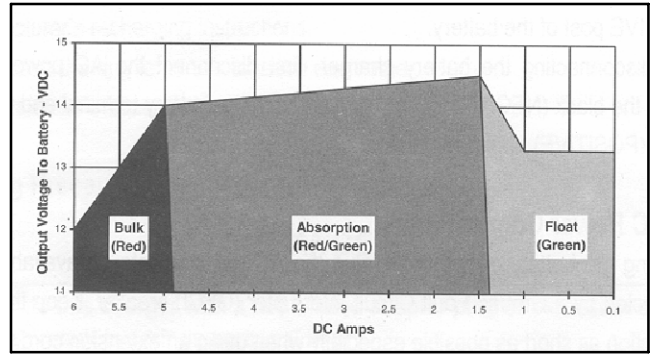

Figure 2-6 Charging Method

Display	Operating Condition
Red ON Green OFF	When the red LED is on, it indicates the battery is discharged and the battery charger is recharging at the BULK rate (stage 1). This charging rate is 6 amps. While the red LED is on, the voltage measured (with the battery charger on) will be 11.8–14 volts. If the red LED stays on for more than 24 hours, refer to Section 4.4 in this manual.
Red ON Green ON	When both the green and the red LEDs are on, the battery charger is charging at an ABSORPTION rate of between 1.5 and 5 amps (stage 2). This mode of charging gradually tops off your battery, and reduces harmful sulfating. While both LEDs are on, the voltage measured (with the battery charger on) should be approximately 14.0–14.5 VDC. If both LEDs stay on longer than 24 hours, refer to Section 4.4 in this manual.
Red OFF Green ON	When the green LED is on, the battery charger is charging at a FLOAT or MAINTENANCE rate of less than 1.5 amps (stage 3). Your battery is now 90% charged and ready for use. This float charging current will gradually decrease to as low as 0.1 amps as the battery reaches 100% charge. It will now be kept at full charge without overcharging. If the green LED stays on when your battery is known to be low, refer to Section 4.4 in this manual.

Figure 2-7 Battery Charger LED Indicator Functions

Section 3 Scheduled Maintenance

⚠ WARNING

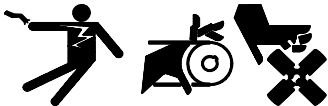

**Accidental starting.
Can cause severe injury or death.**

Disconnect the battery cables before working on the generator set. Remove the negative (-) lead first when disconnecting the battery. Reconnect the negative (-) lead last when reconnecting the battery.

Disabling the generator set. Accidental starting can cause severe injury or death. Before working on the generator set or connected equipment, disable the generator set as follows: (1) Move the generator set master switch to the OFF position. (2) Disconnect the power to the battery charger. (3) Remove the battery cables, negative (-) lead first. Reconnect the negative (-) lead last when reconnecting the battery. Follow these precautions to prevent starting of the generator set by an automatic transfer switch, remote start/stop switch, or engine start command from a remote computer.

⚠ WARNING





**Hot engine and exhaust system.
Can cause severe injury or death.**

Do not work on the generator set until it cools.

Servicing the exhaust system. Hot parts can cause severe injury or death. Do not touch hot engine parts. The engine and exhaust system components become extremely hot during operation.

⚠ WARNING



**Hazardous voltage. Moving parts.
Can cause severe injury or death.**

Operate the generator set only when all guards and electrical enclosures are in place.

Servicing the generator set when it is operating. Exposed moving parts can cause severe injury or death. Keep hands, feet, hair, clothing, and test leads away from the belts and pulleys when the generator set is running. Replace guards, screens, and covers before operating the generator set.

3.1 Routine Maintenance

Refer to the following service schedule and the runtime hours displayed on the ADC-RES display to schedule routine maintenance. Intervals are shown in hours of operation and/or time intervals (i.e. weekly, monthly, quarterly, etc.) Have an authorized distributor/ dealer service the generator set at the designated intervals in the service schedule for the life of the generator set. Service units subject to extreme weather, long operating hours, or dusty or dirty conditions more frequently.

Contact an authorized distributor/dealer for parts.

3.2 Service Schedule

System Component or Procedure	See Section	Procedure				
		Visually Inspect	Check	Change	Clean	Test
Fuel						
Flexible lines and connections		Q		R		
Main tank supply level			W			
Fuel piping		Y				
Lubrication	3.3					
Oil level	3.3.2		8 or E			
Change oil	3.3.4			Y or 150		
Replace filter	3.3.4			Y or 150		
Crankcase breather hose		Y or 500				
Oil cooler	3.3.5	Y			Y or 100	
Cooling	3.6					
Air ducts, louvers			Y		Y	
Exhaust System	3.7					
Leakage		W	W			
Insulation, fire hazards		Y				
Obstructions or combustible materials near exhaust outlet		W				
DC Electrical System	3.8					
Battery charger operation, charge rate		M				
Remove corrosion, clean and dry battery and rack		Y			Y	
Clean and tighten battery terminals and inspect boots		Y	Y			
Battery electrolyte level and specific gravity *			Y			
AC Electrical System						
Tighten control and power wiring connections			Y			
Remote control system, if equipped						M
Visible wear or damage		Q				
Wire abrasions where subject to motion		6 months	6 months			
Wire-cable insulation condition		3Y or 500				
Engine and Mounting						
Visible wear or damage		W				
Air cleaner service †	3.5		150	300		
Spark plugs	3.4		150	300		
Replace stepper motor coupling and bushing	S/M			500 (D)		
Generator						
Visible wear or damage	2.1	Q				
Exercise generator set	2.2					W
Brushes and collector ring	S/M	Y (D)			Y (D)	
Measure and record resistance readings of windings with insulation tester (Megger®, with SCR assembly or rectifier and load leads disconnected)	S/M					3Y (D)
General Condition of Equipment						
Evidence of vibration, leakage, deterioration, unusual or excessive noise or temperature		W	W		W	
Interior of sound enclosure		Q			Q	
* Not necessary for maintenance-free batteries. † Service more frequently under extremely dusty/dirty conditions. Megger® is a registered trademark of Biddle Instruments.		E Each use W Weekly M Monthly Q Quarterly Y Yearly	Number = hours of operation D Authorized distributor/dealer only R Replace as necessary S/M Service Manual			

3.3 Lubrication System

See Section 3.2, Service Schedule, for oil change and oil filter replacement intervals. See Section 1.5, Service Views, for the oil drain, oil check, oil fill, and oil filter locations.

3.3.1 Low Oil Pressure Shutdown

The low oil pressure (LOP) shutdown feature protects the engine against internal damage if the oil pressure drops below a minimum pressure because of oil pump failure or other malfunction.

Note: The LOP shutdown feature does not protect against damage caused by operating when the oil level is low; it is not a low oil level shutdown. Check the oil level regularly, and add oil as needed.

3.3.2 Oil Check

The generator set is shipped with oil. Before operating the generator set, check the engine oil in the crankcase. See Figure 3-1 for the dipstick location.

Maintain the oil level at or near, not over, the full mark on the dipstick. Add 5W-30 synthetic oil when the oil level is low. See Section 3.3.3, Engine Oil Recommendation.

Check the oil level before each use. For extended operation, check the oil level every 8 hours. Do not check the oil level when the generator set is running. Shut down the generator set and wait several minutes before checking the oil.

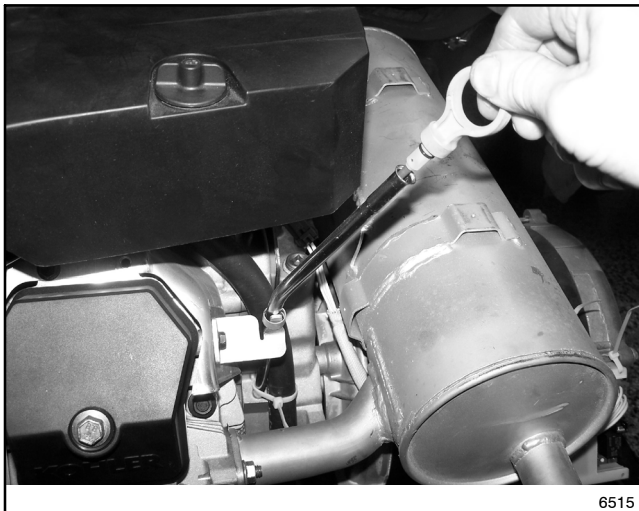

Figure 3-1 Oil Check

3.3.3 Engine Oil Recommendation

Use 5W-30 API (American Petroleum Institute) Service Class SG, SH, or SJ synthetic oil. Synthetic oil oxidizes

and thickens less than other oils and leaves the engine intake valves and pistons cleaner.

3.3.4 Oil Change Procedure

Note: Dispose of all waste materials (engine oil, fuel, filter, etc.) in an environmentally safe manner.

Drain the oil while it is still warm.

1. Drain the oil.

- a. Place the generator set master switch in the OFF position.
- b. Disconnect the power to the battery charger.
- c. Disconnect the generator set engine starting battery, negative (-) lead first.
- d. Remove the housing side panel.
- e. Clean the area around the dipstick and oil fill cap.
- f. Remove the oil drain hose from its retaining clip. Remove the cap from the oil drain hose and lower the hose into an oil collection container.
- g. Open the oil drain valve on the engine.
- h. Remove the dipstick and oil fill cap. Allow time for the engine oil to drain completely.
- i. Close the oil drain valve. Replace the cap on the oil drain hose. Replace the oil drain hose in its retaining clip.
- j. Replace the dipstick.

2. Replace the oil filter.

- a. Clean the area around the oil filter. Remove the oil filter by rotating it counterclockwise with an oil filter wrench.
- b. Clean the gasket sealing surface of the oil filter adapter.
- c. Apply a light coat of clean oil to the rubber seal of the new oil filter.
- d. Install the new oil filter following the instructions provided with the filter.

3. Fill with oil.

- a. Fill the engine to the F mark on the dipstick. The engine oil capacity is approximately 2.8 L (3.0 qt.). See Section 3.3.3, Engine Oil Recommendation, for oil selection.
- b. Reinstall the dipstick and the oil fill cap.
- c. Check that the generator set master switch is in the OFF position.
- d. Reconnect the generator set engine starting battery, negative (-) lead last.
- e. Reconnect the power to the battery charger.
- f. Start and run the generator set for a minute to allow the oil pressure to reach operating range.
- g. Stop the generator set, wait 1 minute, and then recheck the oil level. Add oil to bring the level up to the F mark on the dipstick.

4. Check for leaks.

- a. Check for oil leaks.
- b. Fix leaks and recheck the oil level.
- c. Reinstall the housing side panel.

3.3.5 Oil Cooler

Inspect and clean the oil cooler at the intervals indicated in the service schedule. The oil cooler must be kept free of debris.

See Figure 3-2 for the oil cooler location. The oil cooler is located under the No. 2 cylinder shroud. Remove the top mounting screw and loosen the two side screws, then lift off the cylinder shroud.

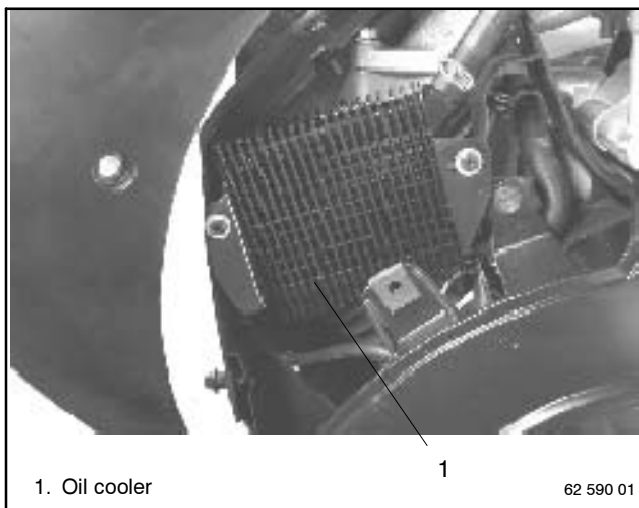

Figure 3-2 Oil Cooler Location

Clean the outside of the oil cooler fins with a brush or with compressed air.

3.4 Spark Plugs

Reset the spark plug gap or replace the plugs with new plugs as necessary.

1. Clean the area around the base of the spark plug to keep dirt and debris out of the engine.
2. Remove the spark plug and check its condition. Replace the spark plug if it is worn or if its reuse is questionable.
3. Check the spark plug gap using a wire feeler gauge. Adjust the gap to 0.76 mm (0.030 in.) by carefully bending the ground electrode. See Figure 3-3 and Figure 3-4.
4. Reinstall the spark plug into the cylinder head. Torque the spark plug to 24.4-29.8 Nm (18-22 ft. lb.)

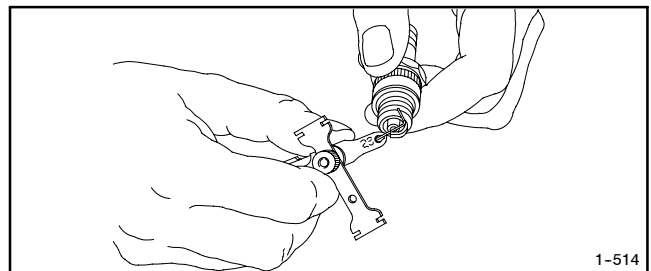

Figure 3-3 Checking the Spark Plug Gap

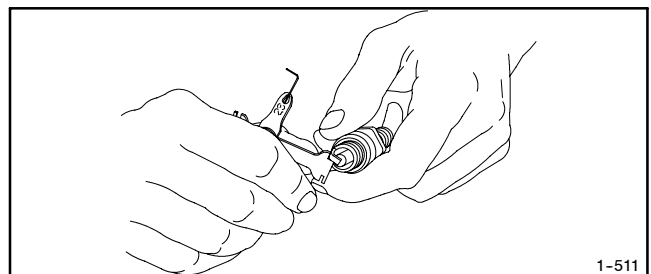

Figure 3-4 Adjusting the Spark Plug Gap

3.5 Air Cleaner Service

The engine is equipped with a replaceable, high density paper air cleaner element. See Figure 3-5.

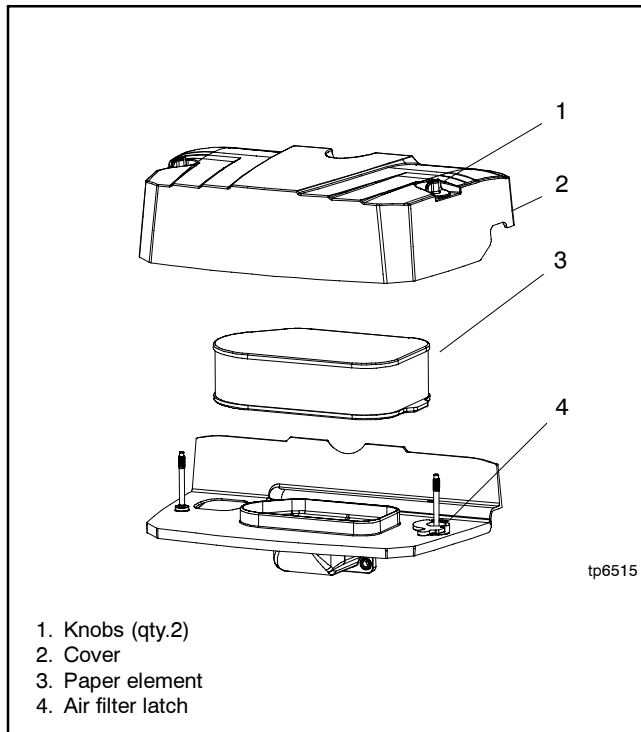

Figure 3-5 Air Cleaner Components

Check the air cleaner daily or before starting the engine. Check for a buildup of dirt and debris around the air cleaner system. Keep this area clean. Also check for loose or damaged components. Replace all bent or damaged air cleaner components.

Note: Operating the engine with loose or damaged air cleaner components could allow unfiltered air into the engine causing premature wear and failure.

Paper Element Service

Replace the paper element at the intervals indicated in the service schedule. See Section 3.2 for the service schedule. See Figure 3-5 for the air cleaner components.

1. Loosen the two cover retaining knobs and remove the cover.
2. Rotate the air filter latch counterclockwise to unlock, then remove the paper element.
3. Do not wash the paper element or use pressurized air, as this will damage the element. Replace a dirty, bent, or damaged element with a genuine

Kohler element. Handle new elements carefully; do not use if the sealing surfaces are bent or damaged.

4. When servicing the air cleaner, check the air cleaner base and latch. Make sure it is secured and not bent or damaged. Also, check the element cover for damage or improper fit. Replace all damaged air cleaner components.

Note: If any loose dirt or debris fell on the air cleaner base when the element was removed, carefully remove it and wipe the base clean. Be careful that none of it drops into the intake throat.

5. Reinstall the paper element onto the air cleaner base. Make sure the element is flat and properly seated. Rotate the latch clockwise, over the molded lip on the element.
6. Install the air cleaner cover and secure with the two retaining knobs.
7. When element replacement is necessary, order genuine Kohler parts.

3.6 Cooling System

The engine fan draws cooling air through the openings in the sides and end near the battery. The alternator fan draws cooling air through openings on the side walls of the enclosure. The cooling air mixes with the engine exhaust and is discharged at the exhaust outlet. See Figure 3-6. To prevent generator set damage caused by overheating, keep the housing cooling inlets and outlets clean and unobstructed at all times.

Note: Do not block the generator set cooling air inlets or mount other equipment above them. Overheating and severe generator damage may occur.

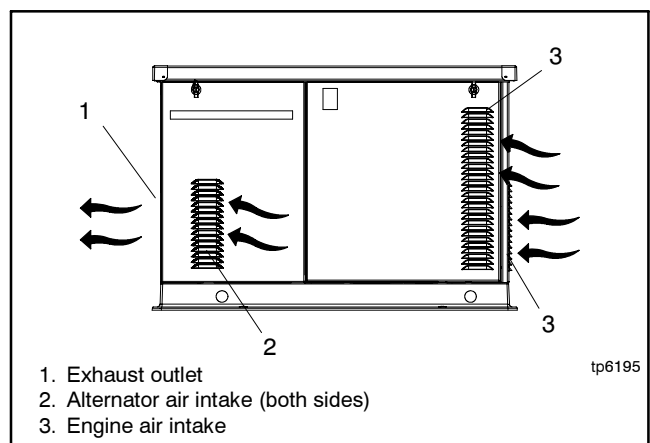

Figure 3-6 Cooling Air Intake and Exhaust

3.7 Exhaust System

Remove all combustible materials from the exhaust location. Combustible materials include building materials as well as natural surroundings. Keep dry field grass, foliage, and combustible landscaping material a minimum of 1.5 m (5 ft.) from the exhaust outlet.

Periodically inspect the exhaust system components for cracks, leaks, and corrosion.

- Check for corroded or broken metal parts and replace them as needed.
- Check that the exhaust outlet is clear.

3.8 Battery

⚠ WARNING



**Sulfuric acid in batteries.
Can cause severe injury or death.**

Wear protective goggles and clothing. Battery acid may cause blindness and burn skin.

Battery electrolyte is a diluted sulfuric acid. Battery acid can cause severe injury or death. Battery acid can cause blindness and burn skin. Always wear splashproof safety goggles, rubber gloves, and boots when servicing the battery. Do not open a sealed battery or mutilate the battery case. If battery acid splashes in the eyes or on the skin, immediately flush the affected area for 15 minutes with large quantities of clean water. Seek immediate medical aid in the case of eye contact. Never add acid to a battery after placing the battery in service, as this may result in hazardous spattering of battery acid.

Battery acid cleanup. Battery acid can cause severe injury or death. Battery acid is electrically conductive and corrosive. Add 500 g (1 lb.) of bicarbonate of soda (baking soda) to a container with 4 L (1 gal.) of water and mix the neutralizing solution. Pour the neutralizing solution on the spilled battery acid and continue to add the neutralizing solution to the spilled battery acid until all evidence of a chemical reaction (foaming) has ceased. Flush the resulting liquid with water and dry the area.

Battery gases. Explosion can cause severe injury or death. Battery gases can cause an explosion. Do not smoke or permit flames or sparks to occur near a battery at any time, particularly when it is charging. Do not dispose of a battery in a fire. To prevent burns and sparks that could cause an explosion, avoid touching the battery terminals with tools or other metal objects. Remove all jewelry before servicing the equipment. Discharge static electricity from your body before touching batteries by first touching a grounded metal surface away from the battery. To avoid sparks, do not disturb the battery charger connections while the battery is charging. Always turn the battery charger off before disconnecting the battery connections. Ventilate the compartments containing batteries to prevent accumulation of explosive gases.

Battery short circuits. Explosion can cause severe injury or death. Short circuits can cause bodily injury and/or equipment damage. Disconnect the battery before generator set installation or maintenance. Remove all jewelry before servicing the equipment. Use tools with insulated handles. Remove the negative (-) lead first when disconnecting the battery. Reconnect the negative (-) lead last when reconnecting the battery. Never connect the negative (-) battery cable to the positive (+) connection terminal of the starter solenoid. Do not test the battery condition by shorting the terminals together.

Refer to this section for general battery information and maintenance. Also consult the battery manufacturer's instructions for battery maintenance.

All generator set models use a negative ground with a 12-volt engine electrical system. Consult the generator set nameplate for the engine electrical system voltage. Consult the generator spec sheet for battery capacity recommendations for replacement purposes. Wiring diagrams provide battery connection information. See Figure 3-7 for typical battery connections.

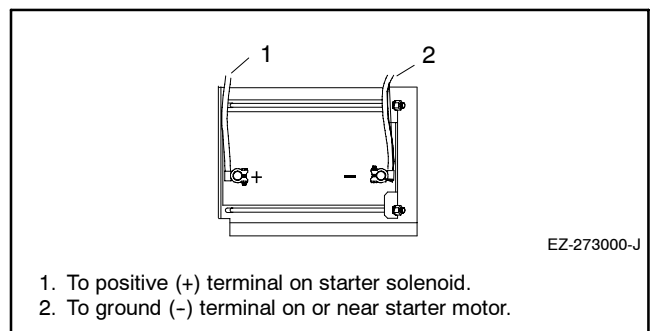

Figure 3-7 12-Volt Engine Electrical System Single Starter Motor, Typical Battery Connection

Clean the battery and cables and tighten battery terminals using the service schedule recommendations. To prevent corrosion, maintain tight, dry electrical connections at the battery terminals. To remove corrosion from battery terminals, disconnect the cables from the battery and scrub the terminals with a wire brush. Clean the battery and cables with a solution of baking soda and water. After cleaning, flush the battery and cables with clean water and wipe them with a dry, lint-free cloth.

After reconnecting the battery cables, coat the battery terminals with petroleum jelly, silicone grease, or other nonconductive grease.

3.9 Battery Charger

The generator set is equipped with a 6-amp float/equalize battery charger to maintain the engine starting battery. Figure 3-8 illustrates the battery charger.

The charger's DC leads are factory-wired. Periodically tighten all connections.

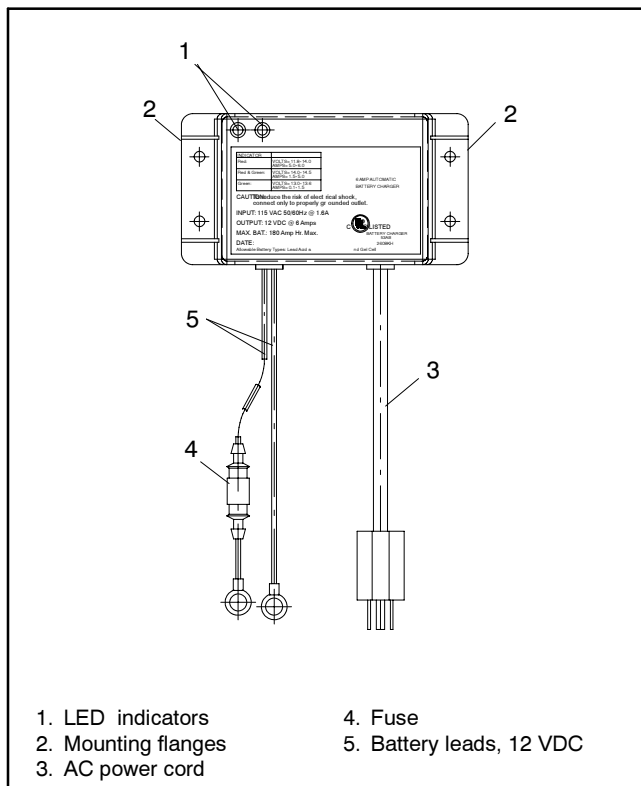

Figure 3-8 6-Amp Float/Equalize Battery Charger

3.10 Circuit Protection

If the generator set circuit breaker trips or the fuses blow repeatedly, see Section 4, Troubleshooting, for possible causes.

3.10.1 Line Circuit Breaker

A line circuit breaker interrupts the generator output in the event of a fault in the wiring between the generator and the load. The line circuit breaker location is shown in Figure 1-1. The circuit breaker rating is shown in Figure 3-9. If the circuit breaker trips, reduce the load and switch the breaker back to the ON position. With the breaker in the OFF position the generator set runs but the generator output is disconnected from the load.

Model	Circuit Breaker Rating, Amp
17RES	70

Figure 3-9 Line Circuit Breaker Rating

3.10.2 Fuses

Three panel-mounted fuses protect the alternator and electrical controls. See Section 1.5 for fuse locations. Another 10-amp fuse protects the battery charger. See Figure 3-8 for the battery charger fuse location.

See Figure 3-10 for fuse part numbers. Always identify and correct the cause of a blown fuse before restarting the generator set. Refer to Section 4, Troubleshooting, for conditions that may indicate a blown fuse. Replace blown fuses with identical replacement parts.

Fuse	Rating, Amp	Label	Part Number
Auxiliary winding	20	F1	292937
Relay interface board	10	F2	223316
Controller	10	F3	223316
Battery charger	10	—	AGS 10

Figure 3-10 Fuses

3.11 Storage Procedure

Perform the following storage procedure before removing the generator set from service for three months or longer. Follow the engine manufacturer's recommendations for storage, if available.

Note: Run the generator set monthly whenever possible.

3.11.1 Lubricating System

1. Operate the generator set until it reaches operating temperature, or about 15 minutes.
2. Stop the generator set.
3. While the engine is still warm, drain the engine lubrication oil from the engine crankcase.
4. Refill the engine crankcase with oil. See Section 3.3.3 for oil recommendations.
5. Run the generator set for a few minutes to distribute the clean oil.
6. Stop the generator set.

3.11.2 Fuel System

1. Start the generator set.
2. With the generator set running, shut off the gas supply.
3. Run the generator set until the engine stops.
4. Place the generator set master switch in the OFF/RESET position.

3.11.3 Cylinder Lubrication

1. Remove the spark plugs.
2. Pour one tablespoon of engine oil into each spark plug hole. Install the spark plugs and *ground* the spark plug leads. *Do not connect the leads to the plugs.*
3. Toggle the generator set master switch to crank the engine two or three revolutions to lubricate the cylinders.

3.11.4 Exterior Preparation

1. Clean the exterior surface of the generator set.
2. Seal all openings in the engine with nonabsorbent adhesive tape.
3. Mask all areas to be used for electrical contact.
4. Spread a light film of oil over unpainted metallic surfaces to prevent rust and corrosion.

3.11.5 Battery

Perform battery storage last.

1. Place the generator set master switch in the OFF/RESET position.
2. Disconnect the battery, negative (-) lead first.
3. Clean the battery.
4. Place the battery in a warm, dry location.
5. Connect the battery to a float/equalize battery charger, or charge the battery monthly using a trickle charger. Follow the battery charger manufacturer's recommendations.

Section 4 Troubleshooting

4.1 Introduction

Use the following charts to diagnose and correct common problems. First check for simple causes such as a dead engine starting battery, loose connections, or an open circuit breaker. The charts include a list of common problems, possible causes of the problem, and recommended corrective actions.

If the procedures in this manual do not explain how to correct the problem, contact an authorized distributor/dealer. Maintain a record of repairs and adjustments performed on the equipment. Use the record to help describe the problem and repairs or adjustments made to the equipment.

4.2 Controller Troubleshooting

Figure 4-1 contains troubleshooting, diagnostic, and repair information for the ADC-RES controller.

Problem	Possible Cause	Corrective Action
Controller LED display is off	No power to the controller: The generator set has not run for 48 hours or longer and the controller has powered down. Controller fuse (F3) is blown. Low or no battery voltage.	Controller display will automatically activate when a remote start command is received or the generator set master switch is moved to the RUN position. See Section 2.4. Replace the fuse. If the fuse blows again, contact the distributor/dealer. Check connections. Check generator set battery and battery charger. See Figure 4-2.
	Generator set master switch is in the OFF/RESET position.	Move generator set master switch to the AUTO or RUN position. In AUTO, the display will not turn on until the first start command is received.
	Generator set master switch in AUTO but no start command has been received since last controller reset.	Controller display will activate when a remote start command is received or the generator set master switch is moved to the RUN position. Use the remote switch to start generator set and activate the controller display, if desired. See Section 2.3.1.

Figure 4-1 ADC-RES Troubleshooting Chart

4.3 Generator Set Troubleshooting

Figure 4-2 contains generator set troubleshooting, diagnostic, and repair information. Check for loose connections before replacing parts.

If a fault code is displayed, identify and correct the cause of the fault condition. Then reset the controller. See Section 2.6.3.

Fault Codes

The Advanced Digital Control displays fault codes to aid in troubleshooting. Fault codes, descriptions, and recommended actions are listed in Section 2.6.

Problem	Possible Cause	Corrective Action
The generator set does not crank.	Fault shutdown	Check for a fault code on the controller display. See Section 2.6.
	Battery weak or dead	Check power to the battery charger. Recharge or replace the battery.
	Battery charger fuse blown	Replace the fuse. Contact an authorized distributor/dealer for service if fuse blows repeatedly.
	Battery connections reversed or poor	Check the connections.
	Fuse F2 blown	Replace the fuse. Contact an authorized distributor/dealer for service if fuse blows repeatedly.
	Fuse F3 blown	Replace the fuse. Contact an authorized distributor/dealer for service if fuse blows repeatedly.
	Generator set master switch in the OFF position	Move the master switch to AUTO for remote start or to RUN for local start.
The generator set cranks but does not start, starts hard, lacks power, or operates erratically.	Air cleaner clogged	Clean and/or replace the air cleaner.
	Battery weak or dead	Check power to the battery charger. Recharge or replace the battery.
	Battery connection poor	Clean and tighten the battery connections.
	Spark plug wire connection loose	Check the spark plug wires.
	Low oil pressure shutdown	Check the oil level.
	Fuel pressure insufficient	Check the fuel supply and valves.
	Engine malfunction	Contact the distributor/dealer.
No AC output.	AC circuit breaker in the OFF position	Place the circuit breaker in the ON position.
	AC circuit breaker tripping because of overload	Reduce the load on the generator set.
	AC circuit breaker tripping because of short circuit	Contact an authorized distributor/dealer for service.
	Auxiliary winding fuse (F1) blown	Replace the fuse. Contact an authorized distributor/dealer for service if fuse blows repeatedly.
Low output or excessive drop in voltage.	Generator set overloaded	Reduce the load.
Generator set stops suddenly.	Low oil pressure shutdown	Check the oil level.
	Out of fuel	Check fuel supply.
	Overcrank shutdown	Reset the controller. If the overcrank fault occurs again, contact the distributor/dealer.
	Controller fuse (F3) blown	Replace the fuse. If the fuse blows again, contact the distributor/dealer.
	Overspeed shutdown	Reset the controller. If the overspeed fault occurs again, contact the distributor/dealer.
	Generator set master switch in the OFF/RESET position	Move the switch to the correct position (RUN or AUTO).
	Remote stop command received from a remote switch or ATS	Check the remote switch position.
	Engine malfunction	Contact the distributor/dealer.
Auxiliary winding fuse (F1) blown	Replace the fuse. Contact an authorized distributor/dealer for service if fuse blows repeatedly.	

Figure 4-2 General Troubleshooting Chart

4.4 Battery Charger Troubleshooting

Use the battery charger's LED indicators and the table in Figure 4-3 to troubleshoot battery charger operation problems.

Problem	Cause	Solution
Red LED stays on for more than 24 hours	One or more inoperative or damaged cells.	Load test the battery and replace, if necessary
	Battery charger has reduced its output voltage below the normal level due to a DC overload or a DC short.	Remove the source of the overload or short. Disconnect the battery charger's black (NEGATIVE) ring terminal from the battery. Reapply AC power and the green LED only should now light.
	Onboard DC systems are drawing more current than the battery charger can replace.	Turn off all DC equipment while charging.
Red and green LEDs stay on for more than 24 hours	Onboard DC systems are drawing between 1.5 and 5 amps.	Turn off all DC equipment while charging.
	One or more inoperative or damaged cells.	Load test the battery and replace, if necessary
	Extremely low AC voltage at the battery charger.	Apply a higher AC voltage source or reduce the length of the extension cord.
Green LED stays on when the battery is known to be low	Open DC output fuse.	Replace AGS-10 fuse.
	Faulty or contaminated terminal connections.	Clean and tighten or repair all terminal connections.
	One or more inoperative or damaged cells.	Load test the battery and replace, if necessary.
Neither of the LEDs turn on when the AC power is applied	No AC power available at the battery charger.	Connect AC power or reset the AC breaker on the main panel.
	Component failure.	Replace battery charger.

Figure 4-3 Battery Charger Troubleshooting

Notes

Appendix A Abbreviations

The following list contains abbreviations that may appear in this publication.

A, amp	ampere	cfm	cubic feet per minute	est.	estimated
ABDC	after bottom dead center	CG	center of gravity	E-Stop	emergency stop
AC	alternating current	CID	cubic inch displacement	etc.	et cetera (and so forth)
A/D	analog to digital	CL	centerline	exh.	exhaust
ADC	advanced digital control; analog to digital converter	cm	centimeter	ext.	external
adj.	adjust, adjustment	CMOS	complementary metal oxide substrate (semiconductor)	F	Fahrenheit, female
ADV	advertising dimensional drawing	cogen.	cogeneration	fglass.	fiberglass
Ah	amp-hour	com	communications (port)	FHM	flat head machine (screw)
AHWT	anticipatory high water temperature	coml	commercial	fl. oz.	fluid ounce
AISI	American Iron and Steel Institute	Coml/Rec	Commercial/Recreational	flex.	flexible
ALOP	anticipatory low oil pressure	conn.	connection	freq.	frequency
alt.	alternator	cont.	continued	FS	full scale
Al	aluminum	CPVC	chlorinated polyvinyl chloride	ft.	foot, feet
ANSI	American National Standards Institute (formerly American Standards Association, ASA)	crit.	critical	ft. lb.	foot pounds (torque)
AO	anticipatory only	CRT	cathode ray tube	ft./min.	feet per minute
APDC	Air Pollution Control District	CSA	Canadian Standards Association	ftp	file transfer protocol
API	American Petroleum Institute	CT	current transformer	g	gram
approx.	approximate, approximately	Cu	copper	ga.	gauge (meters, wire size)
AQMD	Air Quality Management District	cUL	Canadian Underwriter's Laboratories	gal.	gallon
AR	as required, as requested	CUL	Canadian Underwriter's Laboratories	gen.	generator
AS	as supplied, as stated, as suggested	cu. in.	cubic inch	genset	generator set
ASE	American Society of Engineers	cw.	clockwise	GFI	ground fault interrupter
ASME	American Society of Mechanical Engineers	CWC	city water-cooled	GND, ⊕	ground
assy.	assembly	cyl.	cylinder	gov.	governor
ASTM	American Society for Testing Materials	D/A	digital to analog	gph	gallons per hour
ATDC	after top dead center	DAC	digital to analog converter	gpm	gallons per minute
ATS	automatic transfer switch	dB	decibel	gr.	grade, gross
auto.	automatic	dB(A)	decibel (A weighted)	GRD	equipment ground
aux.	auxiliary	DC	direct current	gr. wt.	gross weight
avg.	average	DCR	direct current resistance	H x W x D	height by width by depth
AVR	automatic voltage regulator	deg., °	degree	HC	hex cap
AWG	American Wire Gauge	dept.	department	HCHT	high cylinder head temperature
AWM	appliance wiring material	DFMEA	Design Failure Mode and Effects Analysis	HD	heavy duty
bat.	battery	dia.	diameter	HET	high exhaust temp., high engine temp.
BBDC	before bottom dead center	DI/EO	dual inlet/end outlet	hex	hexagon
BC	battery charger, battery charging	DIN	Deutsches Institut fur Normung e. V. (also Deutsche Industrie Normenausschuss)	Hg	mercury (element)
BCA	battery charging alternator	DIP	dual inline package	HH	hex head
BCI	Battery Council International	DPDT	double-pole, double-throw	HHC	hex head cap
BDC	before dead center	DS	disconnect switch	HP	horsepower
BHP	brake horsepower	DVR	digital voltage regulator	hr.	hour
blk.	black (paint color), block (engine)	E, emer.	emergency (power source)	HS	heat shrink
blk. htr.	block heater	ECM	electronic control module, engine control module	hsg.	housing
BMEP	brake mean effective pressure	EDI	electronic data interchange	HVAC	heating, ventilation, and air conditioning
bps	bits per second	EFR	emergency frequency relay	HWT	high water temperature
br.	brass	e.g.	for example (<i>exempli gratia</i>)	Hz	hertz (cycles per second)
BTDC	before top dead center	EG	electronic governor	IC	integrated circuit
Btu	British thermal unit	EGSA	Electrical Generating Systems Association	ID	inside diameter, identification
Btu/min.	British thermal units per minute	EIA	Electronic Industries Association	IEC	International Electrotechnical Commission
C	Celsius, centigrade	EI/EO	end inlet/end outlet	IEEE	Institute of Electrical and Electronics Engineers
cal.	calorie	EMI	electromagnetic interference	IMS	improved motor starting
CAN	controller area network	emiss.	emission	in.	inch
CARB	California Air Resources Board	eng.	engine	in. H ₂ O	inches of water
CB	circuit breaker	EPA	Environmental Protection Agency	in. Hg	inches of mercury
cc	cubic centimeter	ES	engineering special, engineered special	in. lb.	inch pounds
CCA	cold cranking amps	ESD	electrostatic discharge	Inc.	incorporated
ccw.	counterclockwise			ind.	industrial
CEC	Canadian Electrical Code			int.	internal
cert.	certificate, certification, certified			int./ext.	internal/external
cfh	cubic feet per hour			I/O	input/output
				IP	iron pipe
				ISO	International Organization for Standardization
				J	joule
				JIS	Japanese Industry Standard

k	kilo (1000)	MTBO	mean time between overhauls	rms	root mean square
K	kelvin	mtg.	mounting	rnd.	round
kA	kiloampere	MTU	Motoren-und Turbinen-Union	ROM	read only memory
KB	kilobyte (2 ¹⁰ bytes)	MW	megawatt	rot.	rotate, rotating
KBus	Kohler communication protocol	mW	milliwatt	rpm	revolutions per minute
kg	kilogram	μF	microfarad	RS	right side
kg/cm ²	kilograms per square centimeter	N, norm.	normal (power source)	RTU	remote terminal unit
kgm	kilogram-meter	NA	not available, not applicable	RTV	room temperature vulcanization
kg/m ³	kilograms per cubic meter	nat. gas	natural gas	RW	read/write
kHz	kilohertz	NBS	National Bureau of Standards	SAE	Society of Automotive Engineers
kJ	kilojoule	NC	normally closed	scfm	standard cubic feet per minute
km	kilometer	NEC	National Electrical Code	SCR	silicon controlled rectifier
kOhm, kΩ	kilo-ohm	NEMA	National Electrical Manufacturers Association	s, sec.	second
kPa	kilopascal	NFPA	National Fire Protection Association	SI	<i>Systeme international d'unites</i> , International System of Units
kph	kilometers per hour	Nm	newton meter	SI/EO	side in/end out
kV	kilovolt	NO	normally open	sil.	silencer
kVA	kilovolt ampere	no., nos.	number, numbers	SN	serial number
kVAR	kilovolt ampere reactive	NPS	National Pipe, Straight	SNMP	simple network management protocol
kW	kilowatt	NPSC	National Pipe, Straight-coupling	SPDT	single-pole, double-throw
kWh	kilowatt-hour	NPT	National Standard taper pipe thread per general use	SPST	single-pole, single-throw
kWm	kilowatt mechanical	NPTF	National Pipe, Taper-Fine	spec	specification
kWth	kilowatt-thermal	NR	not required, normal relay	specs	specification(s)
L	liter	ns	nanosecond	sq.	square
LAN	local area network	OC	overcrank	sq. cm	square centimeter
L x W x H	length by width by height	OD	outside diameter	sq. in.	square inch
lb.	pound, pounds	OEM	original equipment manufacturer	SS	stainless steel
lbm/ft ³	pounds mass per cubic feet	OF	overfrequency	std.	standard
LCB	line circuit breaker	opt.	option, optional	stl.	steel
LCD	liquid crystal display	OS	oversize, overspeed	tach.	tachometer
ld. shd.	load shed	OSHA	Occupational Safety and Health Administration	TD	time delay
LED	light emitting diode	OV	overvoltage	TDC	top dead center
Lph	liters per hour	oz.	ounce	TDEC	time delay engine cooldown
Lpm	liters per minute	p., pp.	page, pages	TDEN	time delay emergency to normal
LOP	low oil pressure	PC	personal computer	TDES	time delay engine start
LP	liquefied petroleum	PCB	printed circuit board	TDNE	time delay normal to emergency
LPG	liquefied petroleum gas	pF	picofarad	TDOE	time delay off to emergency
LS	left side	PF	power factor	TDON	time delay off to normal
L _{wa}	sound power level, A weighted	ph., ∅	phase	temp.	temperature
LWL	low water level	PHC	Phillips® head Crimptite® (screw)	term.	terminal
LWT	low water temperature	PHH	Phillips® hex head (screw)	THD	total harmonic distortion
m	meter, milli (1/1000)	PHM	pan head machine (screw)	TIF	telephone influence factor
M	mega (10 ⁶ when used with SI units), male	PLC	programmable logic control	TIR	total indicator reading
m ³	cubic meter	PMG	permanent magnet generator	tol.	tolerance
m ³ /hr.	cubic meters per hour	pot	potentiometer, potential	turbo.	turbocharger
m ³ /min.	cubic meters per minute	ppm	parts per million	typ.	typical (same in multiple locations)
mA	milliampere	PROM	programmable read-only memory	UF	underfrequency
man.	manual	psi	pounds per square inch	UHF	ultrahigh frequency
max.	maximum	psig	pounds per square inch gauge	UL	Underwriter's Laboratories, Inc.
MB	megabyte (2 ²⁰ bytes)	pt.	pint	UNC	unified coarse thread (was NC)
MCCB	molded-case circuit breaker	PTC	positive temperature coefficient	UNF	unified fine thread (was NF)
MCM	one thousand circular mils	PTO	power takeoff	univ.	universal
meggar	megohmmeter	PVC	polyvinyl chloride	US	undersize, underspeed
MHz	megahertz	qt.	quart, quarts	UV	ultraviolet, undervoltage
mi.	mile	qty.	quantity	V	volt
mil	one one-thousandth of an inch	R	replacement (emergency) power source	VAC	volts alternating current
min.	minimum, minute	rad.	radiator, radius	VAR	voltampere reactive
misc.	miscellaneous	RAM	random access memory	VDC	volts direct current
MJ	megajoule	RDO	relay driver output	VFD	vacuum fluorescent display
mJ	millijoule	ref.	reference	VGA	video graphics adapter
mm	millimeter	rem.	remote	VHF	very high frequency
mOhm, mΩ	milliohm	Res/Coml	Residential/Commercial	W	watt
MOhm, MΩ	megohm	RFI	radio frequency interference	WCR	withstand and closing rating
MOV	metal oxide varistor	RH	round head	w/	with
MPa	megapascal	RHM	round head machine (screw)	w/o	without
mpg	miles per gallon	rly.	relay	wt.	weight
mph	miles per hour			xfrm	transformer
MS	military standard				
ms	millisecond				
m/sec.	meters per second				
MTBF	mean time between failure				

TP-6515 10/07

© 2007 by Kohler Co. All rights reserved.

KOHLER[®] POWER SYSTEMS

KOHLER CO. Kohler, Wisconsin 53044
Phone 920-565-3381, Fax 920-459-1646
For the nearest sales/service outlet in the
US and Canada, phone 1-800-544-2444
KohlerPower.com

Kohler Power Systems
Asia Pacific Headquarters
7 Jurong Pier Road
Singapore 619159
Phone (65) 6264-6422, Fax (65) 6264-6455