

Essential Electrical Concepts

Introduction Modern vehicles incorporate many electrical and electronic components and systems:

- Audio
- Lights
- Navigation
- Engine control
- Transmission control
- Braking and traction control

You need to know essential electrical concepts to effectively troubleshoot these and other electrical circuits.

Electrical and electronic system troubleshooting can be straightforward if ...

- You know what to look for.
- You know how to select and use the appropriate tools and test equipment.

With the knowledge and techniques you will learn in this course, you will be able to ...

- Diagnose and repair electrical and electronic problems correctly on the first attempt.
- Reduce diagnostic and repair time.
- Increase customer satisfaction.

Meters Different meters are used to measure voltage, current, and resistance:

- Voltmeter - to measure voltage
- Ammeter - to measure current
- Ohmmeter - to measure resistance

These three metering functions are combined into a single tester called a “multimeter.” Nearly all automotive technicians use multimeters.

A multimeter is often called a “volt-ohmmeter,” even though most multimeters also measure amperes (current).

A multimeter can be one of two types:

1. Analog - display uses a needle to point to a measured value on a scale.
2. Digital - display shows measured value in actual numbers (digits).

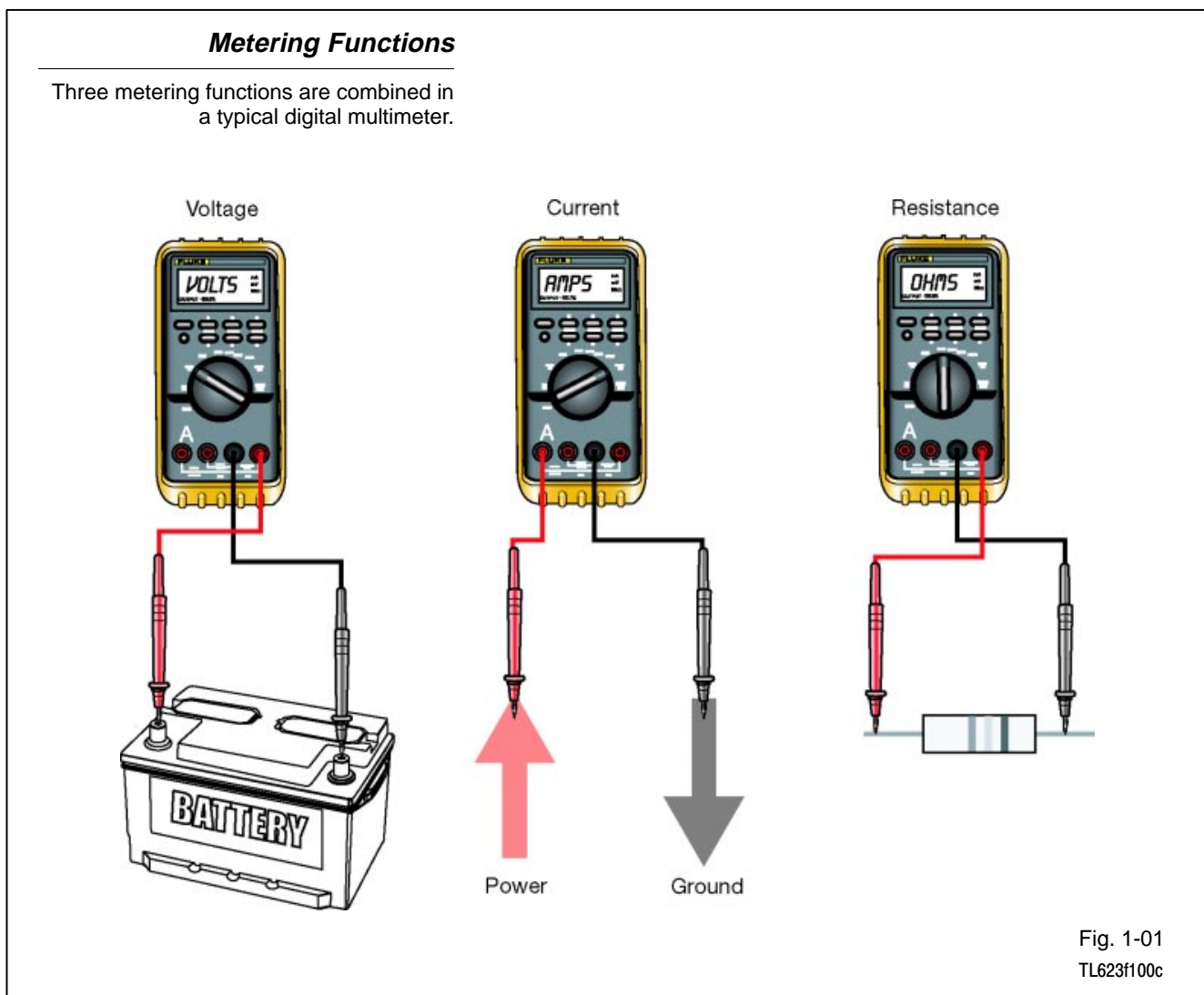

Analog Multimeters

Analog multimeters ...

- Use a mechanical movement to drive a pointer.
- Display a measured value where the pointer intersects a calibrated scale.
- Are not suitable for measurements in circuits with sensitive electronic components (such as ECUs).
- Are more susceptible to damage from mechanical shock than are digital multimeters.

Typical Analog Multimeter

Analog meters use a mechanical movement and are not suitable for measurements in circuits with sensitive electronic components.

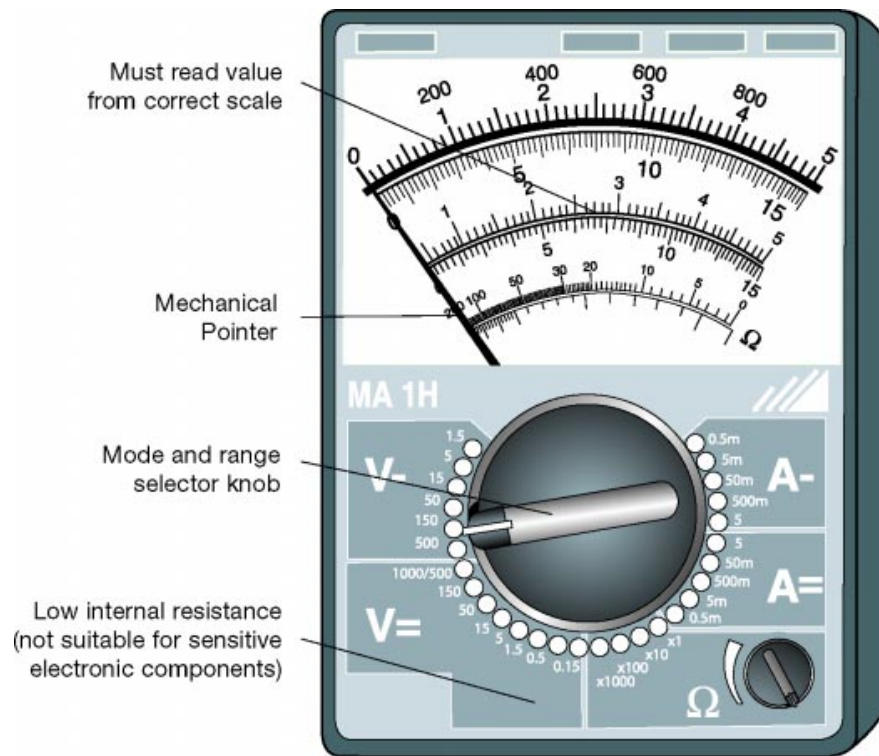

Fig. 1-02
TL623f102

Digital Multimeters Digital multimeters ...

- Use a digital display.
- Display a measured value in actual numbers.
- Are suitable for measurements in circuits with sensitive electronic components (such as ECUs).
- Are less susceptible to damage from mechanical shock than are analog multimeters.
- Have a longer battery life.
- Have a higher internal resistance.

Typical Digital Multimeter

Digital multimeters display the actual measured value and are suitable for measurements in circuits with sensitive electronic components.



Fig. 1-03
TL623f103c

DMM Components The main components found on the front panel of a typical digital multimeter (DMM) are ...

- Digital display
- Range selector
- Mode selector
- Input jacks

DMM Components

This figure shows the main components of a typical digital multimeter.

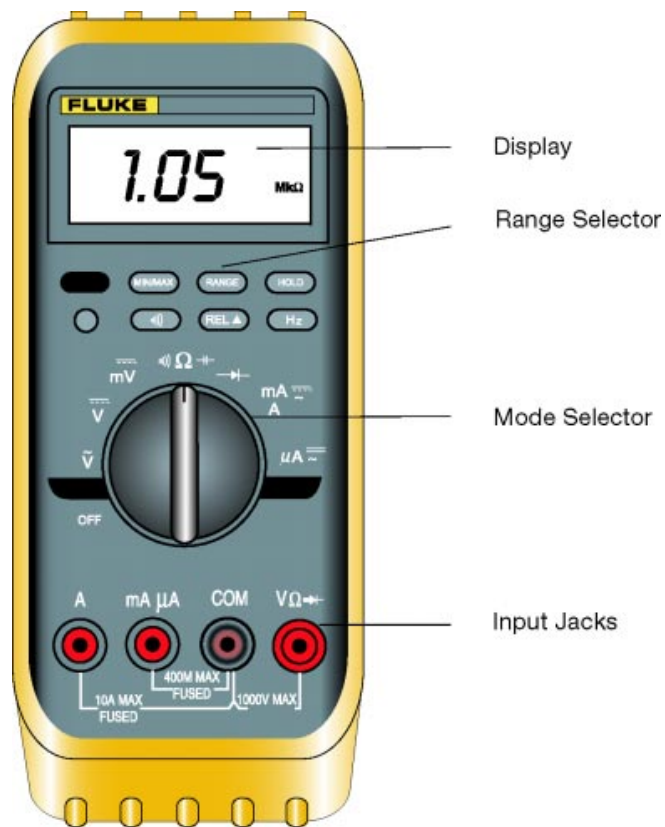
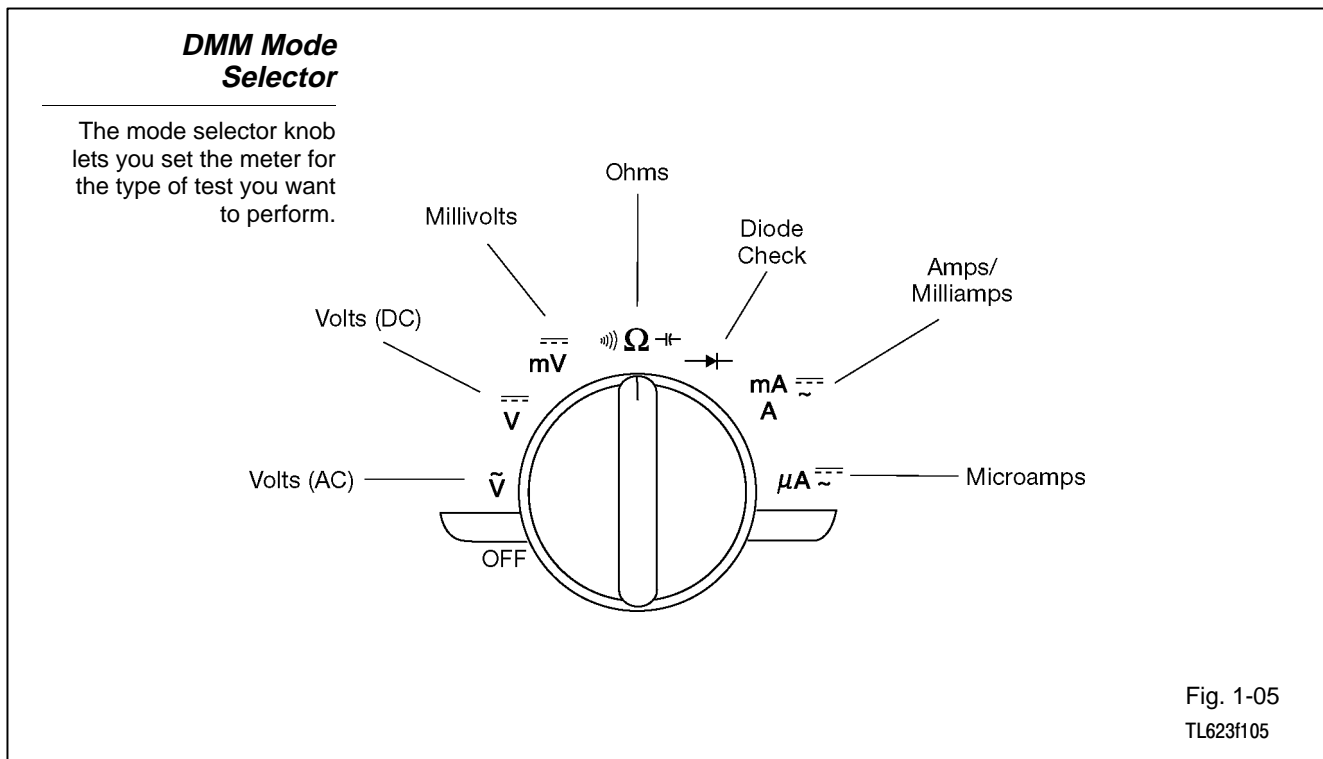

Fig. 1-04
TL623f104c

DMM Mode Selector Use the mode selector to set the meter for the type of test to be performed. These are the modes available on a Fluke 87 DMM:

- **Off** - Turns the meter off. Turning the mode selector to any other setting turns the meter on.
- **Volts AC** - Use to measure voltage in alternating current (AC) circuits.
- **Volts DC** - Use to measure voltage in direct current (DC) circuits.
- **Millivolts DC (mV) DC** - Use to measure very low voltage in direct current (DC) circuits.
- **Resistance/Continuity (ohms)** - Use to measure resistance and check continuity.
- **Diode Check** - Use to check the operation of a diode (meter sends a small current through the diode).
- **Amps or Milliamps AC/DC** - Use to measure current in a circuit.
- **Microamps (AC/DC)** - Use to measure very small current in a circuit.



DMM Display DMMs display information that must be properly interpreted to get the correct measured value.

Interpreting DMM Displays

The digital display gives a direct readout in actual numbers. However, you still must properly interpret the display to get the correct measurement value.

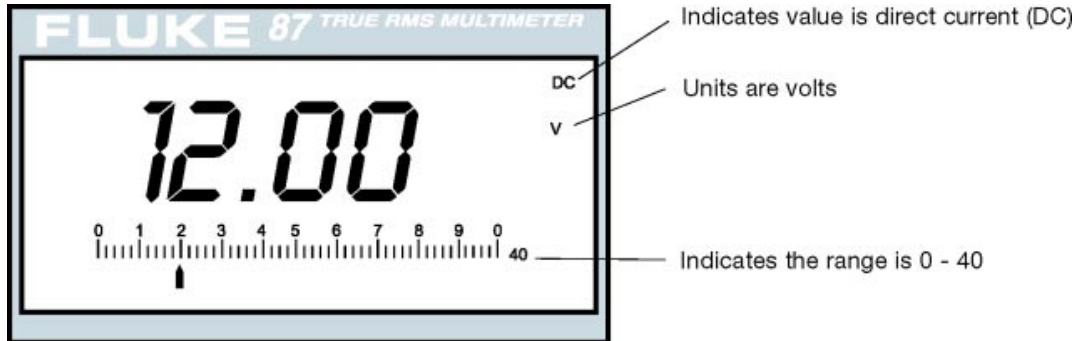

Fig. 1-06
TL623f106

Voltage type - The DMM shows the voltage type (AC or DC) in the upper right hand corner of the display.

Measured value - The large digits in the center of the display represent the measured value. Typically, the total value will contain four or five digits with a decimal point.

Units - To the right of the measured value number, the display shows letters that represent units:

- V volts
- A amperes
- Ω ohms

Range - The DMM displays the measurement range in the lower right hand corner of the display, just to the right of the bar graph.

Unit modifiers - The letters m, k, μ , and M modify unit values:

Volts -

mV	millivolts	volts x 0.001
kV	kilovolts	volts x 1,000

Amperes -

mA	milliamps	amps x 0.001
μ A	microamps	amps x 0.000001

NOTE Automotive technicians rarely use readings at the microamp level.

Ohms -

Ω	ohms	
k Ω	kilo-ohms	ohms x 1,000
M Ω	megohms	ohms x 1,000,000

DMM Over-Limit Display

The "O.L." or "over-limit" display appears whenever the test produces a value that exceeds the selected range. For resistance, that typically indicates an open circuit.

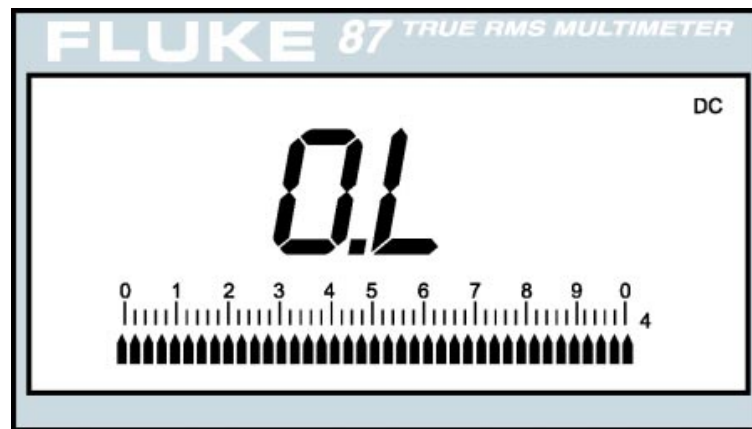

Fig. 1-07
TL623f107

Over-Limit Measurement - Most DMMs display an over-limit sign when the meter is measuring voltage or current that exceeds the selected or available range.

DMM Auto-Ranging Many DMMs offer a feature called “auto-ranging.” Meters with this feature allow you to disable it when you want to select ranges manually. When the meter is set to auto-range, it automatically selects the range most appropriate for the measurement being performed.

EXAMPLE Auto-ranging is convenient for making most measurements. It is especially helpful when you do not know what value to expect. A resistance measurement provides a good example.

A typical DMM has these ranges available for resistance measurements:

- 400 Ω
- 4 k./40 k Ω /400 k Ω
- 4 M./40 M Ω

If the DMM is connected to a component with an internal resistance of about 700 ohms, the meter can automatically select the 4 k. range. Without auto-ranging, you might scan through several ranges before determining that the 4 k Ω range is most appropriate for this measurement.

DMM Auto-Ranging

Digital multimeters with auto-ranging will automatically select the appropriate scale for a test measurement.

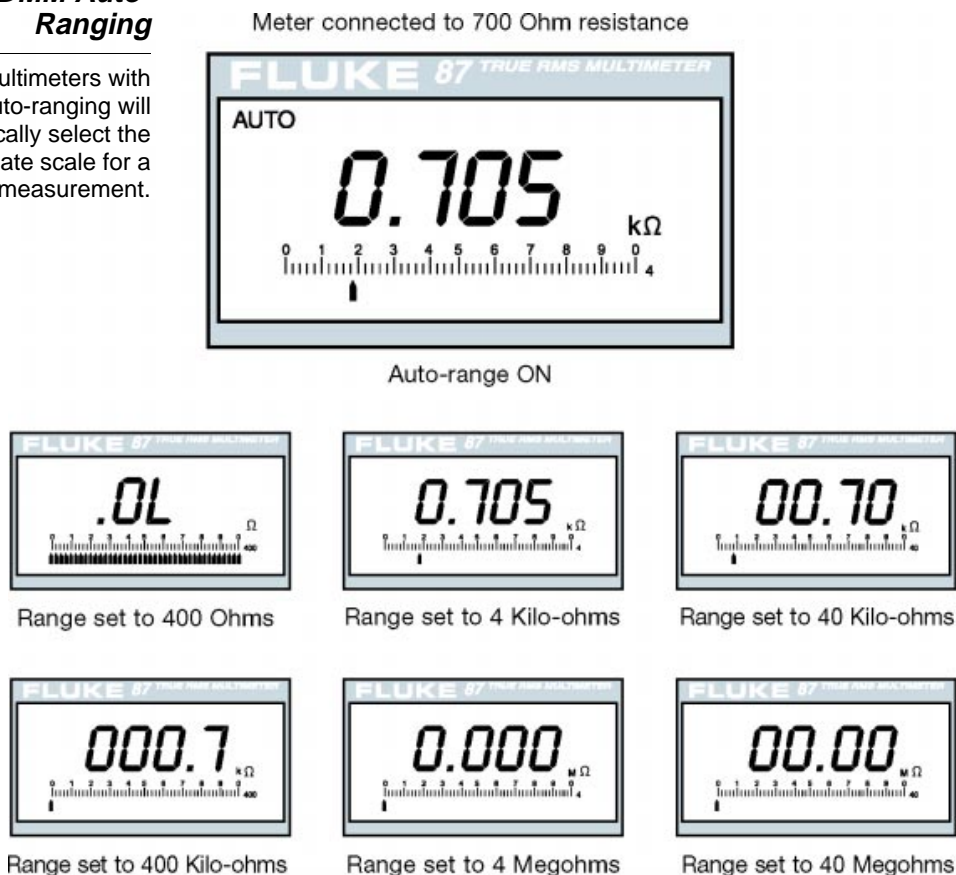

Fig. 1-08
TL623f108

DMM Test Leads and Input Jacks

The typical DMM has two test leads and four input jacks. The leads plug in as follows:

- BLACK - always plugs into the COM input jack.
- RED - plugs into one of the three remaining jacks, depending on what measurement is being performed.
 - V/ Ω /diode input for measuring resistance, conductance, and capacitance, as well as checking diodes (Voltage).
 - A input for measuring current up to 10 amps.
 - μ A/mA input for measuring current up to 400mA.

DMM Input Jacks

The meter leads must be plugged into the proper input jack for different tests (voltage and resistance or two ranges of current).

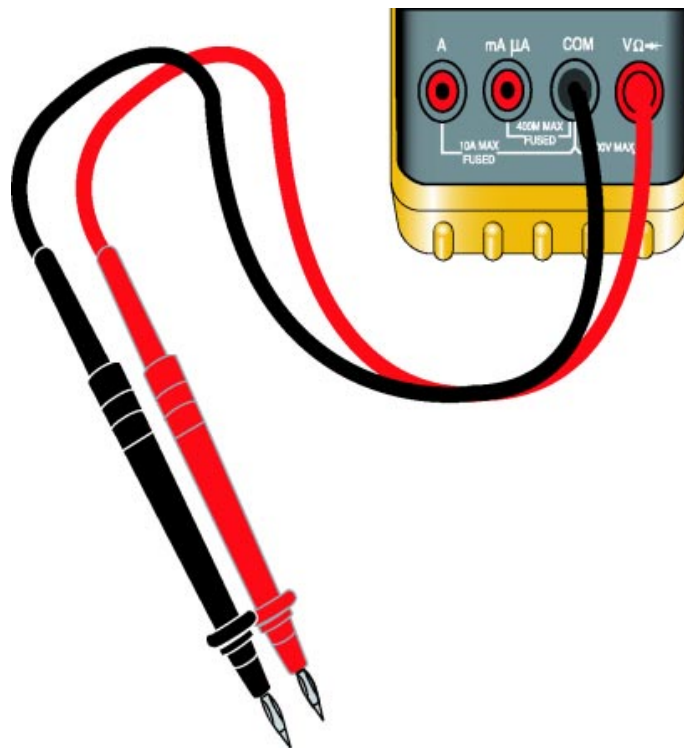

Fig. 1-09
TL623f109c

Voltage Voltage is the electromotive force between two points in a circuit.

EXAMPLE When you place the probes of a DMM on the terminals of a battery, you are measuring the electromotive force, or voltage, between the positive and negative battery plates.

Overview

This meter is connected to measure battery voltage.

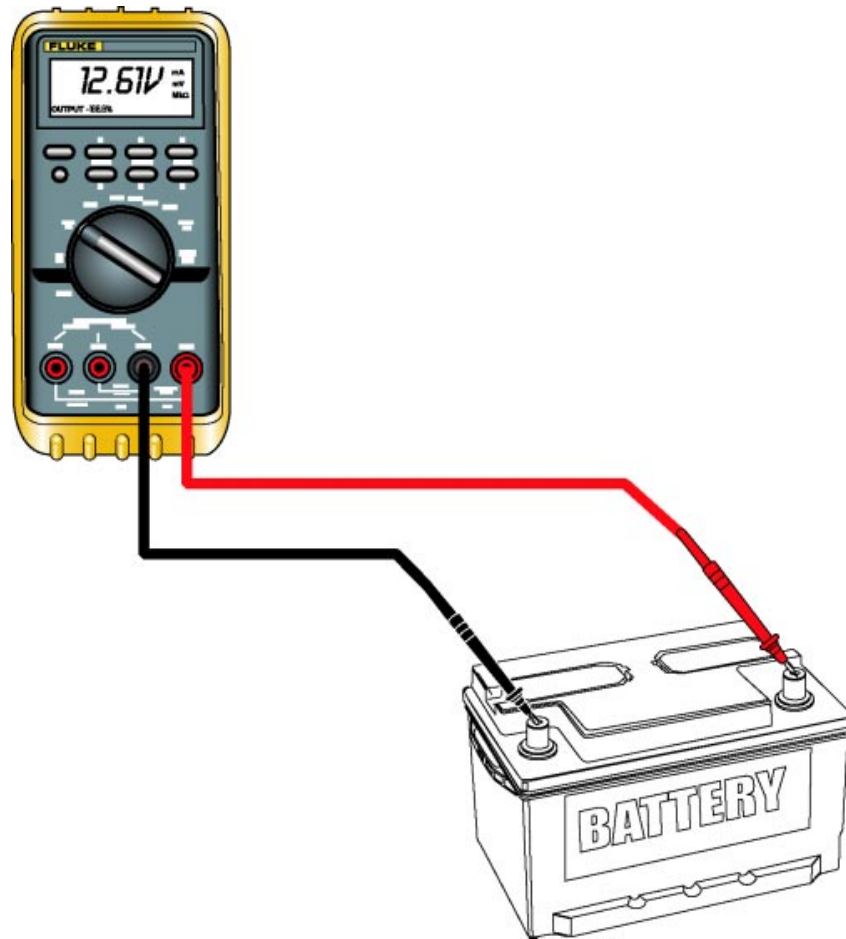

Fig. 1-10
TL623f110c

Applications of voltage - Technicians are concerned with voltage in different applications:

- Source voltage
- Available voltage
- Voltage drop

Source voltage - the battery supplies source voltage in most automotive electrical systems.

Measuring voltage - use the DMM to measure voltage. Note that voltage measurements are made by placing the voltage leads in a parallel circuit to the circuit you are testing. (Parallel circuits are covered in Section 2.)

Available voltage - is the voltage in a circuit available to operate the load.

Voltage drop - most parts of an electrical circuit offers some resistance to current. Every element that has resistance causes a voltage drop. Voltage drop increases as resistance increases.

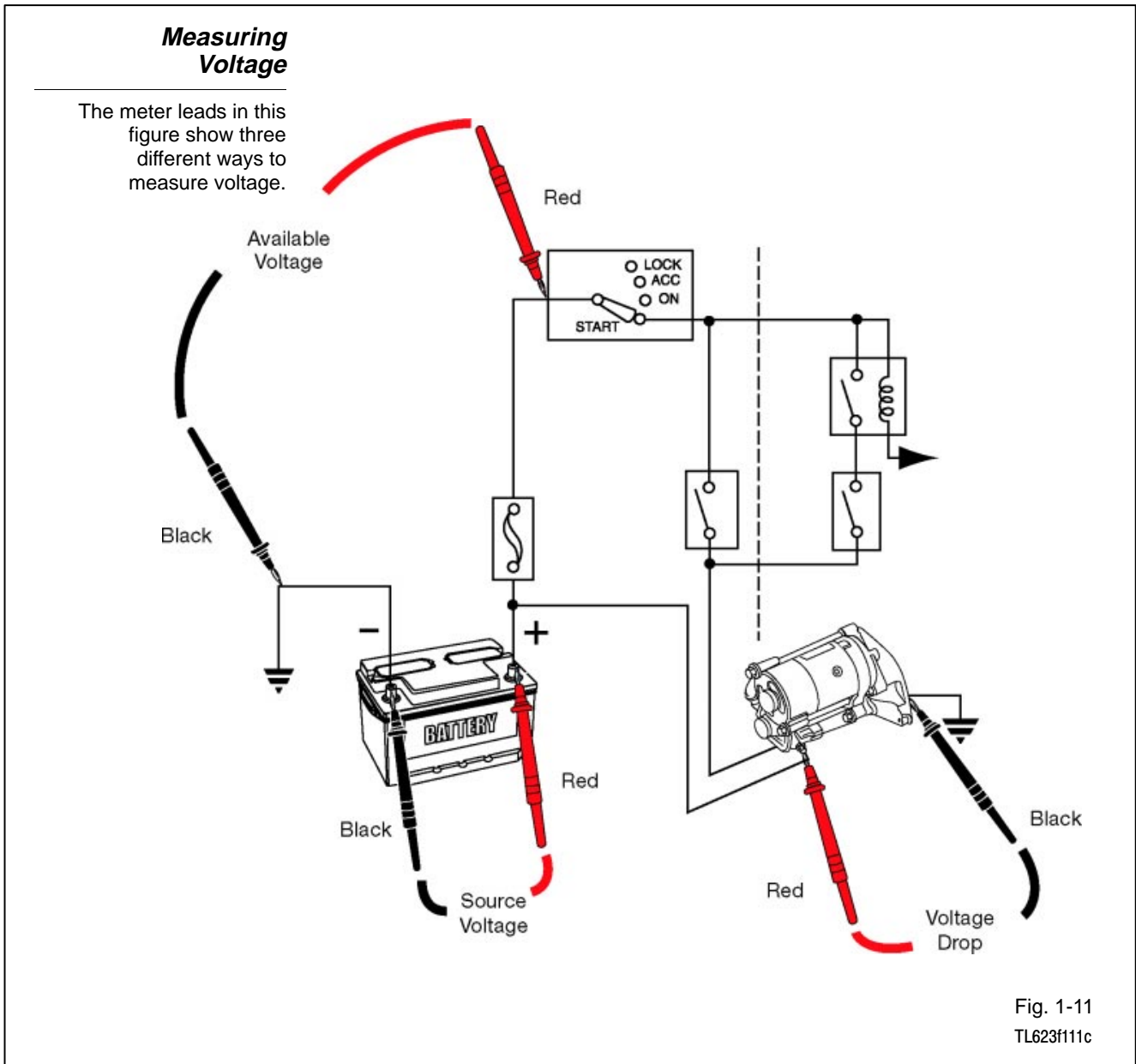

You can measure voltage ...

- Between any two points in a circuit
- Between any point in a circuit and ground
- Across any component in the circuit
 - Switches
 - Relay contacts and coils
 - Connectors
 - Wires
 - Cables

Available Voltage

The meter probes are placed to test the available voltage at the switch.

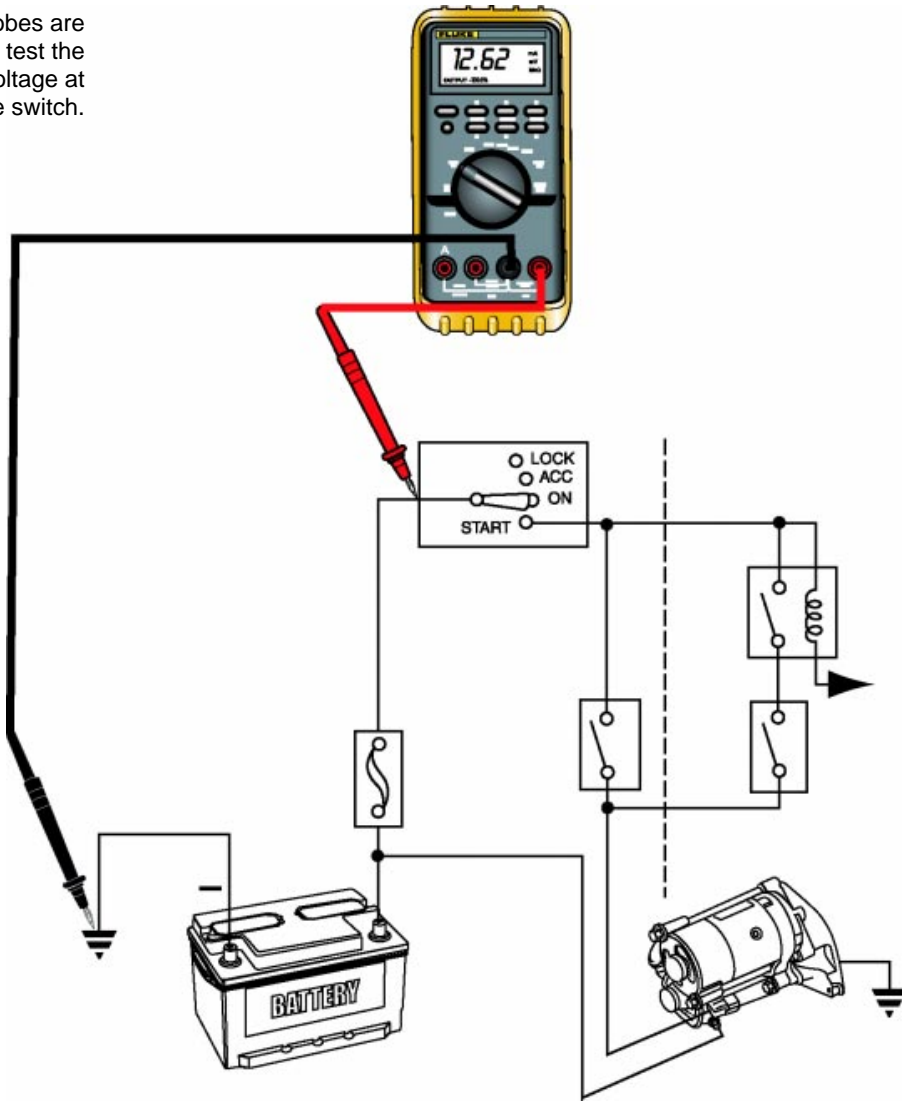

Fig. 1-12
TL623f112c

- Available Voltage** Measure available voltage using a digital multimeter with these steps:
1. Set the mode selector switch to Volts DC.
 2. Select the Auto-Range function or manually set the range.
 - Because the battery supplies available voltage in automotive circuits, you will typically measure voltages between zero and 12 to 14 volts.
 - For Fluke Series 80 DMMs, set the range to 40.
 - For other DMMs, set the range to the value closest to and higher than 12 volts.
 3. Connect the voltmeter leads in parallel with the circuit element to be tested.
 - Red lead closest to the battery (connect first).
 - Black lead to a good ground.
 4. Read measurement on DMM display.
 - Note polarity.
 - Correctly apply units.

NOTE

The meter leads are most likely reversed if the DMM display indicates negative polarity. It could also mean there is a fault in the circuit.

Voltage Drop

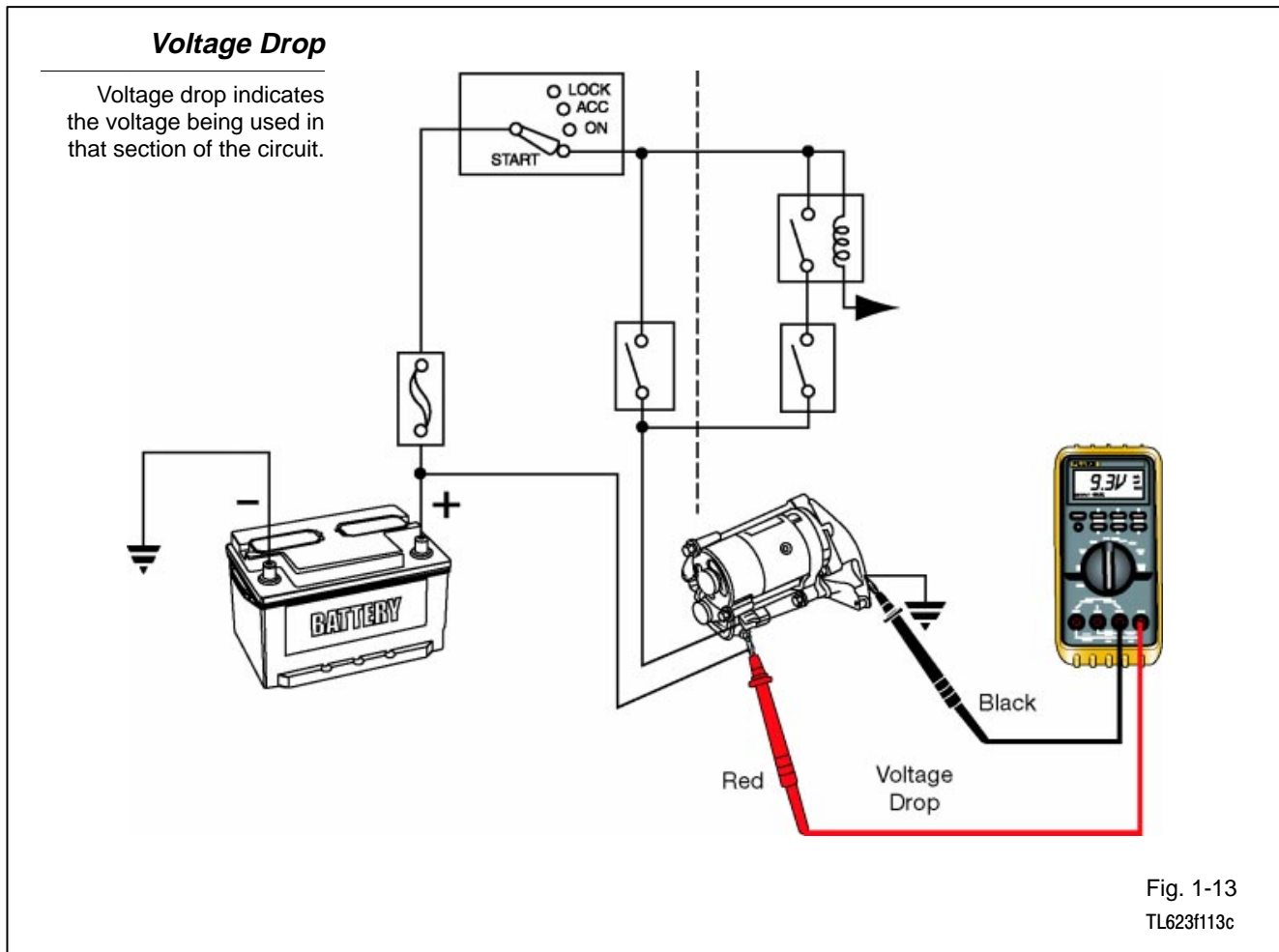

Voltage drop is one of the most useful tests you can perform. A voltage drop test isolates voltage used in the portion of the circuit being tested. A voltage drop test is done as follows:

1. Place the positive lead in the most positive section of the circuit you are testing.
2. Place the ground lead on the most negative section of the circuit you are testing.
3. Operate the circuit with the meter leads in place and note the reading.

Typical voltage drops are as follows:

- Across a switch, relay contacts or connector: Less than 200 mV (< 0.2 V).
- Across a section of the harness: Less than 200 mV (< 0.2 V).
- Across the load: Approximately source voltage (> 12.4 V).

The sum of all voltage drops in a circuit equals the source voltage. A voltage drop that exceeds normal limits indicates excessive resistance (an unwanted load) in that portion of the circuit.

A voltage drop test can quickly isolate excessive resistance in a circuit that may not be detected using a resistance test. The Ohmmeter only passes a small current through the portion of the circuit you are testing. A voltage drop test is done with circuit operating at normal current levels. A loose pin in a connector or a damaged wire may show continuity with the Ohmmeter but under load show a voltage drop due to the increased resistance during normal current levels.

Converting Voltage Values

To convert volts to millivolts (and vice versa) just move the decimal point three places.

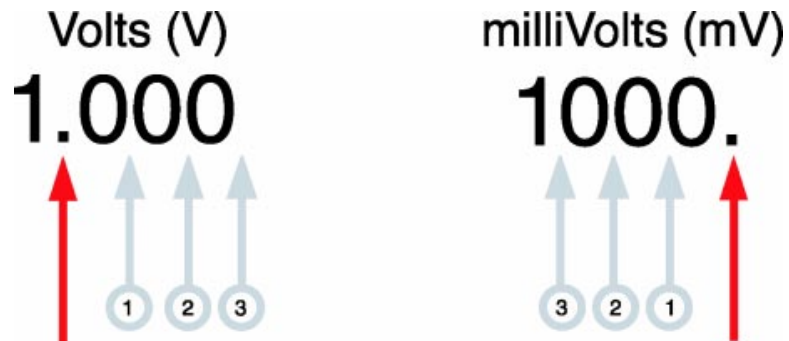

Fig. 1-14
TL623f114c

Converting Voltage Values - Automotive voltage values vary from around 14 volts to very small values under 50 mV.

CAUTION

Hybrid vehicles such as the Prius use circuits with high voltage and current (over 100 volts). Follow all safety precautions and service procedures when working on high voltage circuits.

Values under 1 volt are often expressed as millivolts. 1 volt is equal to 1,000 millivolts.

Convert the values as follows:

- Volts to millivolts, move the decimal point 3 places to the right.
(example: 1.34 V = 1,340 mV)
- millivolts to volts, move the decimal point 3 places to the left.
(example: 289 mV = .289 V)

Practice - Convert the following voltage values:

$$50 \text{ mV} = \underline{\hspace{2cm}} \text{ V}$$

$$3,233 \text{ mV} = \underline{\hspace{2cm}} \text{ V}$$

$$9.48 \text{ V} = \underline{\hspace{2cm}} \text{ mV}$$

$$.27 \text{ V} = \underline{\hspace{2cm}} \text{ mV}$$

Current Current is measured in amperes or “amps.” Current is sometimes called *amperage*.

Current is present in a circuit when ...

- There is sufficient available voltage.
- There is a continuous path from the source, through the load, to ground.

You will not use current measurements as often as voltage measurements. Most diagnostic specifications for automotive circuits specify voltage or resistance.

You will measure current to diagnose ...

- Faults in starting and charging systems.
- Parasitic load faults.

A parasitic load is an unwanted load that draws current when the ignition switch is turned to OFF. This problem is typically reported as “battery drains while vehicle is parked overnight.”

Measuring Current

A convenient place to measure current is at the fuse holder. When you remove the fuse to measure current, always use a fused jumper wire or leads as shown.

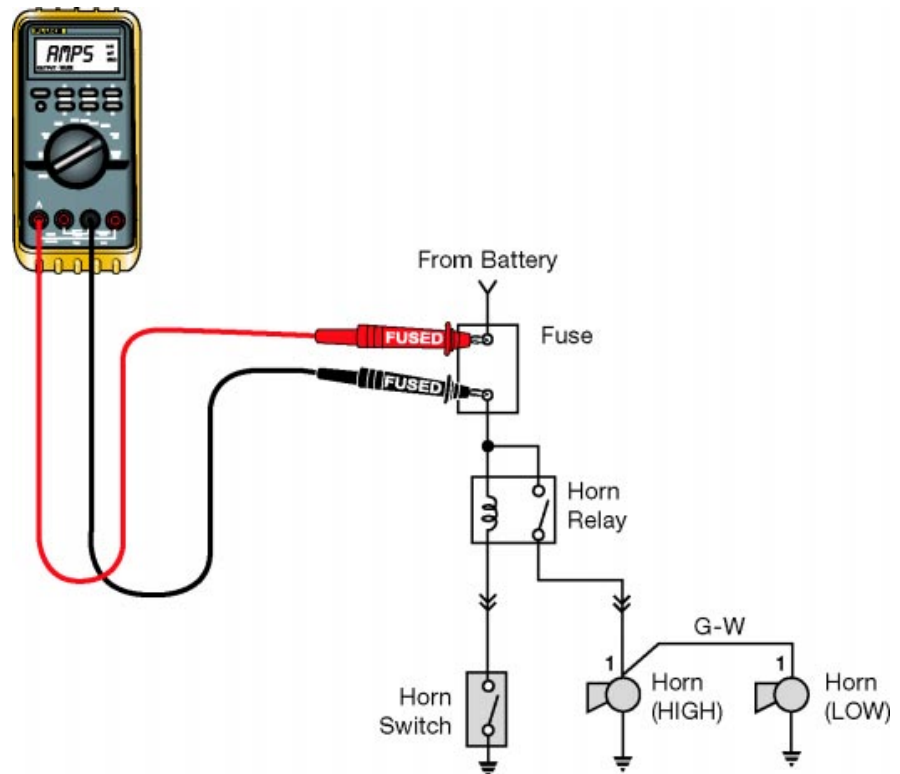

Fig. 1-15
TL623f115c

DMM connections - A DMM is connected differently for measuring current than it is for measuring voltage:

- Voltage - meter connected in parallel with circuit element.
- Current - meter connected in series with circuit (current actually flows through the meter).

Maximum current capacity - It is important to observe the maximum current capacity of the DMM you are using. To determine the maximum current capacity:

- Read the rating printed next to the DMM input jacks.
- Check the rating of the meter's fuse (maximum current capacity is typically the same as the fuse rating).

NOTE

Use only fuses of the correct type and rating for each meter. Substituting an incorrect fuse could cause damage to the meter.

If you suspect that a measurement will have a current higher than the meter's maximum rating, use an optional inductive pickup. Some specific testers, such as the Sun VAT series, have built in ammeters with high current ratings for testing starting and charging systems.

Measure current with a DMM using these steps:

1. Turn the circuit to be tested off.
 - Make sure leads are in correct jacks on DMM.
2. Set the DMM mode selector to the appropriate current function (typically amps or milliamps).
3. Select the Auto-range function or manually select the range for the expected current value.
4. Open the circuit at a point where the meter can be inserted in series.
 - A fuse holder makes a convenient point to open a circuit.
 - Use a jumper wire (with a fuse of the same rating in the circuit) to connect one of the meter leads.
5. Turn the circuit to be tested on.
6. Note the measured value on the DMM display.
 - Apply the correct units.
 - Convert units as needed to match diagnostic specifications.

Converting Current Values

To convert amperes to milliamps (and vice versa) just move the decimal point three places.

Amperes

1.000

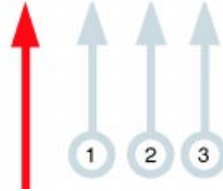

milliAmps

1000.

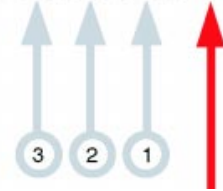

Fig. 1-16

TL623f116c

NOTE

Make sure that current values are expressed in the same units when comparing measured current values to diagnostic specifications.

Current should match the specifications in the service information.

- If current is too high, check for a short circuit or a faulty component.
- If current is too low, check for excessive resistance (with resistance and voltage drop measurements).

Converting amperage values - Automotive system currents vary from large to small:

- Large currents (up to 100 A) - charging and starting system.
- Small currents (less than an amp) - electronic control circuits.

Large current values typically display in amperes. Smaller current values may be expressed as milliamps. To convert from one to the other, simply move the decimal point three places:

- Amperes to milliamps - decimal point moves 3 places to the right.

$$1.000 \text{ ampere} = 1,000 \text{ milliamps}$$

- Milliamps to amperes - decimal point moves 3 places to the left.

$$0.001 \text{ ampere} = 1.000 \text{ milliamp}$$

Practice - Convert the following amperage values:

$$90 \text{ mA} = \underline{\hspace{2cm}} \text{ A}$$

$$9,416 \text{ mA} = \underline{\hspace{2cm}} \text{ A}$$

$$6.30 \text{ A} = \underline{\hspace{2cm}} \text{ mA}$$

$$.78 \text{ A} = \underline{\hspace{2cm}} \text{ mA}$$

Inductive current probes - These are also called “current clamps.” They are ...

- An optional accessory for DMMs.
- Convenient (no need to open the circuit being tested).
- Safe.

Current probes work by sensing the magnetic field generated in a wire by the current.

NOTE

The following procedure applies to most Fluke DMMs and current probes. Some meters may operate differently. Check the operator’s manual for your equipment to confirm.

Measure current with a clamp-on current probe using these steps:

1. Set DMM mode selector to millivolts (mV).
2. Connect probe to meter.
3. Turn probe on.
4. Use the zero adjust knob (if equipped) to zero the DMM display (with jaws empty).
5. Clamp probe around wire in circuit to be tested.
6. Orient the arrow on the clamp in the proper direction (in the direction of current flow).
7. Note the voltage reading on the DMM display.
8. Convert the voltage reading to amperes (1 mV = 1 ampere).

EXAMPLE If the reading is 1 mV (millivolt), then the current is 1 ampere. If the reading is 15 mV, then the current is 15 amperes.

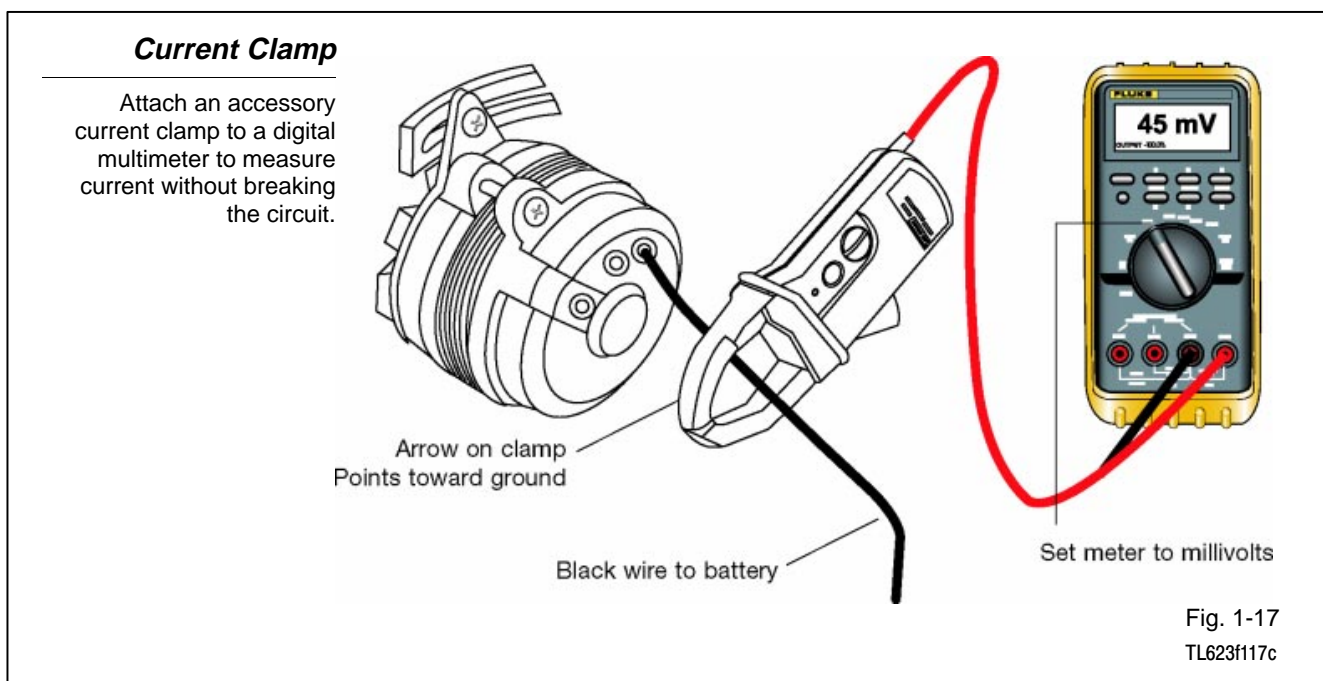

Resistance **Circuit load** - The load has the highest resistance in a typical circuit. Other circuit elements may be used to control current by providing additional resistance.

EXAMPLES Resistance used to control current:

- Instrument panel lighting controlled by dimmer switch.
- Blower speed controlled by blower motor resistors.

Excessive resistance - Excessive resistance in a circuit can prevent it from operating normally. Loose, damaged, or dirty connections are a common source of excessive resistance.

Resistance

To get accurate resistance measurements, isolate the circuit or component and make sure it is not connected to a power source.

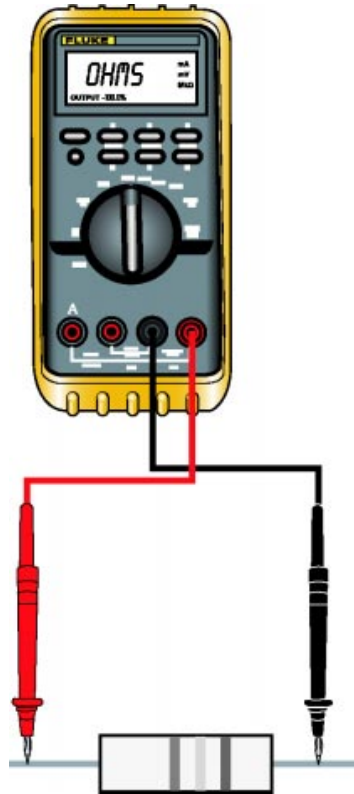

Fig. 1-18
TL623f118c

Measure resistance with a DMM using the following steps:

1. Make sure the circuit or component to be tested is isolated and not connected to any power source.

CAUTION

Some meters may be damaged if you apply voltage to the meter leads when the mode selector is set to measure resistance.

2. Set the DMM mode selector to measure resistance.
3. Select the Auto-range feature or manually select a range appropriate for the test.
4. Confirm the meter calibration by touching the meter's two probes together.
 - For a typical DMM, resistance of the leads should be 0.2 ohms or less.
5. Connect the meter leads across the component or circuit segment to be tested.
6. Read the measured value on the DMM display.
 - Note the units.

Other Ohmmeter Functions - The ohmmeter function of a DMM can also be used for other tests and measurements:

- Circuit continuity (with audible beep to confirm continuity)
- Conductance (very high resistance)
- Diode test (some DMM's cannot test)
- Capacitance (some DMM's cannot test)

Circuit continuity tests verify a path for current exists. The DMM may beep to indicate continuity and display a very low ohm reading. An open circuit is indicated by a very high reading or OL (out of limits - infinite resistance).

Measuring Resistance

This meter is connected to measure the resistance across the switch. Notice the fuse and relay have been removed to isolate the component being tested.

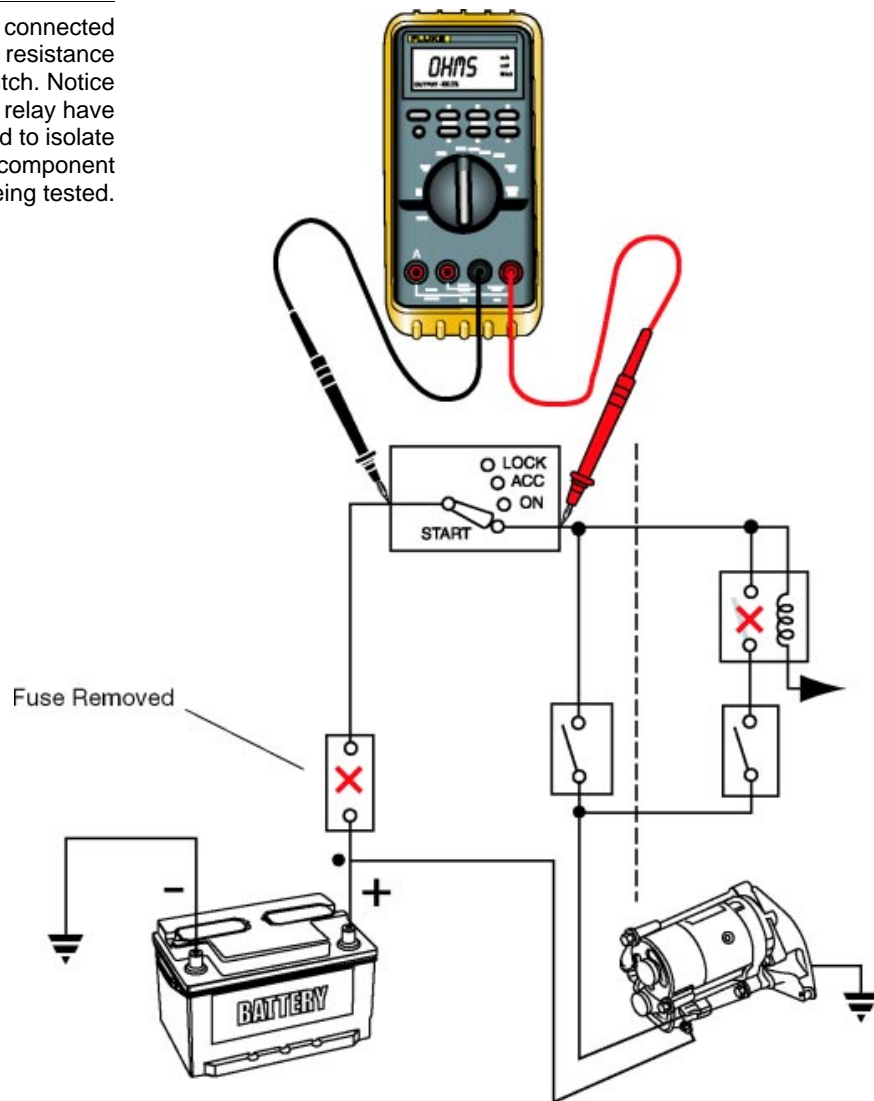
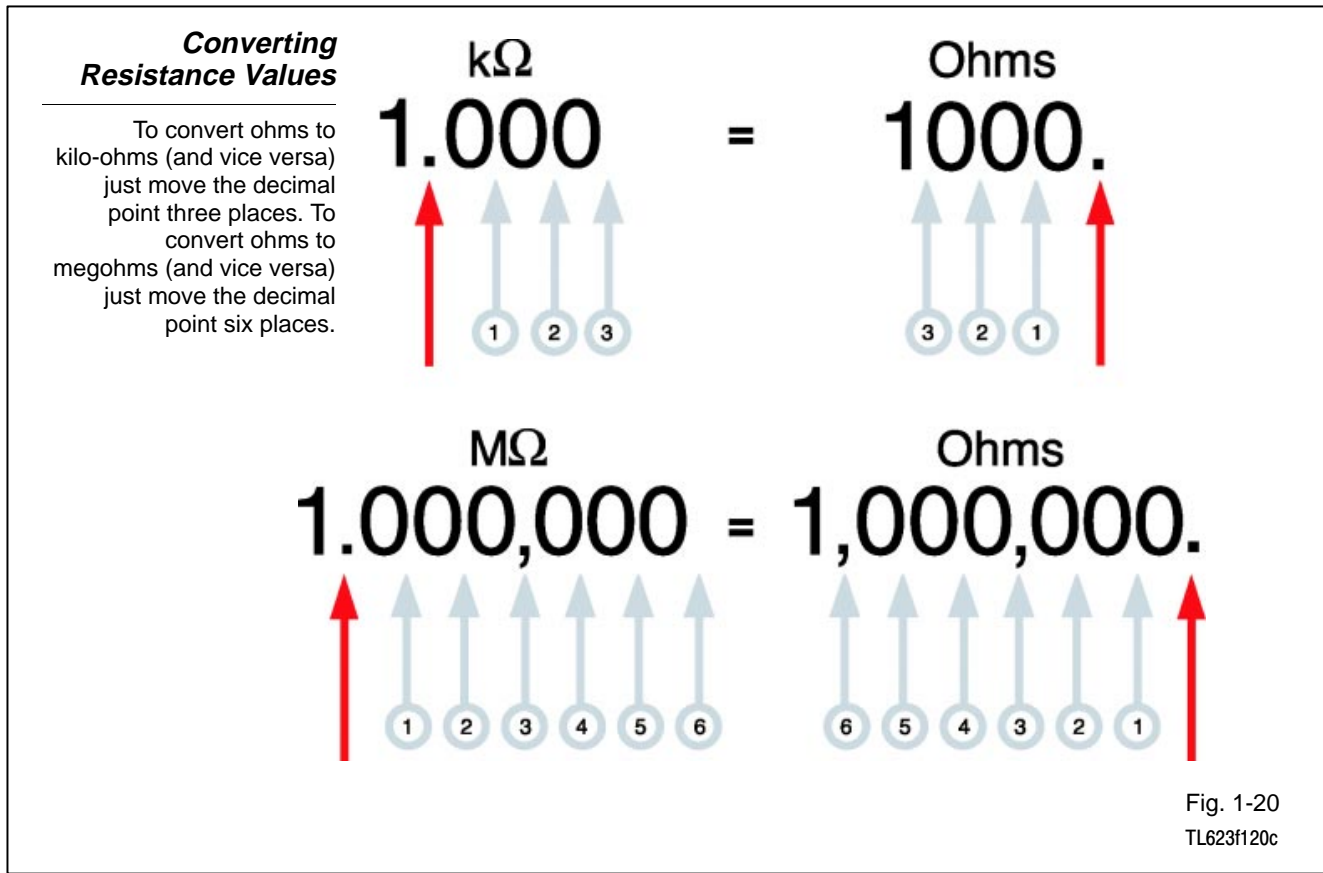

Fig. 1-19
TL623f119c

NOTE Make sure that resistance values are expressed in the same units when comparing measured resistance values to diagnostic specifications.

Resistance should match the specifications in the service information.

- If resistance is too high, check for an open circuit or a faulty component.
- If resistance is too low, check for a short circuit or faulty component.



Converting resistance values - Automotive system resistance values vary from large to small.

Low resistance levels are expressed in ohms. Large resistance values are expressed in kilo-ohms and very large values are expressed in megohms.

- 1 kilo-ohm = 1,000 ohms (1.0 kΩ)
- 1 megohm = 1,000,000 ohms (1.0 MΩ)

Convert ohm readings as follows:

- kilo-ohms to ohms - decimal point moves 3 places to the right.
- ohms to kilo-ohms - decimal point moves 3 places to the left.
- Megohms to ohms - decimal point moves 6 places to the right.
- Ohms to Megohms - decimal point moves 6 places to the left.

Practice - Convert the following resistance values:

$$2,458 \Omega = \text{_____ k}\Omega$$

$$.896 \text{ k}\Omega = \text{_____ } \Omega$$

$$5.87 \text{ M}\Omega = \text{_____ } \Omega$$

$$3,234,000 \Omega = \text{_____ M}\Omega$$

Common Mistakes

This figure shows similar looking (but very different) values that can easily be mistaken when reading the display.



Display showing over-limit

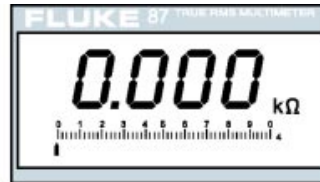

Display showing zero



Display showing 10 Ohms

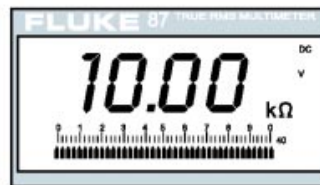

Display showing 10 Kilo-ohms

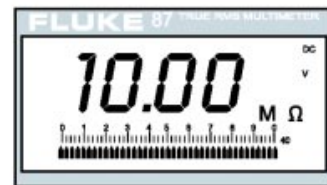

Display showing 10 Megohms

Fig. 1-21
TL623f121

Common mistakes in resistance measuring - There are some common mistakes a technician can make when doing resistance measurements. You can save yourself time and aggravation by avoiding these simple errors:

- Mistaking ZERO OHMS and O.L for over-limit - Take care to note whether the display is showing zero ohms (no resistance) or O.L (resistance higher than selected range or capacity of meter).
- Using the wrong UNITS OF MEASURE - Look for the modifying units on the DMM display. There is a big difference between 10 ohms, 10 kilo-ohms (kΩ), and 10 megohms (MΩ).
- Confusing DECIMAL POINT POSITION - Look for the position of the decimal point. It is important when dealing with large numbers.

Diode Check

To check a diode, use the Diode Check function on the meter and apply both forward and reverse bias.

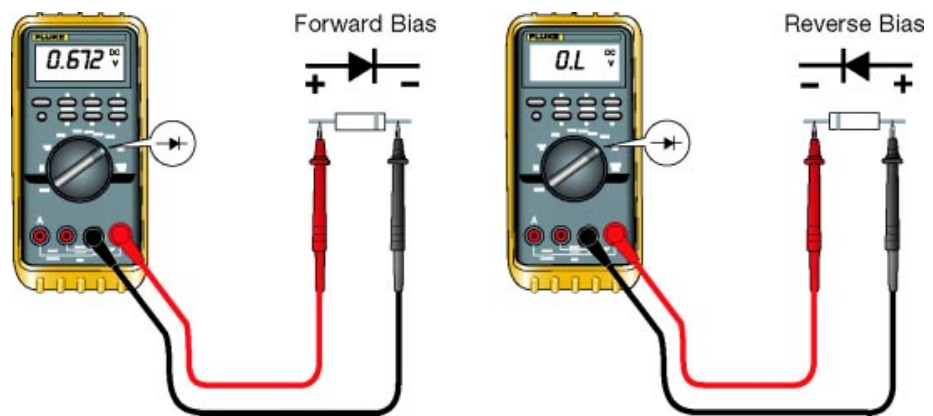

Fig. 1-22
TL623f122c

Diode Check - A diode is like an electronic valve. It allows current to flow in one direction but not in the other.

- The diode conducts current in a circuit when a small voltage is applied in the correct polarity (direction).

Use the diode check function to test a diode with the following steps:

1. Set the DMM mode selector to diode check.
2. Connect the red lead to the anode (the end away from the stripe on the diode).
3. Connect the black test lead to the cathode (end closest to the stripe).
4. Read the DMM display.
 - Forward bias voltage for most diodes in automotive applications is about 0.5 and 0.8 volts.
5. Reverse the test leads to test the diode in reverse bias.
6. The DMM display should show O.L for “over-limit.”

Power

Power is typically calculated, not measured.

Sample Calculation for Power Consumption of Load X:

- Voltage drop across Load X = 12 V
- Current through Load X = 200 mA
- Convert 200 mA to amps (0.2 A)
- Voltage x Current = Power
12 V x 0.2 A = 2.4 Watts

Fig. 1-23

Power **Definition of power** - Power is the amount of work being done by the load in a circuit. Light bulbs are typically rated by voltage and watts.

Equation for power - Power is typically calculated rather than measured. This is the equation for calculating power:

$$\text{Voltage} \times \text{Current} = \text{Power}$$

Units for power calculations

- Voltage - volts
- Current - amps
- Power - watts

EXAMPLE This example shows the power consumption of Load X:

- Voltage drop across Load X = 12 V
- Current through Load X = 200 mA
- Convert 200mA to amps (0.2 A)
- Voltage x Current = Power
12 V x 0.2 A = 2.4 Watts



Notes



WORKSHEET 1-1
Using a Digital Multimeter: Voltage Measurement

Worksheet Objectives

In this worksheet, you will work with the type of digital multimeter typically used by automotive technicians. When you have completed this worksheet, you will be able to use a DMM to make voltage measurements.

Tools and Equipment

For this exercise you will need the following:

- Electrical simulator
- Digital multimeter

Exercise 1: Measuring Voltage

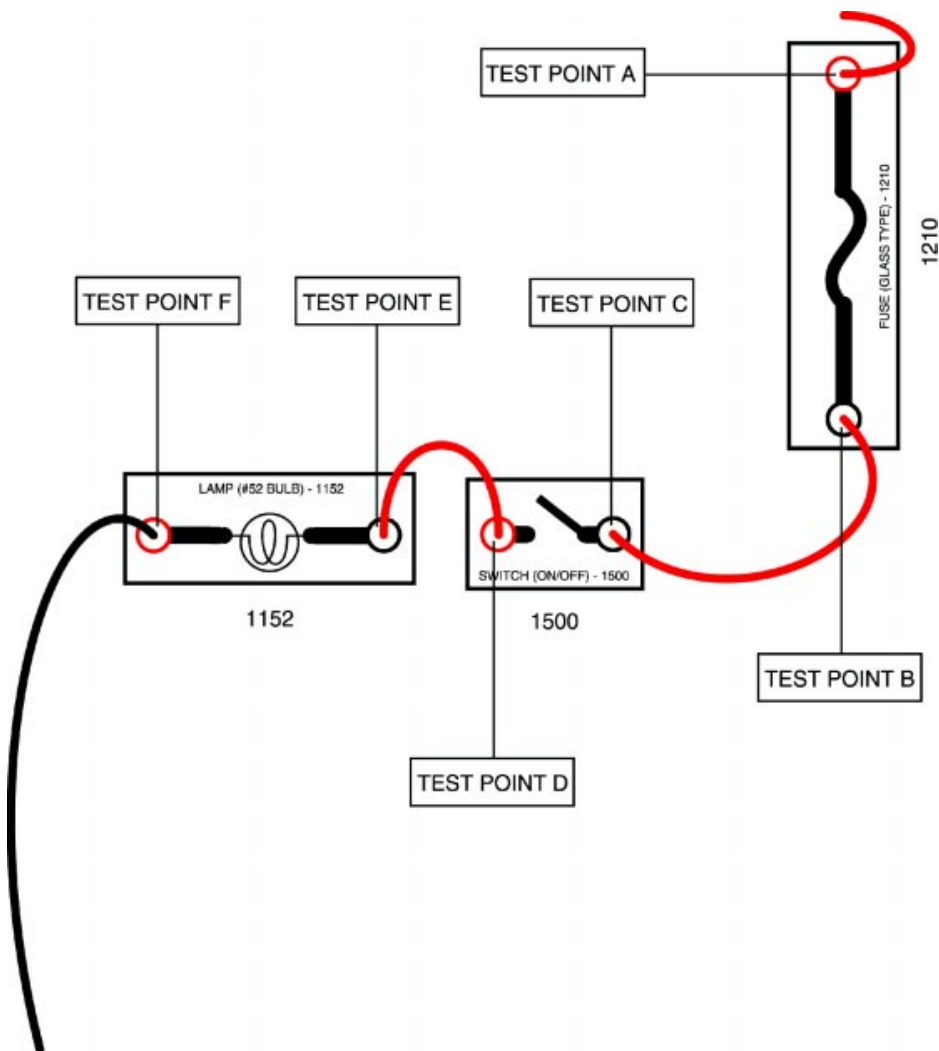

Fig. 1W1-1
 TL623f001c-1W1

1. Build the circuit shown above on the electrical simulator.
2. Set up your DMM to measure the voltage in this circuit:
 - Mode selector to DC Volts
 - Auto-range on
 - Black lead plugged into COM input jack
 - Red lead plugged into Volt/Ohm/Diode input jack
3. Turn on the electrical simulator power supply and close the switch (light bulb should come on).
4. Measure source voltage:
 - Place the red lead on the positive side of the voltage source (power supply).
 - Place the black lead on the ground (negative) side of the power source.
 - What is the source voltage? _____
5. Measure available voltage:
 - Keep the black lead touching the ground portion of the circuit.
 - Apply the red lead to each of the six test points.

Write the values in the blank spaces below.

TEST POINT A _____ volts

TEST POINT B _____ volts

TEST POINT C _____ volts

TEST POINT D _____ volts

TEST POINT E _____ volts

TEST POINT F _____ volts

Using a Digital Multimeter: Voltage Measurement

6. Measure voltage drop:

- Place the red lead on the most positive side of the circuit component being tested.
- Place the black lead on the most negative (closest to ground) side of the circuit component being tested.
- The circuit must be on in order to measure the voltage drops.
- Write the values for the voltage drops of the following components:
 - Jumper wire from source to fuse: _____
 - Fuse: _____
 - Jumper wire from fuse to switch: _____
 - Switch: _____
 - Jumper wire from switch to the lamp: _____
 - Lamp: _____
 - Jumper wire from lamp to ground: _____

7. Leave Circuit 1-1 on the electrical simulator for use in the next worksheet.

Voltage Measurement

Name: _____ Date: _____

Review this sheet as you are doing the Voltage Measurement worksheet. Check each category after viewing the instructor's presentation and completing the worksheet. Ask the instructor if you have questions regarding the topics provided below. Additional space is provided under topic for you to list any other concerns that you would like you instructor to address. The comments section is provided for your personal comments, information, questions, etc.

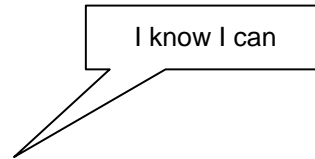
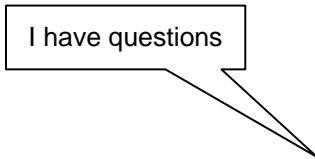

Topic	Comment		
Measure Source Voltage			
Measure Available Voltage			
Measure Voltage Drop			



WORKSHEET 1-2
Using a Digital Multimeter: Current Measurement

Worksheet Objectives

In this worksheet, you will practice making current measurements with a digital multimeter (DMM). When you have completed this worksheet, you will be able to use a DMM to make current measurements.

Tools and Equipment

For this exercise you will need the following:

- Electrical simulator
- Digital multimeter

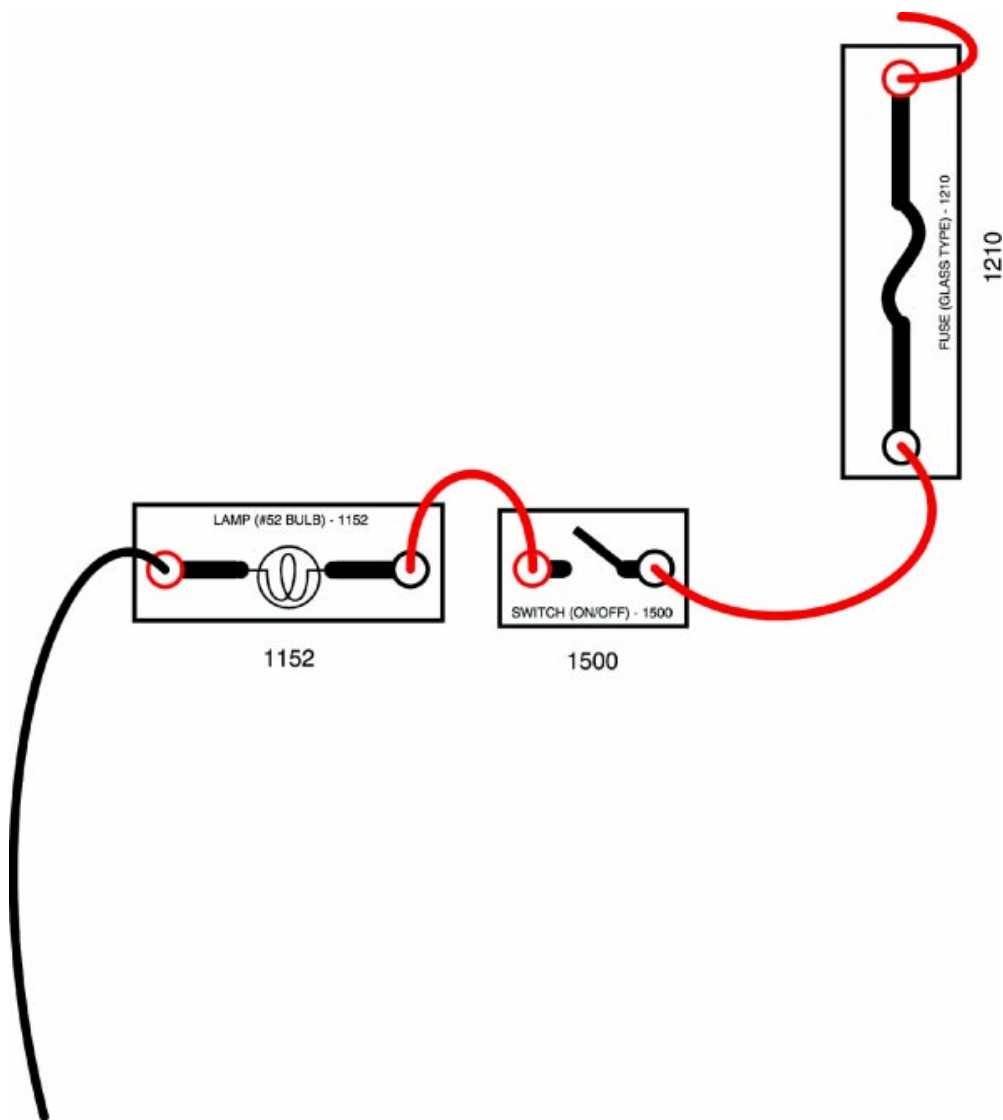

Fig. 1W2-1
 TL623f001c-1W2

Exercise 1: Measuring Current

1. Continue to use the circuit shown in Fig. 1W2-1.
2. Turn off the electrical simulator power supply.
3. Remove lead between the fuse and the switch.
4. Set up your DMM to measure the current in this circuit:
 - Mode selector to milliamps/Amps.
 - Auto-range on.
 - Red lead on Amp jack.
 - Black remains on COM jack.
 - Connect the red lead to terminal B of the fuse.
 - Connect the black lead to terminal C of the switch.
5. Turn on the electrical simulator power supply and close the switch.
6. Interpret the amperage value on the DMM display and write it here: _____ Amps.
7. Re-install lead between the fuse and the switch.
8. Leave Circuit 1-1 on the electrical simulator for use in the next worksheet.

Note: If the reading is less than 200mA, you can use the 200mA jack on the DMM for a more accurate reading.

Current Measurement

Name: _____ Date: _____

Review this sheet as you are doing the Current Measurement worksheet. Check each category after viewing the instructor's presentation and completing the worksheet. Ask the instructor if you have questions regarding the topics provided below. Additional space is provided under topic for you to list any other concerns that you would like you instructor to address. The comments section is provided for your personal comments, information, questions, etc.

I have questions

I know I can

Topic	Comment		
Measuring Current			



Notes



WORKSHEET 1-3
Using a Digital Multimeter: Resistance Measurement

Worksheet Objectives

In this worksheet, you will practice making resistance measurements with a digital multimeter (DMM). When you have completed this worksheet, you will be able to use a DMM to make resistance measurements.

Tools and Equipment

For this exercise you will need the following:

- Electrical simulator
- Digital multimeter

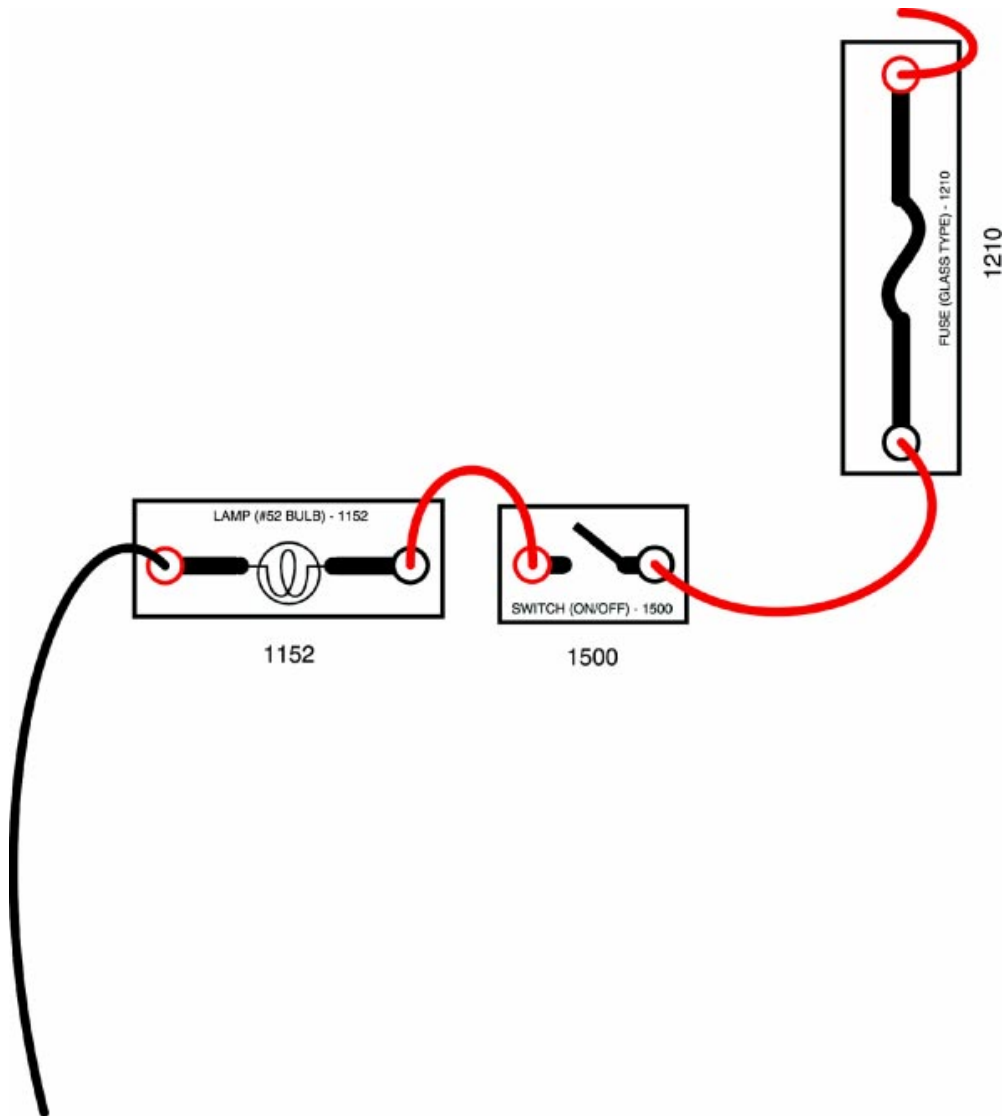

Fig. 1W3-1
 TL623f001c-1W2

Exercise 1: Measuring Resistance

1. Continue to use the circuit shown in Fig. 1W3-1.
2. Turn off the electrical simulator power supply and disconnect the positive and negative leads from it.
3. Set up your DMM to measure resistance in this circuit:
 - Mode selector to Ohms
 - Auto-range on
 - Leads in correct jacks on DMM (red in V Ω , black in com)
4. At each test point shown on the wiring diagram (see Fig. 1W3-1) connect the DMM test leads as follows:
 - Isolate each component by disconnecting the jumper wire linking to another component.
 - Red lead to most positive side at component.
 - Black lead to most negative side at component.
5. Note the resistance values on the DMM display and write them in the blank spaces below. Make sure to include any letters modifying the units of measure (k for kilo or M for mega).

Fuse _____ ohms

Switch _____ ohms

Lamp _____ ohms

Wire _____ ohms

Resistance Measurement

Name: _____ Date: _____

Review this sheet as you are doing the Resistance Measurement worksheet. Check each category after viewing the instructor's presentation and completing the worksheet. Ask the instructor if you have questions regarding the topics provided below. Additional space is provided under topic for you to list any other concerns that you would like your instructor to address. The comments section is provided for your personal comments, information, questions, etc.

I have questions

I know I can

Topic	Comment		
Measuring Resistance			



Notes



WORKSHEET 1-4

Using a Digital Multimeter: Diode Check

Worksheet Objectives

In this worksheet, you will practice using a digital multimeter (DMM) to check a diode. When you have completed this worksheet, you will be able to use a DMM to check diodes for proper operation.

Tools and Equipment

For this exercise you will need the following:

- Diode (PN 1350)
- Digital multimeter

Exercise 1: Checking a Diode

1. Obtain the diode from the electrical simulator kit (part number 1350).
2. Set up your DMM for diode check:
 - Mode selector to the diode symbol $\rightarrow|$
 - Auto-range on
 - Black test lead plugged into COM input jack
 - Red test lead plugged into Volts/Ohms/Diode input jack
3. Forward bias the diode:
 - Connect red test lead to the diode's anode (end away from the stripe)
 - Connect the black test lead to the cathode (end closest to the stripe)
4. Note the DMM display. Write the value here: _____ Volts
5. Reverse bias the diode:
 - Connect black test lead to the diode's anode
 - Connect the red test lead to the cathode
6. Note the DMM display. Write the value here: _____ Volts

Diode Check

Name: _____ Date: _____

Review this sheet as you are doing the Diode Check worksheet. Check each category after viewing the instructor's presentation and completing the worksheet. Ask the instructor if you have questions regarding the topics provided below. Additional space is provided under topic for you to list any other concerns that you would like your instructor to address. The comments section is provided for your personal comments, information, questions, etc.

I have questions

I know I can

Topic

Comment

Topic			Comment
Checking a Diode			

Section 2

Electrical Circuits

Types of Circuits A circuit is a complete path for current when voltage is applied. There are three basic types of circuits:

- Series
- Parallel
- Series-parallel

All circuits require the same basic components:

- Power source
- Protection device
- Conductors
- Load
- Control device
- Ground

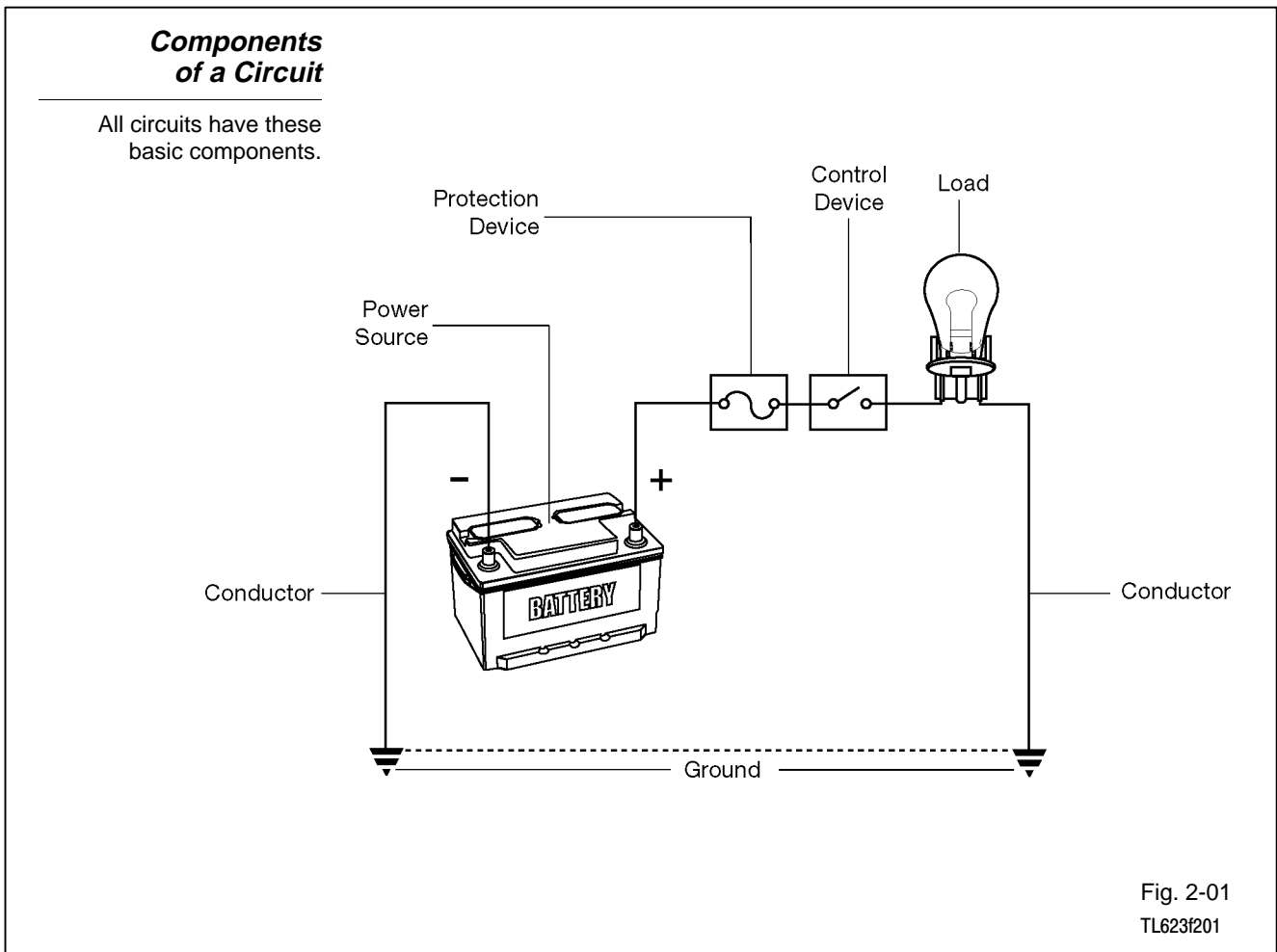

Power source - In automotive circuits, the source is typically the battery.

Protection device - Circuits require protection from excessive current. Excessive current generates heat and can damage wires, connectors, and components. Fuses, fusible links, and circuit breakers protect circuits by opening the circuit path when there is too much current.

Load - The load can be any component that uses electricity to do work:

- Light
- Coil
- Motor

Control device - The simplest control device is a switch. A switch opens or closes the path for current. Close the switch and current is present to operate the load. Open the switch and current stops. The load no longer operates.

A control device can do more than just turn the load on or off. It can also regulate how the load works by varying the amount of current in the circuit. A dimmer is an example of such a control device.

There are other types of control devices:

- Relays
- Transistors
- ECUs

Ground - The connection to ground provides a “shortcut” back to the source. Ground is typically any major metal part of a vehicle. You can think of ground as a zero voltage reference. Ground provides a common connection that all circuits can use so that they do not have to be wired all the way back to the battery.

The circuit type is determined by how the power source, protection devices, conductors, loads, control devices, and grounds are connected.

Simple Series Circuit

This diagram shows a simple series circuit. Battery voltage is applied through the fuse to the control device (switch). When the switch closes, there is current in a single path through the load (lamp) to ground.

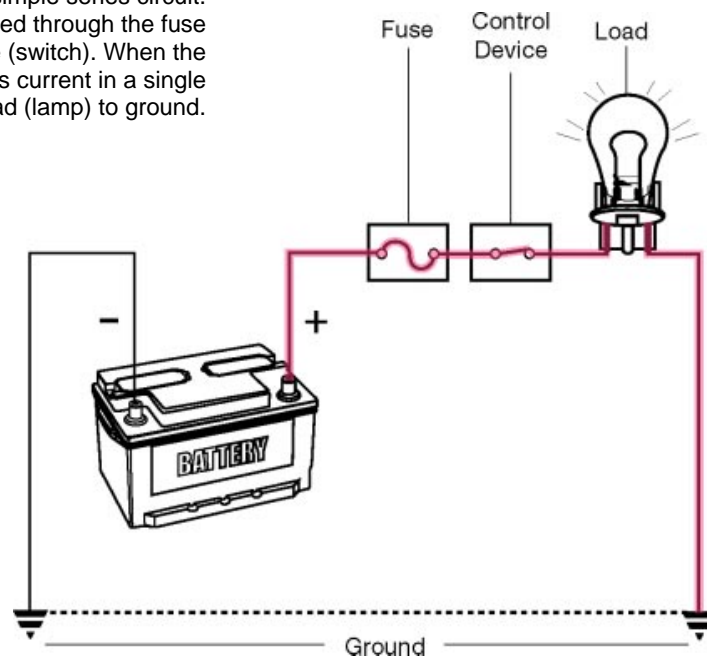

Fig. 2-02
TL623f202c

Key Features A series circuit has these key features:

- Current is the same in every part of the circuit.
- The sum of all the individual resistances equals the total resistance in the circuit.
- The sum of the individual voltage drops in the circuit equals the source voltage.

Series Circuits A series circuit has only one path for current. That means current is the same through every part of the circuit. If any part of the circuit is broken or disconnected, the whole circuit will stop working. No current is present in a series circuit unless there is continuity through the entire circuit.

Applying Ohm's Law You can use Ohm's Law to predict the behavior of electricity in a circuit.

For series circuits, apply Ohm's Law as follows:

- Total circuit resistance (R_T) equals the sum of the individual load resistances ($R_1 + R_2$).
 - $R_T = R_1 + R_2$
- Circuit current (I) equals voltage (E) divided by total resistance (R).
 - $I = E/R$
- Voltage drop (E_{R1} , E_{R2}) across each load equals current (I) times load resistance (R_1 , R_2).
 - $E_{R1} = I \times R_1$
 - $E_{R2} = I \times R_2$

NOTE In most modern texts, current is represented as "I" and voltage as "E." You may also see these represented as "A" for amperage, instead of "I" for current, and "V" instead of "E" for voltage. When using that terminology, the Ohm's Law equation looks like this: $A = V/R$.

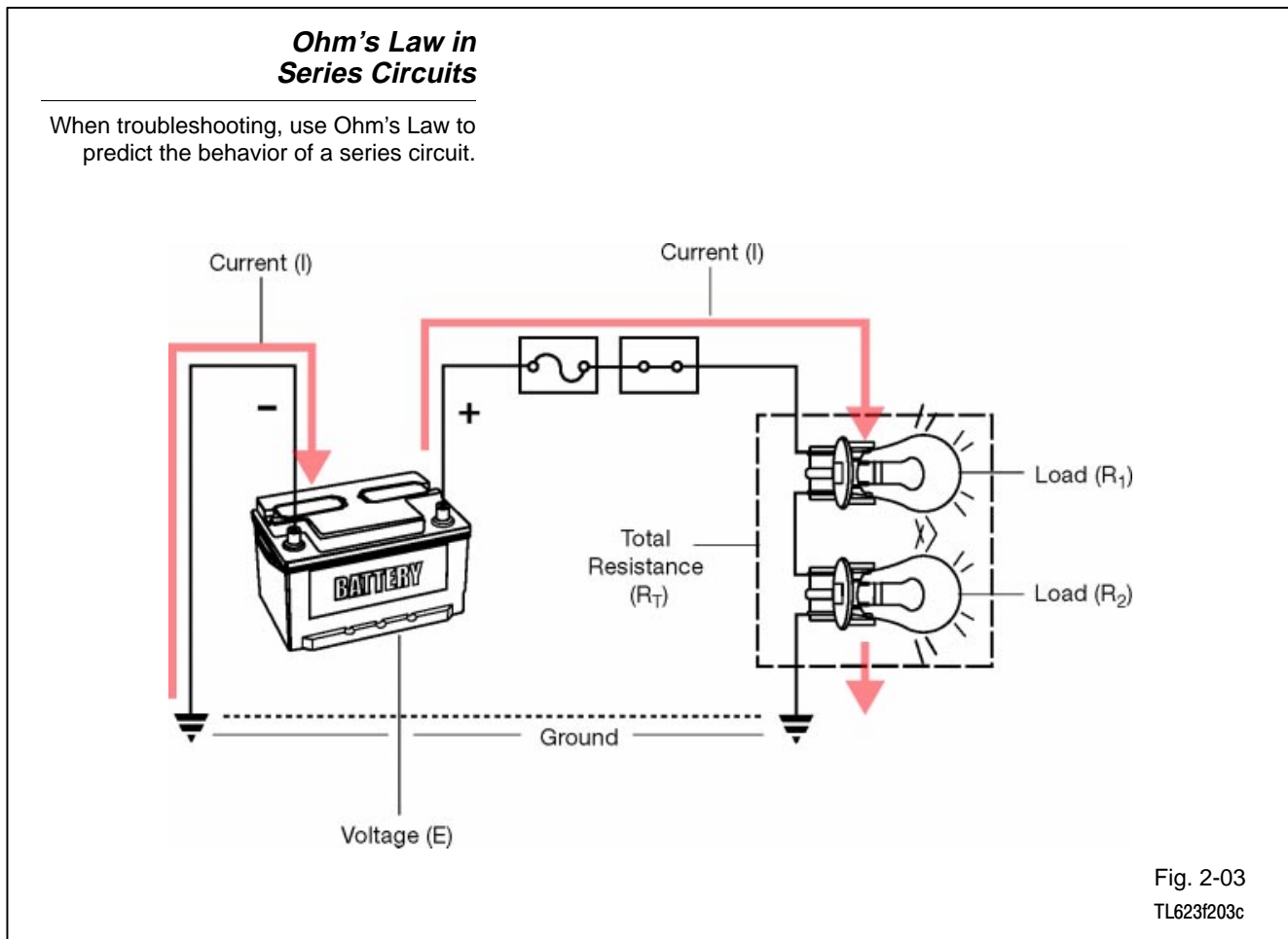

Use Ohm's Law to troubleshoot series circuits:

- Poor connections and faulty components can increase resistance.
- Since $E/R = I$, more resistance means less current.
- Less current affects the operation of the loads (dim lamps, slow running motors).
- There is no current if there is a break (open circuit) anywhere in the current path.
- Since $E/R = I$, lower voltage also means less current and higher voltage means more current.
- High voltage increases current and can also affect circuit operation (blown fuses, premature component failure).

Voltage Drops in a Series Circuit

Troubleshoot by taking voltage measurements with a digital multimeter.

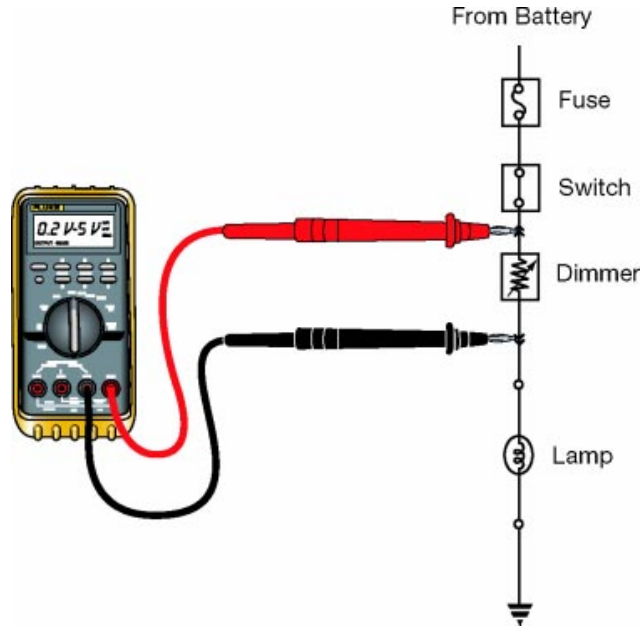

Fig. 2-04
TL623f204c

Voltage drops in a series circuit - Every element in a circuit that has resistance generates a voltage drop.

- The load in this circuit (lamp) generates the largest voltage drop.
- The dimmer generates a smaller, variable voltage drop to control the brightness of the lamp.
- Other components also generate even smaller voltage drops.
 - Fuse and fuse connectors
 - Wiring
 - Harness connectors
- The sum of all the voltage drops is equal to the source voltage.

Current in a Series Circuit

When practical, remove the fuse to measure current in a circuit.

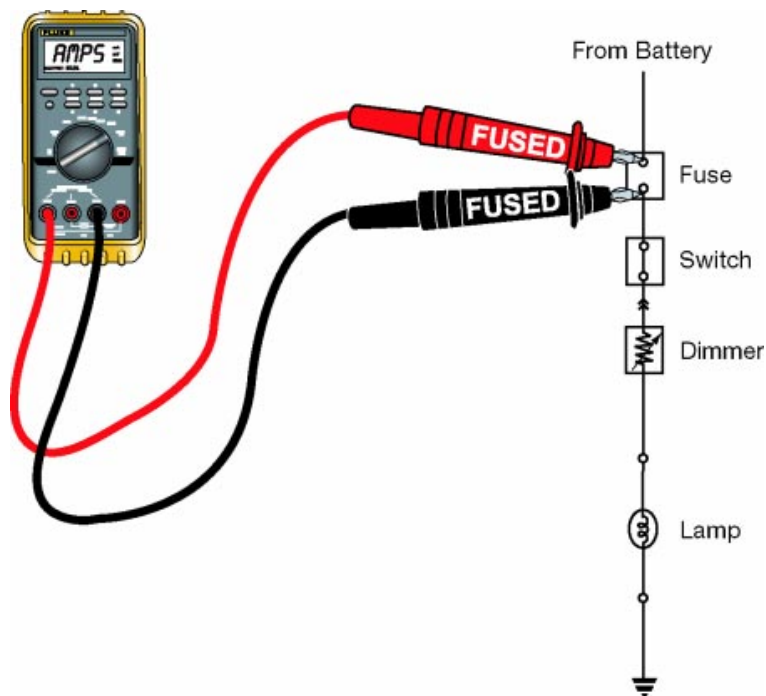

Fig. 2-05
TL623f205c

Current in a series circuit - Current in a series circuit is the same at every point in the circuit.

- Measure current by opening the circuit and inserting the meter in series.
- The circuit now includes the DMM in series with the circuit.
- Use a fused lead if removing the circuit fuse.

Measuring Resistance in a Series Circuit

Remove the fuse before beginning resistance measurements. To test the dimmer, disconnect it from the circuit.

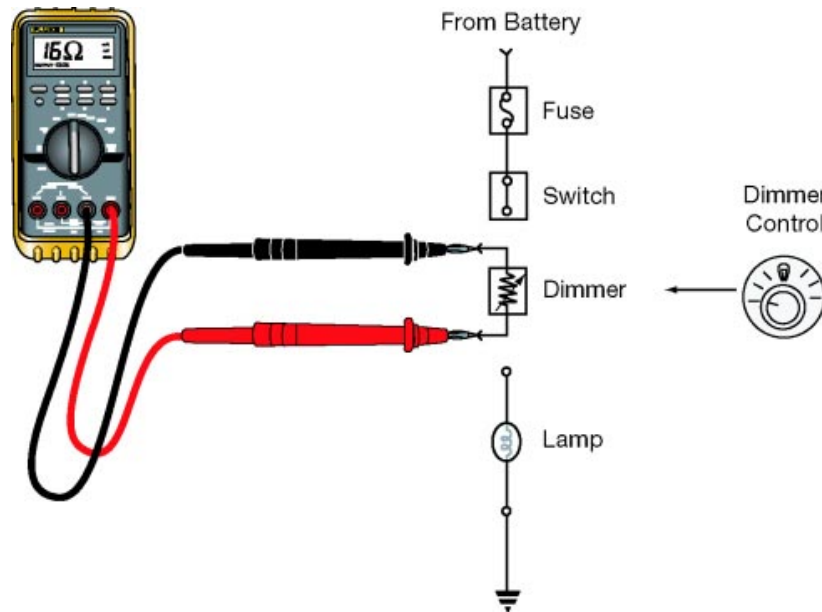

Fig. 2-06
TL623f206c

Resistance in a series circuit - To make resistance measurements:

- Remove power from the circuit (turn it off or pull the circuit fuse).
- Isolate components to be tested from the rest of the circuit (disconnect or remove the component).
- Test suspect components one at a time.

EXAMPLE In the series circuit above, isolate the dimmer for resistance testing.

- Resistance varies as the dimmer knob turns.
- Resistance is highest with the dimmer turned all the way to “Dim.”
- Resistance is lowest with the dimmer turned all the way to “Bright.”

Open Circuit

This open circuit between the dimmer and the lamp means the lamp does not operate at all (a break in the current path).

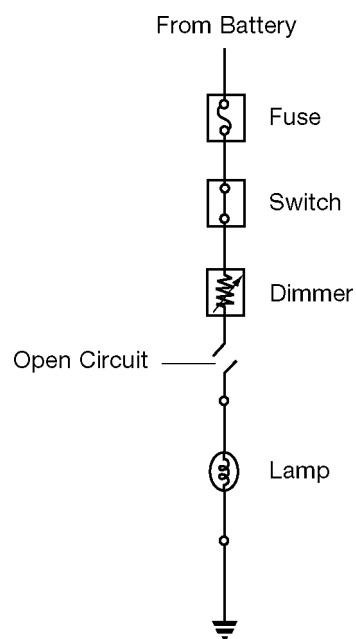

Fig. 2-07
TL623f207

Open circuit - Any break (open) in the current path of a series circuit makes the whole circuit inoperative. Open circuits can be caused by:

- Broken or loose connections
- Cut wire
- Faulty component

Find an Open Circuit

Look for an open circuit by testing for voltage in the circuit. Start with the point closest to the power source (battery) and move toward the circuit ground.

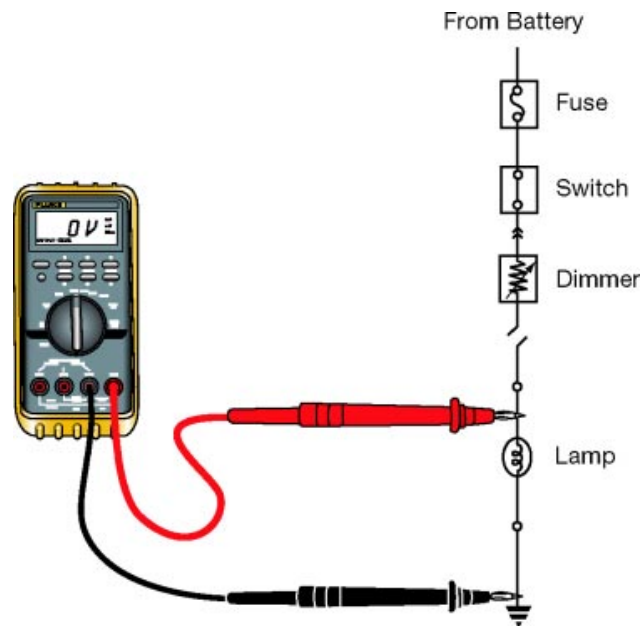

Fig. 2-08
T623f208c

Testing for available voltage - Find the fault in an open circuit by testing for available voltage.

- Begin at the fuse.
- Work your way point by point toward the circuit ground.
- Proceed until you find a point where voltage is no longer present.
- The open circuit is between your last two test points.

Split - Half Method

Circuits with easy access to components can use the split-half method to isolate the problem.

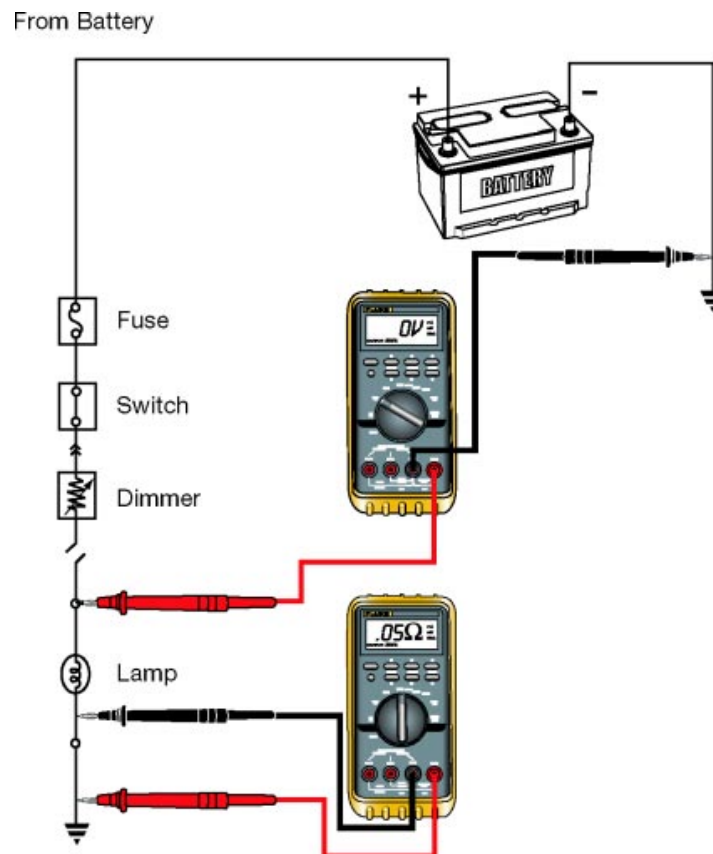

Fig. 2-09
TL623f209c

Split-Half Method - You can use the split-half method on circuits where access to the related components is good. The split-half method works as follows:

- Locate the middle area of the circuit that has the problem.
- Determine if the source (battery +) or ground side of that section of the circuit is bad by the following:
 - Check for available voltage on the source side.
 - Check for continuity to ground on the ground side.
- Split the bad section you found in step 2 in half and repeat the same tests.
- Continue splitting the circuit into smaller halves repeating steps 2 and 3 until you isolate the cause of the problem.

Continuity Check to Find an Open Circuit

Look for an open circuit by testing for continuity. In a logical sequence, check individual segments of the circuit.

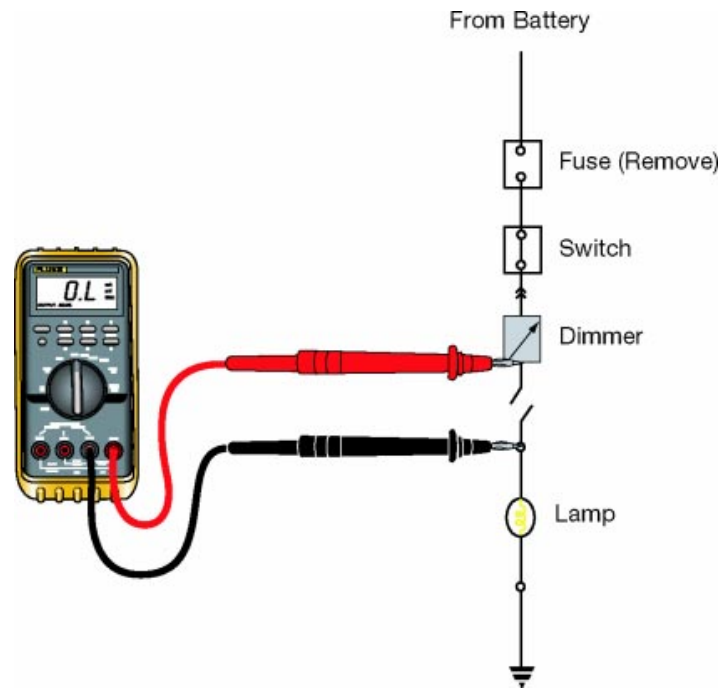

Fig. 2-10
T623f210c

Testing for continuity - The preferred method of testing a circuit is with power applied and checking for voltage drop.

When that is not possible, find the fault in an open circuit by testing for continuity as follows:

- Remove power from the circuit (turn it off or pull the circuit fuse).
- Refer to the wiring diagram to choose individual sections of the circuit for continuity checks.
- Use a DMM to check each section. Isolate components and sections as needed (by disconnecting or removing wires or components).
- Proceed until you find a section that does not show continuity (very high resistance). The open circuit will be in that section.

Short Circuit

The short circuit shown in this diagram is before the load. It provides an unwanted path for current to flow to ground.

In most cases, a short like this increases current so much that it blows the circuit fuse.

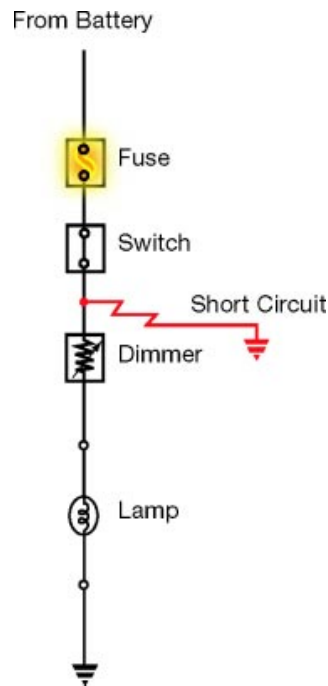

Fig. 2-11
TL623f211c

Short circuit - A short circuit is a fault in the current path. A short can be:

- an unwanted path between two parts of a circuit.
- an unwanted path between part of a circuit and ground.
- an unwanted current path inside a component.
- an unwanted path between two separate circuits.

Excessive current - Short circuits may cause excessive current.

- This typically blows the circuit fuse.
- It may not be possible to troubleshoot the circuit under power.

Isolate a short circuit - To isolate a short circuit, disconnect sections or components of the circuit one at a time.

- Refer to the electrical wiring diagram to determine a logical sequence of testing.
- Use continuity checks to find and isolate unwanted current paths.

Isolating a Short Circuit

You can troubleshoot a short circuit with continuity checks, or you can use a sealed beam headlight in the isolation method shown here.

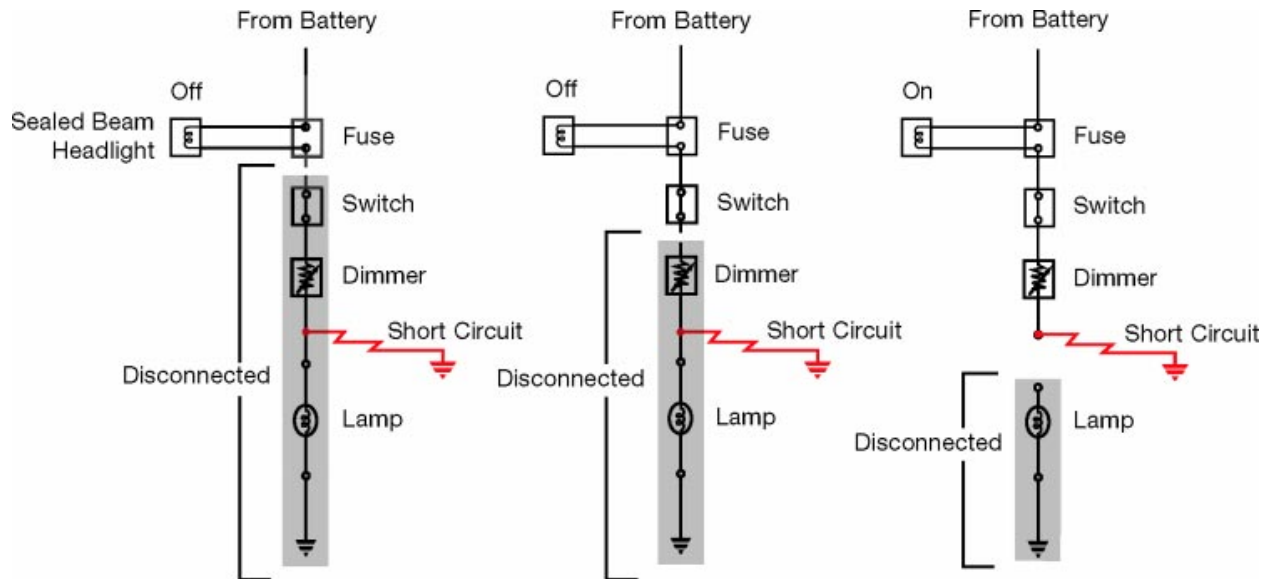

Fig. 2-12
TL623f212c

Isolating a short circuit - Circuit breakers and short detectors may damage some circuits. The following method works well for locating most short circuits:

- Remove the related fuse.
- Jumper in a sealed beam headlight to the fuse connections (the headlight becomes the load in the circuit allowing you to isolate the area with the short).
- Apply power to the circuit and the headlight will illuminate.
- Isolate sections of the circuit until the headlight turns off. This pinpoints what section of the circuit the short is in.
- Inspect that section of the circuit to locate the cause of the short.
- Repair the cause of the short.
- Remove the headlamp and reinstall the fuse.
- Verify proper circuit operation.

Parallel Circuit

In this diagram, each lamp is in its own parallel branch of the circuit. This makes it possible for one lamp to operate while the other is inoperative.

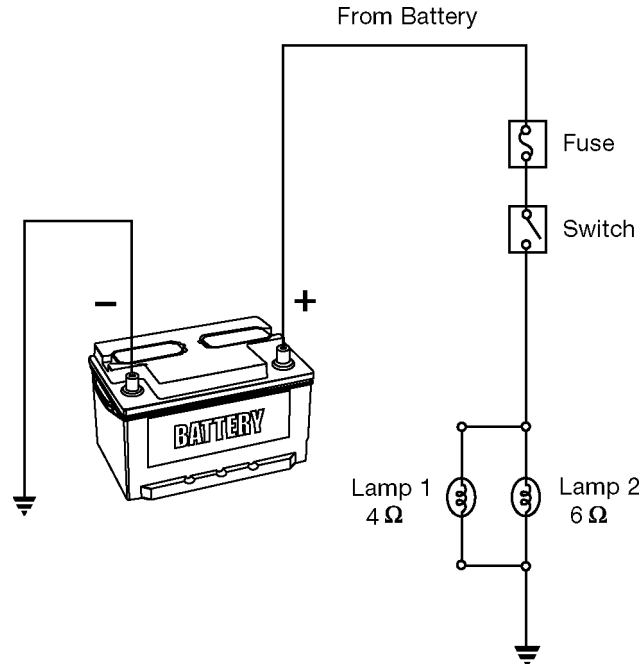

Fig. 2-13
TL623f213

Key Features A parallel circuit has these key features:

- Total current equals the sum of the branch currents.
- Resistance of each branch determines the current through each branch.
- If the branch resistances are the same, branch currents will be the same.
- If the branch resistances are different, the current in each branch will be different.
- The voltage drop across each load resistance is the same. This is because the source voltage is applied equally to each branch.
- The equivalent resistance of the circuit is less than the smallest branch resistance.

Parallel circuit operation - The circuit shown above resembles an automotive brake light circuit.

- When the switch is open, voltage is applied to the open contact of the switch. No current flows.
- When the switch is closed, current flows through the switch and both lamps to ground. The lamps light.

Parallel Circuit Elements

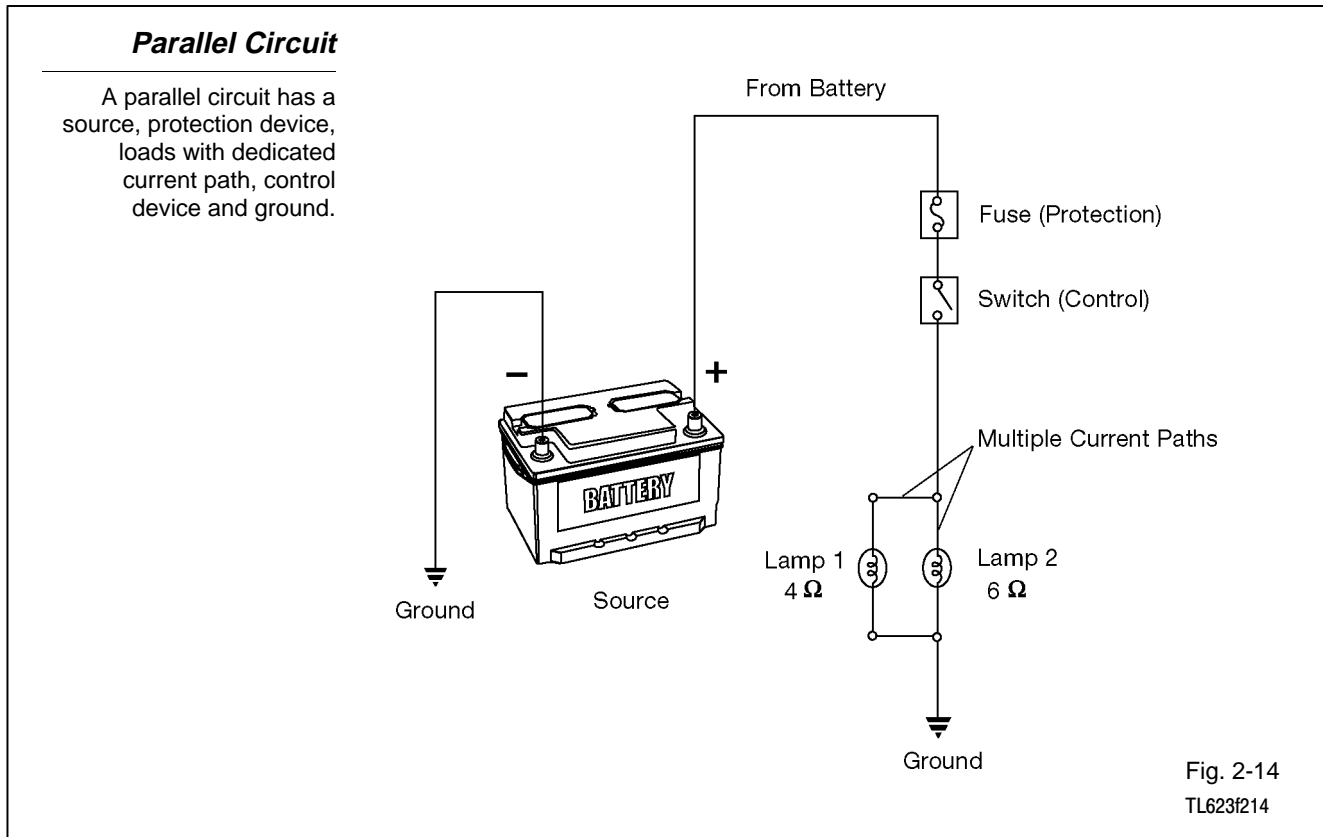

A parallel circuit contains all the elements of a series circuit:

- Power source
- Protection device
- Load
- Control device
- Ground

However, a parallel circuit has more than one path for current. It typically has two or more loads, and it may have multiple control devices.

The circuit loads are connected in parallel paths called “branches.” Each branch operates independently of the others. In a parallel circuit, it is possible for one load to be inoperative while other loads continue to operate.

Ohm's law in Parallel Circuits

You can use Ohm's law to predict circuit behavior. Total resistance is less than the smallest branch resistance. Voltage drop in each branch equals source voltage.

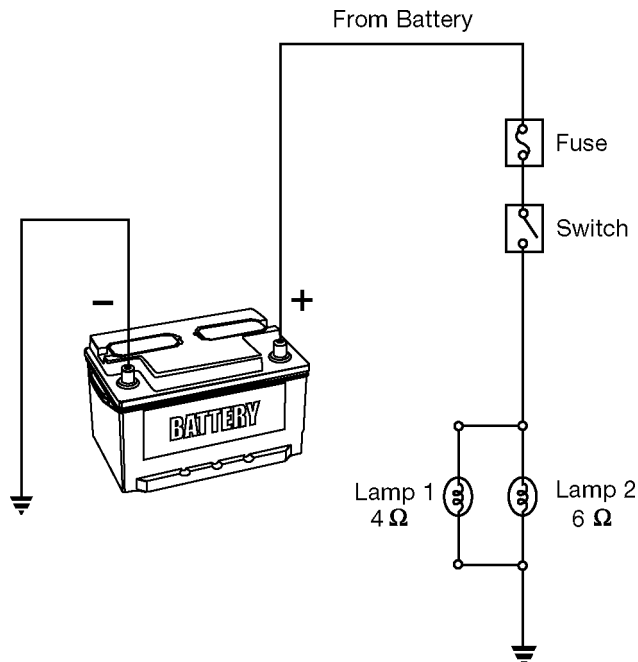

Fig. 2-15
TL623f215

Applying Ohm's Law - You can use Ohm's Law to predict the behavior of electricity in a circuit.

For parallel circuits, apply Ohm's Law as follows:

- The total (or equivalent) resistance (R) is less than the smallest branch resistance.

$$R_T = \frac{R_1 \times R_2}{R_1 + R_2}$$

- When you add a branch resistance to a parallel circuit, the equivalent resistance of the circuit decreases.
- When you remove a branch, the equivalent resistance increases.
- Voltage drop across each branch in the circuit is the same.

Use Ohm's Law to troubleshoot circuits:

- If there is an open circuit in one or more of the branches, the increased equivalent resistance will reduce current.
- Increasing resistance in one branch may affect only the component operation in that branch. However, if the resistance goes high enough to create an open circuit, the circuit effectively loses a branch. In that case, equivalent resistance increases and current decreases for the entire circuit.
- Increased resistance in the series segment of the circuit can also reduce current. Low source voltage can also reduce current.
- As in series circuits, high source voltage or a short circuit to ground before the load can increase current, blow fuses, and damage components.

Current in Parallel Circuits

Total current in the circuit equals the sum of current in each branch.

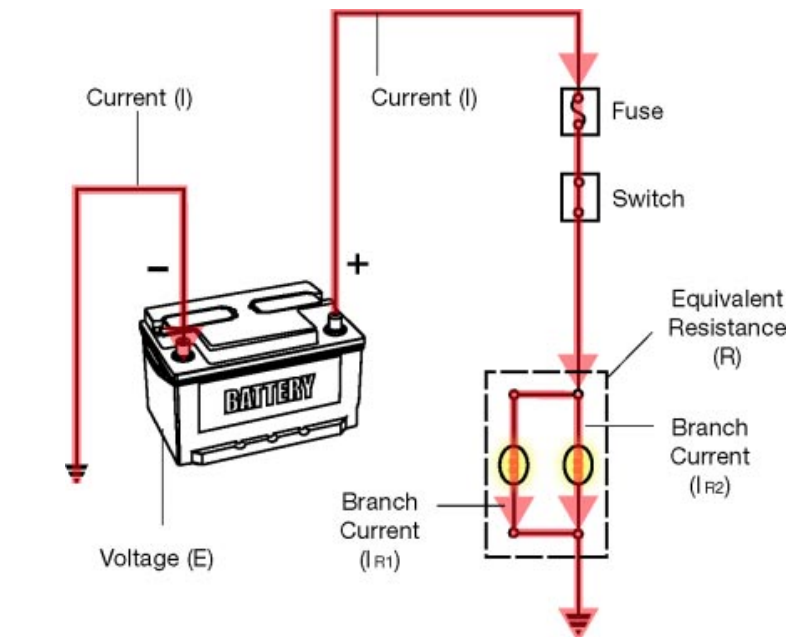

Fig. 2-16
TL623f216c

Current - Current in a parallel circuit behaves differently than it does in a series circuit.

- Current through the fuse and the switch is the same.

Current through the lamps is split.

- If the lamps have equal resistance, current through the lamps is identical.
- If the lamps have unequal resistance, the lamp with lower resistance conducts more current than the lamp with higher resistance.
- If one lamp fails, the other lamp will still work and conduct the same amount of current as before.
- Total current in the circuit does change when one bulb fails.

Parallel Circuit Tests

Diagnose parallel circuits using the DMM to measure voltage, amperage, and resistance.

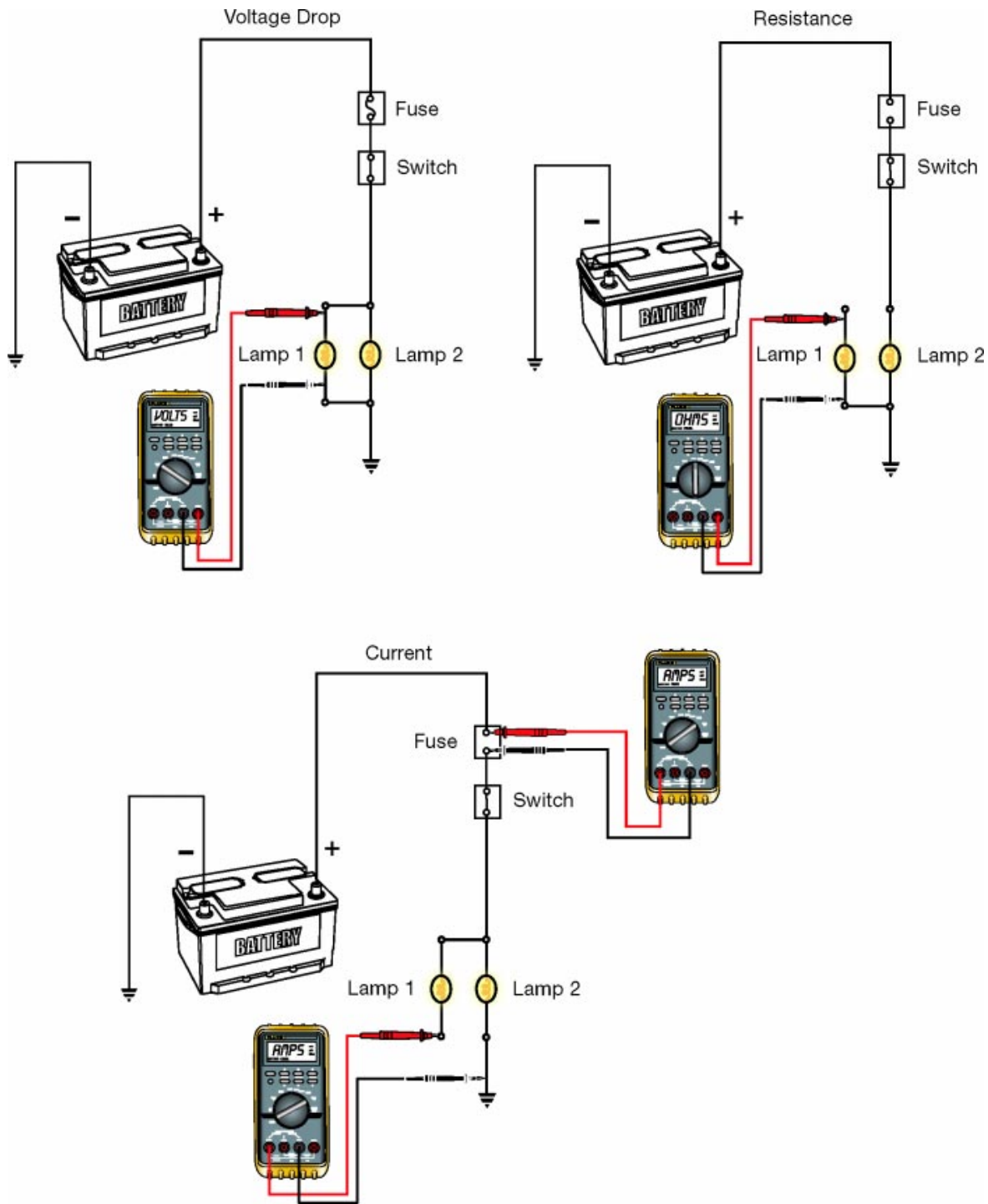

Fig. 2-17
TL623f217c

Parallel circuit tests - Use these guidelines to measure current, voltage, and resistance in parallel circuits:

- Voltage drops across parallel components and branches will be equal, even if their resistance is different.
- Measure total circuit current in a parallel circuit just as you would measure it in a simple series circuit.
- Measure branch current by inserting the DMM into a point in the branch to be measured (branch current will flow through the DMM to be measured).
- Isolate branches when checking continuity or measuring resistance (this avoids inaccurate measurement results).
- Total circuit resistance will be less than the lowest resistance branch in that circuit.

Parallel circuit troubleshooting - Observe the operation of a parallel circuit to gain clues about the fault.

- If one lamp works and the other doesn't ...
 - You know the battery, fuse, and switch are all operating correctly.
 - The fault is in the parallel branch that contains the non-functioning lamp.
- If neither lamp works ...
 - The most likely location for the fault is in the series portion of the circuit (between the battery and the point where the current paths split for the lamps).
 - It is possible that both lamps are burnt out, but this is not the most likely fault.

Series-Parallel Circuits

These are the three basic circuit types. The series-parallel circuit combines a series segment (fuse, switch, dimmer) with two parallel branches (lamps).

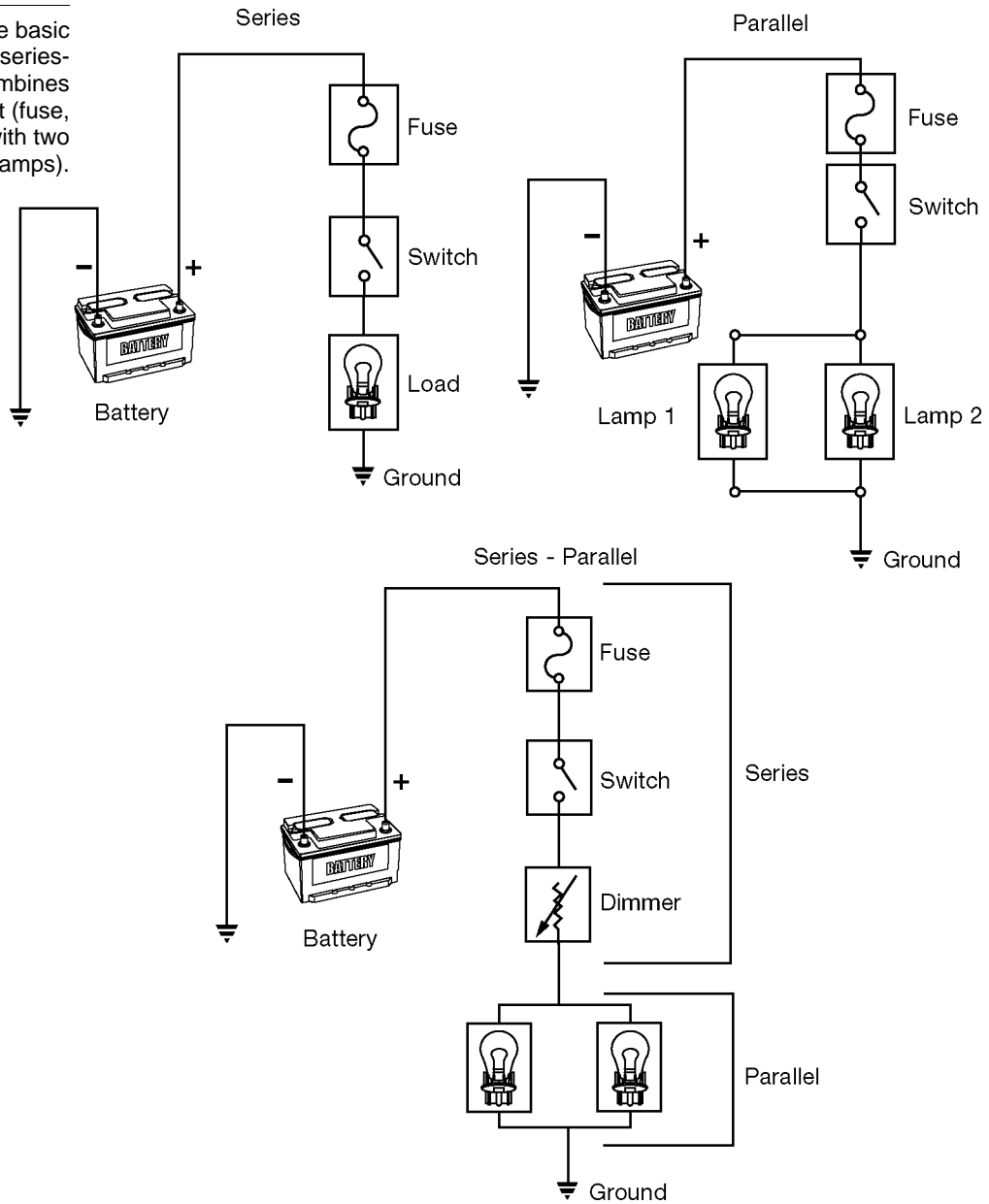

Fig. 2-18
TL623f218

Key Features A series-parallel circuit has these key features:

- Current in the series segment equals the sum of the branch currents.
- Circuit resistance is the sum of the parallel equivalent resistance plus any series resistances.
- Voltage applied to the parallel branches is the source voltage minus any voltage drop across loads in the series segment of the circuit.

Series-Parallel Circuits Combinations - Most automotive circuits combine series and parallel segments.

- A series circuit has a single path for current.
- A parallel circuit has multiple paths for current.
- A series-parallel circuit combines both series and parallel sections.

Current - In a series-parallel circuit, current flows through the series segment and then splits to flow through the parallel branches of the circuit.

Applying Ohm's Law - You can use Ohm's Law to predict the behavior of electricity in a circuit.

For series-parallel circuits, apply Ohm's Law as follows:

- Calculate the circuit resistance.
 - Calculate the equivalent resistance of the parallel branches.
 - Add any series resistances to the equivalent resistance.
- Calculate current (I) by dividing the source voltage (E) by the circuit resistance (R).
 - $I = E/R$
- Calculate individual voltage drops by multiplying the current times the load resistance.
 - $E = I \times R$

Use Ohm's Law to troubleshoot series-parallel circuits:

- Faults in the series segment of the circuit will affect operation of the entire circuit.
- Increasing resistance in one branch may affect only the component operation in that branch. However, if the resistance goes high enough to create an open circuit, the circuit effectively loses a branch. In that case, equivalent resistance increases and current decreases for the entire circuit.
- Increased resistance in the series segment of the circuit can also reduce current. Low source voltage can also reduce current.
- High source voltage or a short circuit to ground before the load can increase current, blow fuses, and damage components.

Dimmer switch circuit - The simplified instrument panel wiring diagram shown here is typical of series-parallel circuits.

- The dimmer switch controls instrument panel bulb brightness.
- Equal currents flow through the two back-up lights to ground.

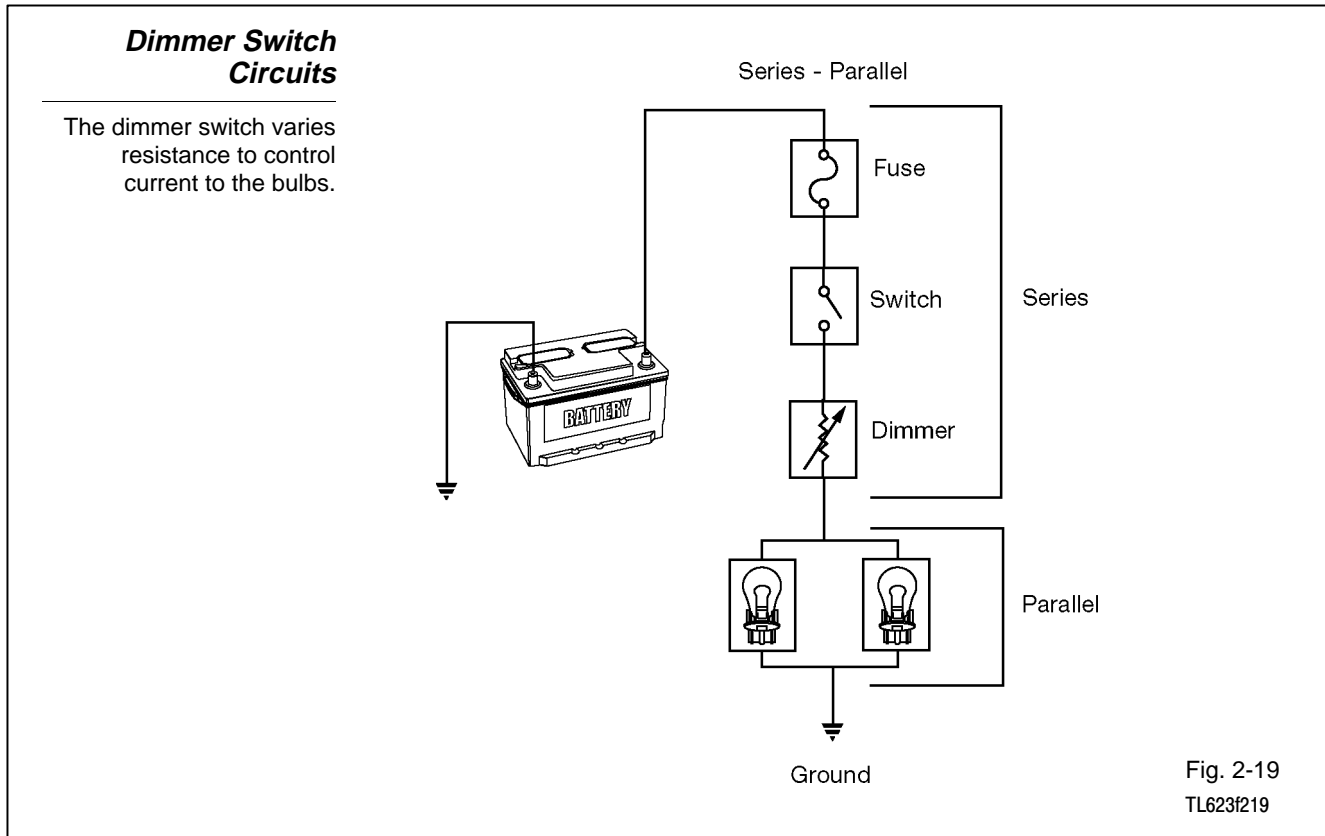

Circuit connections - Various devices connect components in series and parallel segments:

- Splices
- Connectors
- Junction blocks

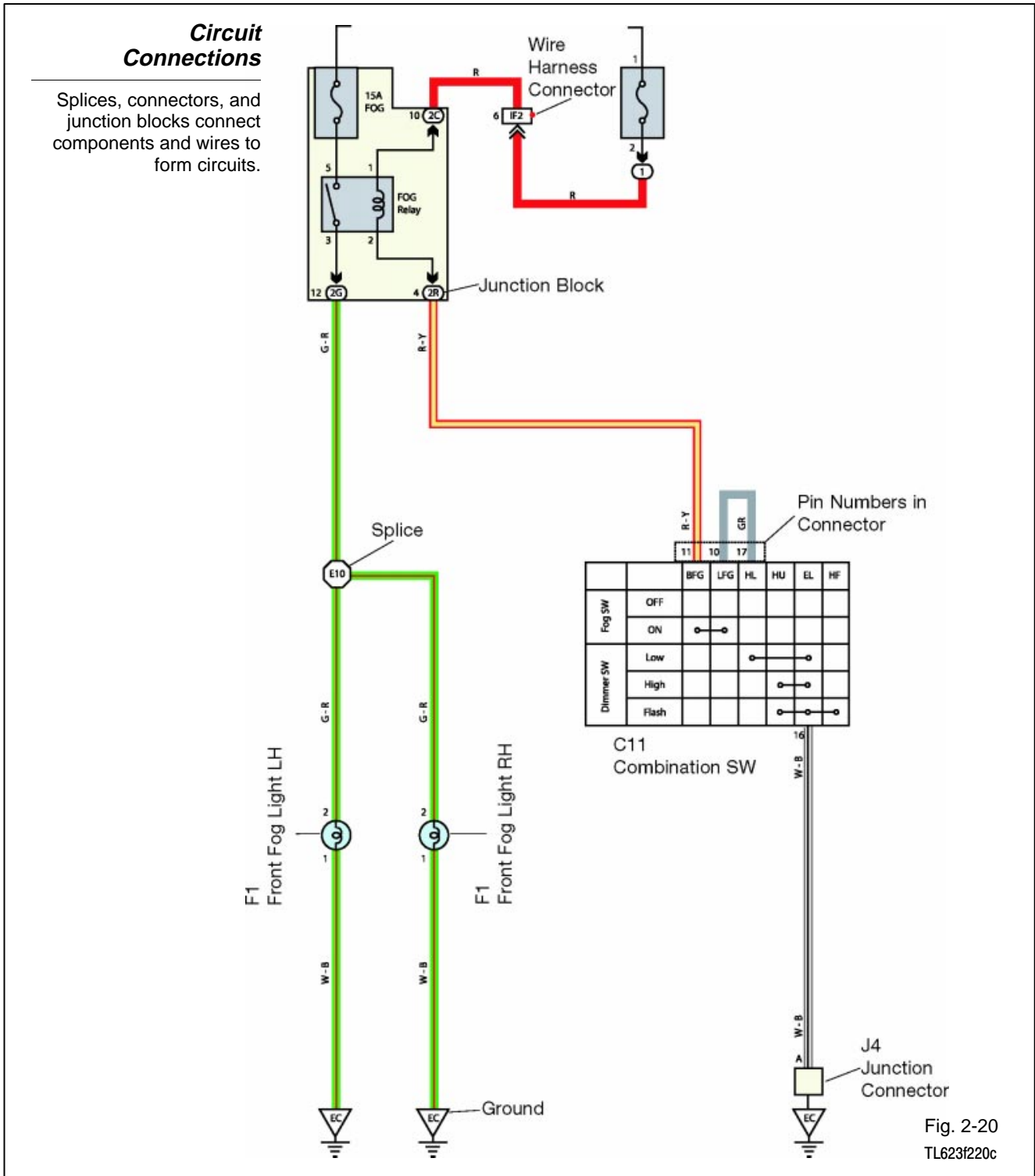

Load Control Source or Ground

Switching devices control current in circuits:

- Relays
- Diodes
- Transistors
- Electronic components
- Switches

These switching devices can be placed to control the source side or the ground side of a circuit:

- Source side - control device between the voltage source and the load.
- Ground side - control device between the load and ground.

The back-up lights circuit shown here is an example of a source control circuit.

Source Control Circuit

Switches, diodes, relays, transistors, and other electronic components can interrupt the flow of current to control a load. The switch in this circuit controls power to the back-up lights.

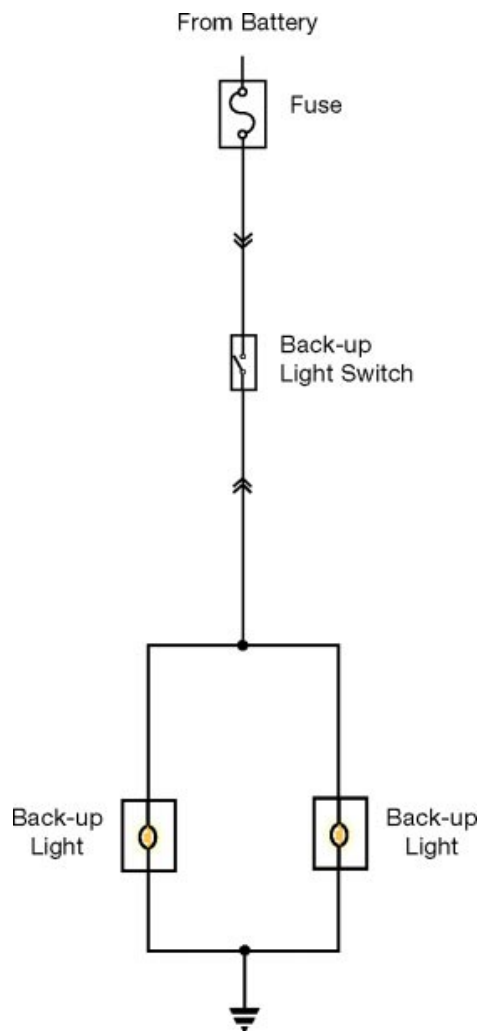

Fig. 2-21
TL623f221c

Ground Control Circuit

The switch in this circuit controls current from the relay coil to ground.

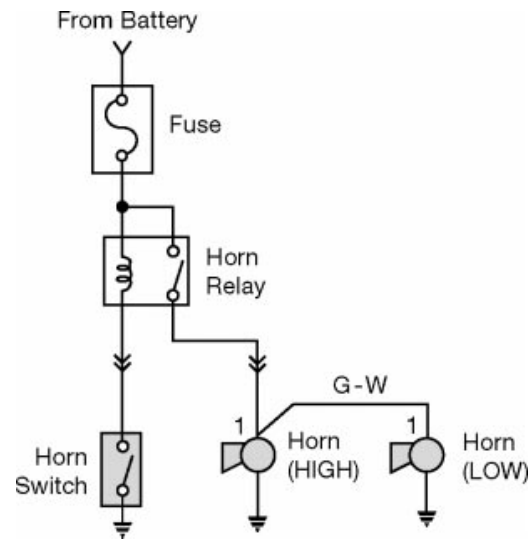

Fig. 2-22
TL623f222

Ground control - The horn circuit shown here is an example of a ground control circuit.

Electrical Symbols

Electrical Symbols

These are some of the symbols used in Toyota Electrical Wiring Diagrams.

GLOSSARY OF TERMS AND SYMBOLS









 <p>BATTERY Stores chemical energy and converts it into electrical energy. Provides DC current for the auto's various electrical circuits.</p>	 <p>GROUND The point at which wiring attaches to the body, thereby providing a return path for an electrical circuit; without a ground, current cannot flow.</p>
 <p>CAPACITOR (Condenser) A small holding unit for temporary storage of electrical voltage.</p>	 <p>HEADLIGHTS Current flow causes a headlight filament to heat up and emit light. A headlight may have either a single (1) filament or a double (2) filament.</p>
 <p>CIGARETTE LIGHTER An electric resistance heating element.</p>	 <p>HORN An electric device which sounds a loud audible signal.</p>
 <p>CIRCUIT BREAKER Basically a reusable fuse, a circuit breaker will heat and open if too much current flows through it. Some units automatically reset when cool, others must be manually reset.</p>	 <p>IGNITION COIL Converts low-voltage DC current into high-voltage ignition current for firing the spark plugs.</p>
 <p>DIODE A semiconductor which allows current flow in only one direction.</p>	

Fig. 2-23
TL623f223

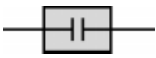
Standardized electrical symbols allow wiring diagrams to efficiently convey information about automotive electrical and electronic circuits.

Technicians must understand these symbols to use the electrical wiring diagrams for troubleshooting Toyota vehicles. Toyota Electrical Wiring Diagram (EWD) manuals incorporate a “How to Use this Manual” section. Refer to this section if there are any questions about using electrical wiring diagrams.

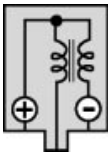
Wiring Diagrams Wiring diagrams let you see the fuses, components, wires, and connectors, as well as the power and ground connections that make up each circuit.

Each diagram's layout helps you to quickly understand how the circuit works and how you can troubleshoot electrical faults.

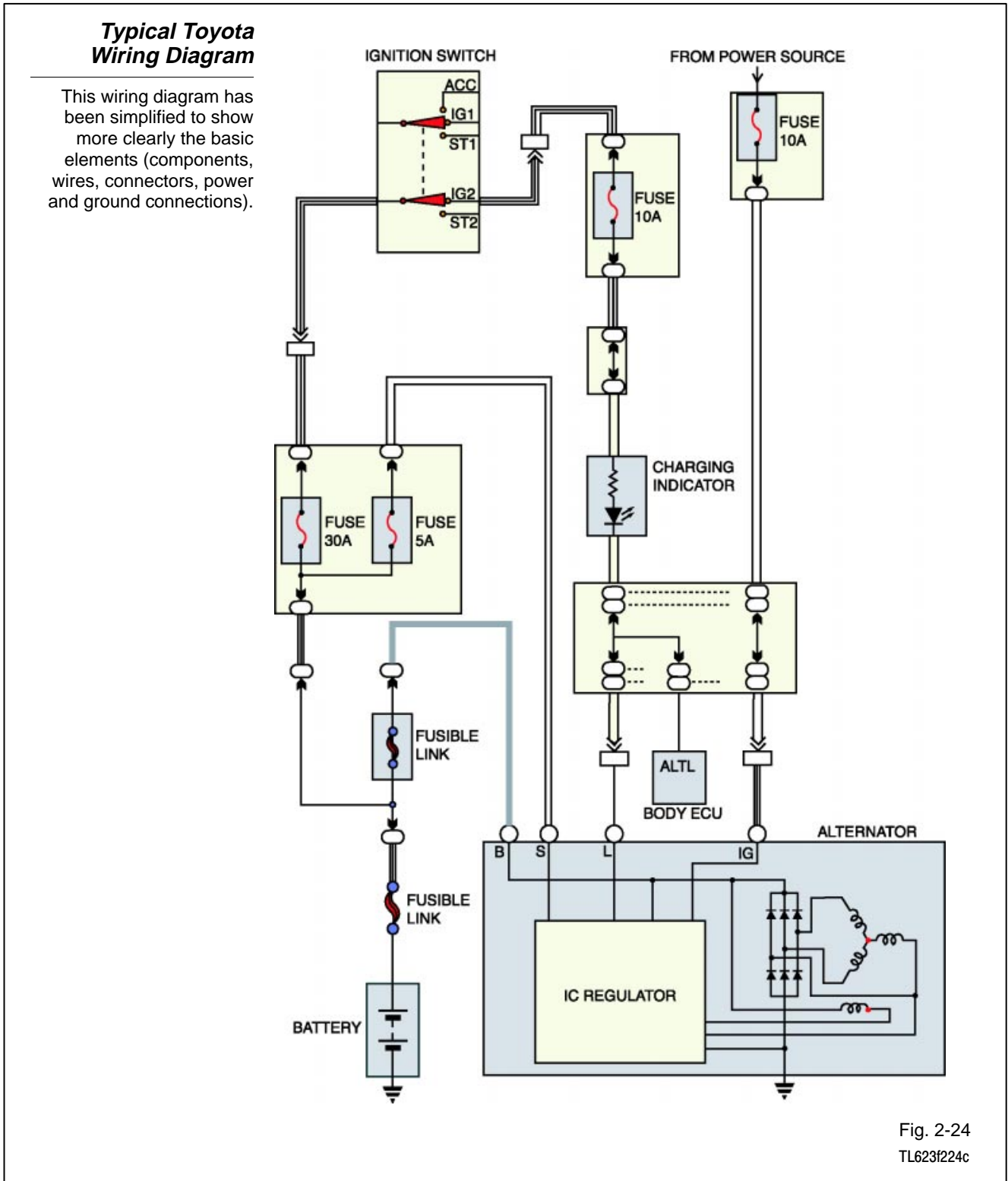

You must know how to read Toyota wiring diagrams in order to effectively diagnose and repair electrical systems on Toyota vehicles.

Skilled technicians use electrical wiring diagrams to:

- Determine how a particular system operates.
- Predict voltage or resistance values for selected test points.
- Find the locations of components, relays, fuses, junction blocks, terminals, and connectors.
- Identify pin assignments in connectors and junction blocks.
- Determine wire colors and locations.
- Check for common points using the power source and ground points diagrams.

Inductors

Inductors

These components are inductors. They all use electromagnetism to work.

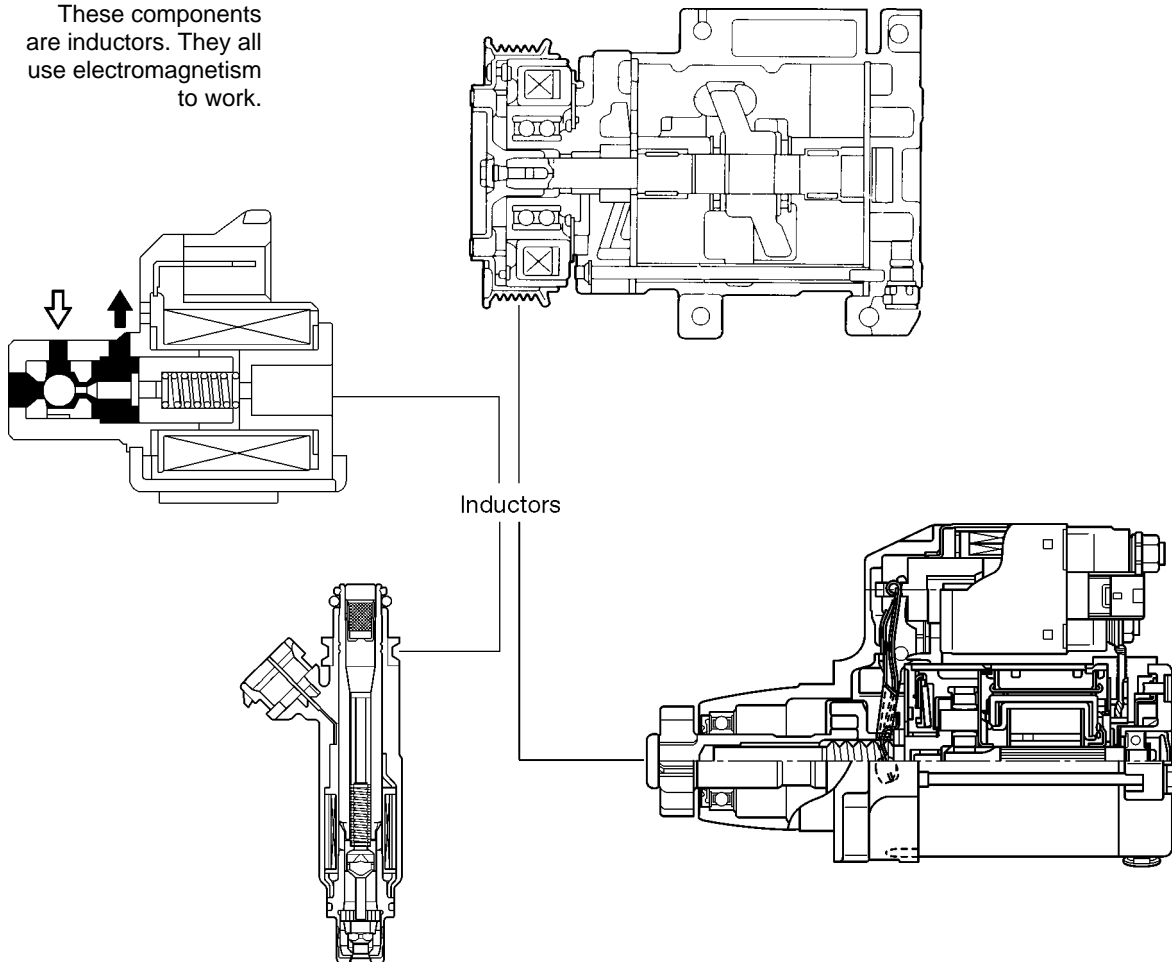

Fig. 2-25
TL623f225

Solenoids, relays, motors, and coils:

- Are in a class of devices called “inductors.”
- Use electromagnetism to do work.

A Simple Electromagnet

A simple electromagnet can be made from a length of wire, a battery, and a nail. Depending on the size of the battery, this circuit might require some added resistance to keep excess current from burning the wire.

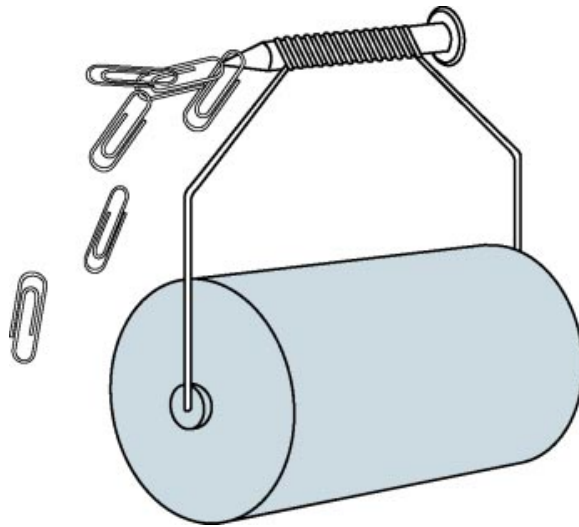

Fig. 2-26
TL623f226

Electromagnetism - Electricity can create magnetism.

- Current flowing through a conductor creates a magnetic field.
- It is possible to concentrate that magnetic field by wrapping the conductor into a coil.

You can create a simple electromagnet:

- Wrap an insulated wire around a nail (or a metal rod).
- Connect a battery to the wire.
- When current flows through the nail, you will see that it behaves like a magnet.

Applications of Electromagnetism

Motors, solenoids, and coils all use windings of wire.

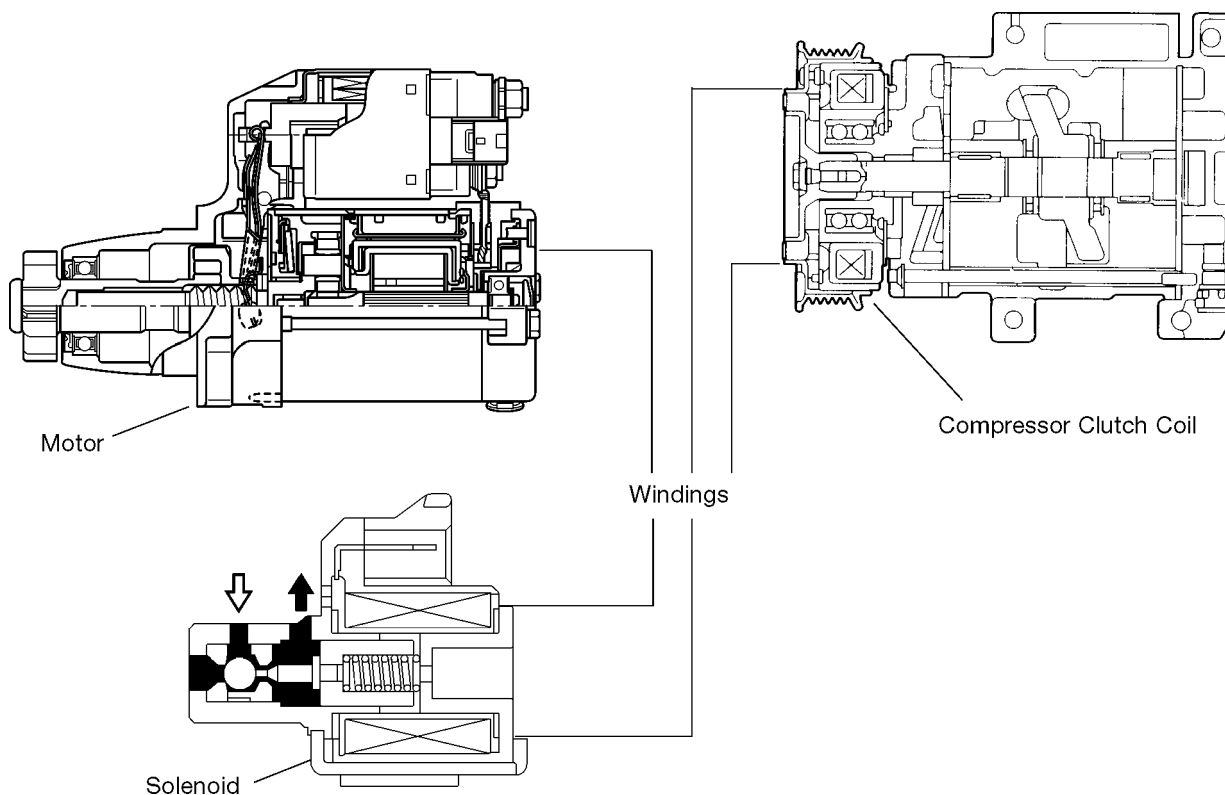

Fig. 2-27
TL623f227

Applications of electromagnetism - Automotive electrical systems use electromagnetism in various ways:

- A solenoid uses a coil of wire to generate a magnetic field that moves a plunger.
- A relay incorporates a coil to open and close one or more switch contacts.
- A generator uses windings to create current.
- A motor uses windings to create motion.

Voltage Generated by Induction

When a current flowing through a coil is cut off, the collapsing magnetic field generates a voltage spike.

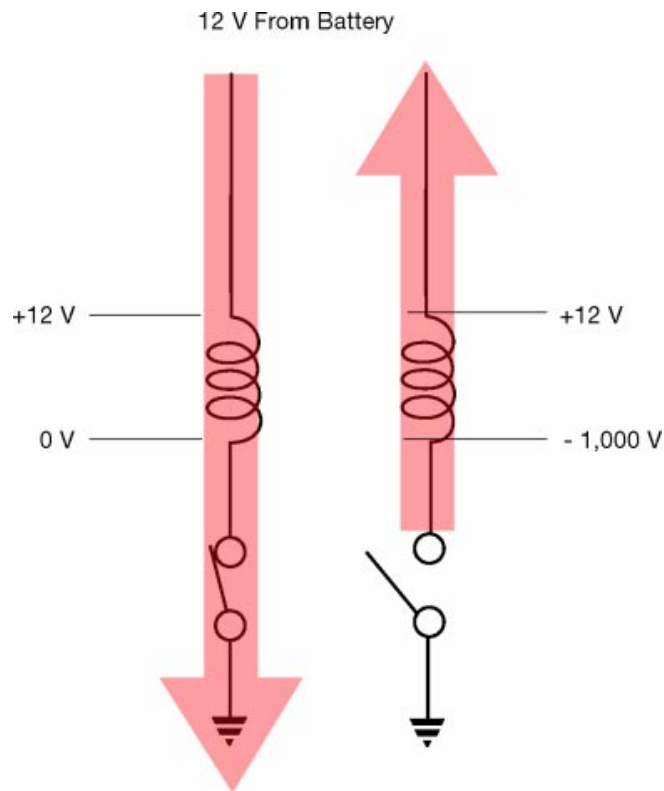

Fig. 2-28
TL623f228c

Inductor coil control devices - These control devices can turn coils on and off as needed to control solenoids and relays:

- Switch
- Transistor
- Electronic control unit (ECU)

Voltage spikes - Coils can generate voltage spikes as they are turned off.

- An inductor coil generates a magnetic field when current is present.
- This magnetic field starts to collapse the instant current stops.
- The collapsing magnetic field produces a large momentary voltage called a *transient* or a voltage spike.
- The voltage spike can be powerful enough to damage electronic components.

EXAMPLE A 12-volt relay can generate a voltage spike of 1000 to 1500 volts as its coil is switched off.

Suppression diode/resistor - A diode or resistor wired in parallel with a coil suppresses voltage spikes.

Ignition Coil

An ignition coil takes advantage of the collapsing magnetic field to generate a high voltage pulse for the spark plugs.

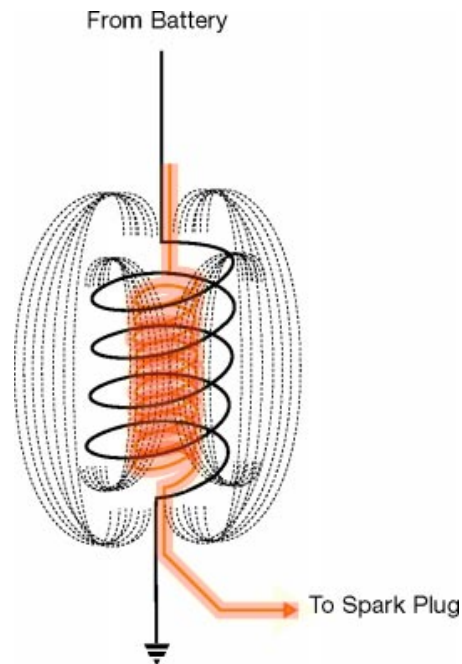
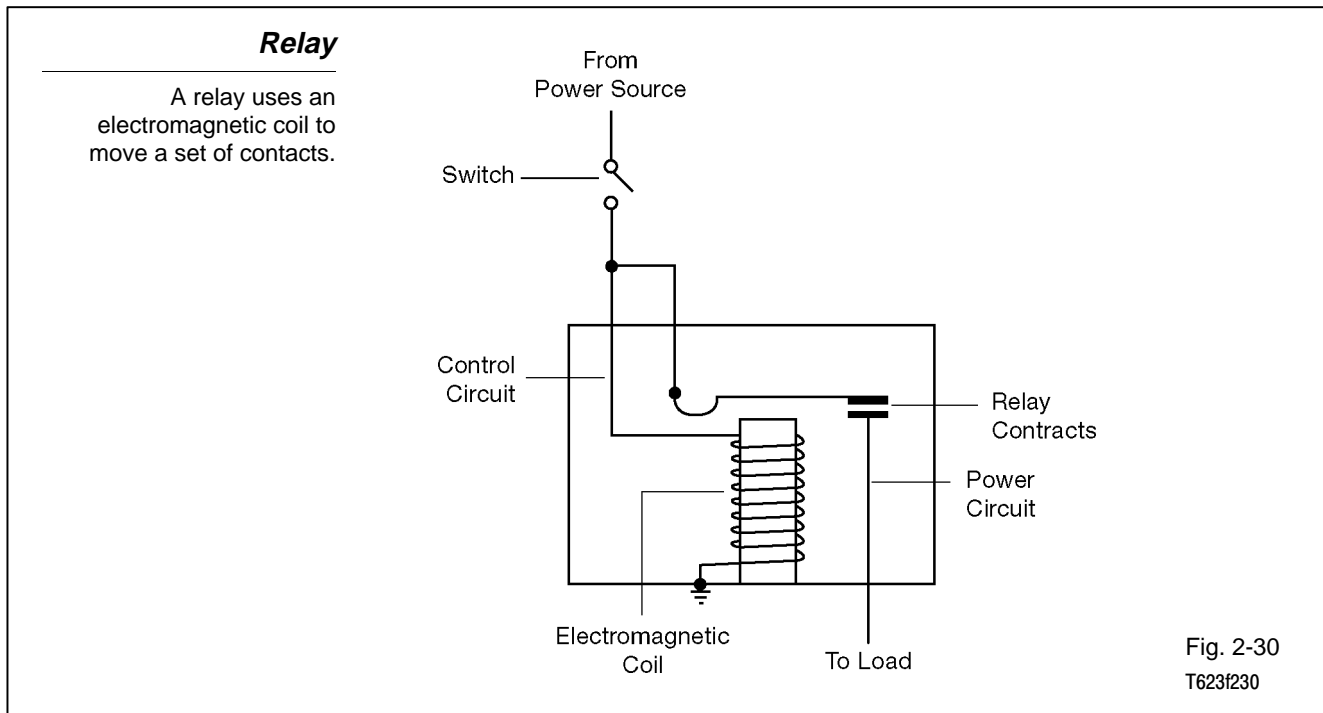

Fig. 2-29
TL623f229c

Ignition coil - An ignition coil is one type of inductor.

- An ignition coil contains two windings:
 - Primary
 - Secondary
- The secondary winding has hundreds of times more turns than the primary.
- Current flows from the battery through the primary winding of the ignition coil to ground.
- The primary winding generates a magnetic field that encompasses the secondary winding.
- When current through the primary winding is cut off, its magnetic field collapses rapidly.
- The collapsing magnetic field induces a very high voltage (up to 100,000 volts) in the secondary winding. The voltage is so high because of the number of turns in the secondary winding.
- The secondary winding delivers this high voltage to the spark plug(s).



Relay - A relay functions as a remote-control switch. It uses a small current to control a larger current. A typical application for a relay is to control a load that requires a large current with a switch that controls a small current. Using a relay for remote switching has these advantages:

- Relay coil can be operated with a small current.
- Relay contacts can control (switch) a large current.
- Relay allows use of a switch to operate a component that is some distance away from where the switch needs to be (horn, for example).
- The small current control circuit saves weight and reduces wire size in wiring harnesses.

Current typically flows through two separate paths in the relay.

- Control circuit (small current)
- Power circuit (larger current)

The control circuit contains the relay's electromagnetic coil. It is typically controlled by a switch in the current path between the power source and the coil or between the coil and ground (more common in Toyota circuits). The power circuit contains one or more relay contacts. When the relay coil is energized, it moves the contacts. Depending on the relay type, the contacts may open or close as the relay coil energizes:

- Normally open contacts - close when relay coil energizes.
- Normally closed contacts - open when relay coil energizes.

Engine Compartment Relay Block

Most relays are grouped into relay blocks. This one is located in the engine compartment.

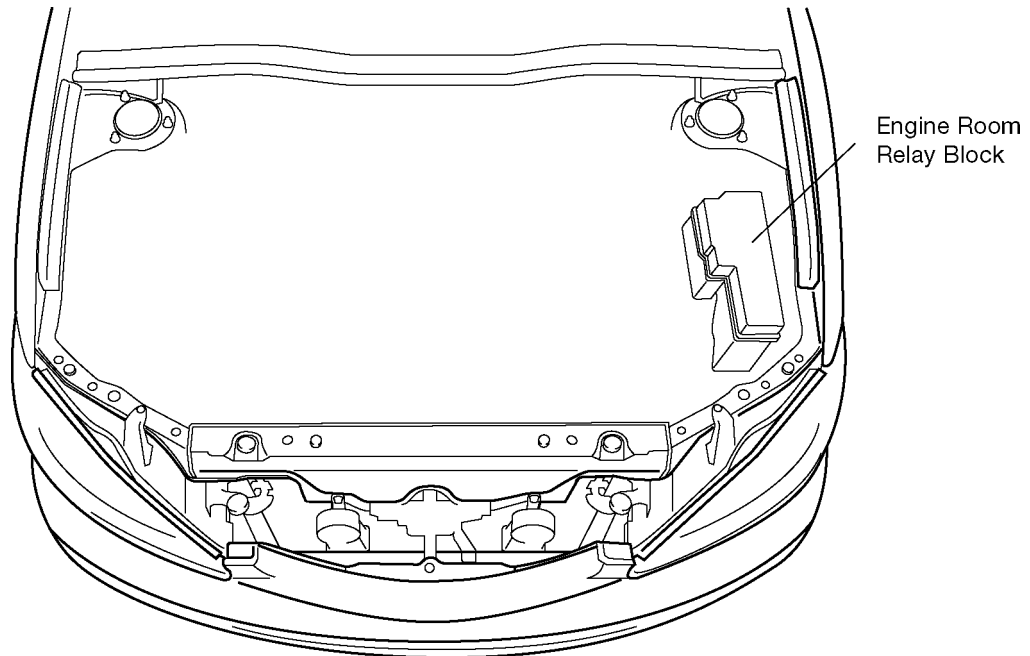

Fig. 2-31
TL623f231

Relay location - Relay blocks are found at various locations in Toyota vehicles:

- In the engine compartment
- Behind the right or left kick panel
- Under the dash

Refer to the appropriate EWD or TIS for specific relay identification and location.

Relay checks - There are a number of ways you can check a relay:

- **CONTINUITY** - Use an ohmmeter or DMM to confirm that the relay contacts are open (no continuity) and closed (continuity) as required.
- **VOLTAGE** - Use a voltmeter or DMM to confirm that the relay contacts block voltage and pass voltage as required.
- **OPERATIONAL** - If the relay controls more than one load, determine if other loads operate when relay closes the circuit.

Refer to the appropriate wiring diagram to determine whether the contacts are normally open or closed.

DMM limitations - A typical DMM has very high internal resistance.

- This high resistance means the meter puts out a very small test current (normally an advantage).
- Small test current can cause inaccurate test results with relay contacts.
- If the contacts are partially burned or corroded, the DMM may show good continuity or voltage and yet the relay may not operate correctly.

NOTE

Many relays produce an audible click as the coil closes or opens the contacts. This is not a reliable test for proper operation. Even a malfunctioning relay may produce a click.

Relay Operational Check

A DMM should measure voltage at the relay's (normally open) output contact when the relay coil is energized.

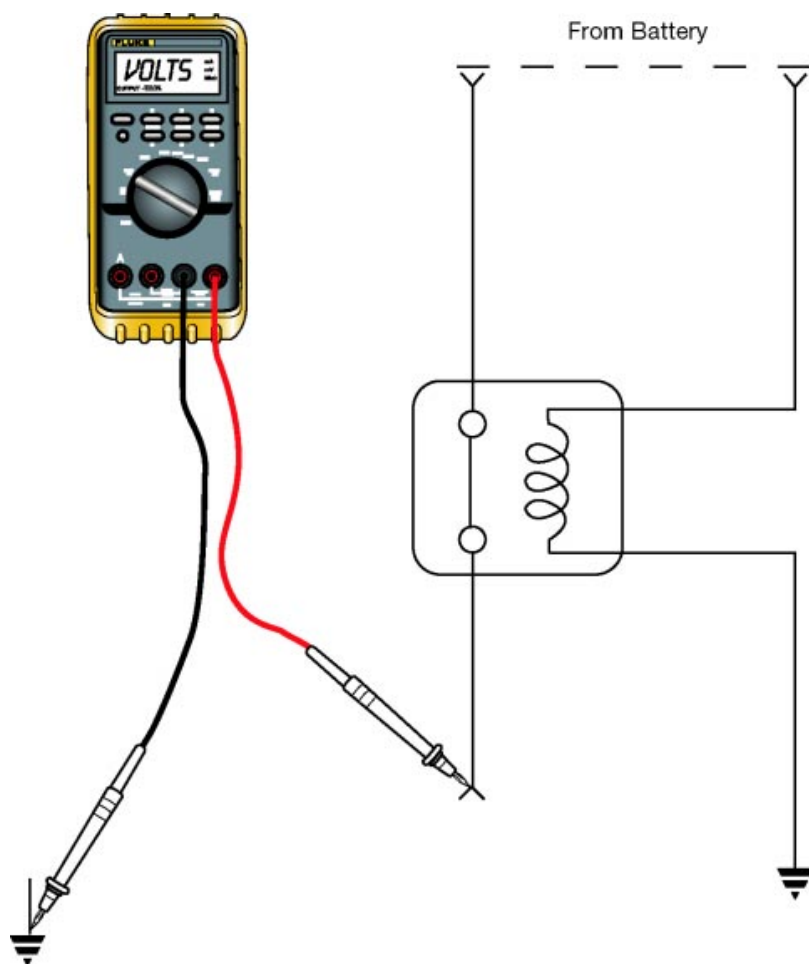

Fig. 2-32
TL623f232c

Inductors Controlled by Electronic Components

Components with electromagnetic coils are sometimes called “actuators” when they are controlled by an ECU.

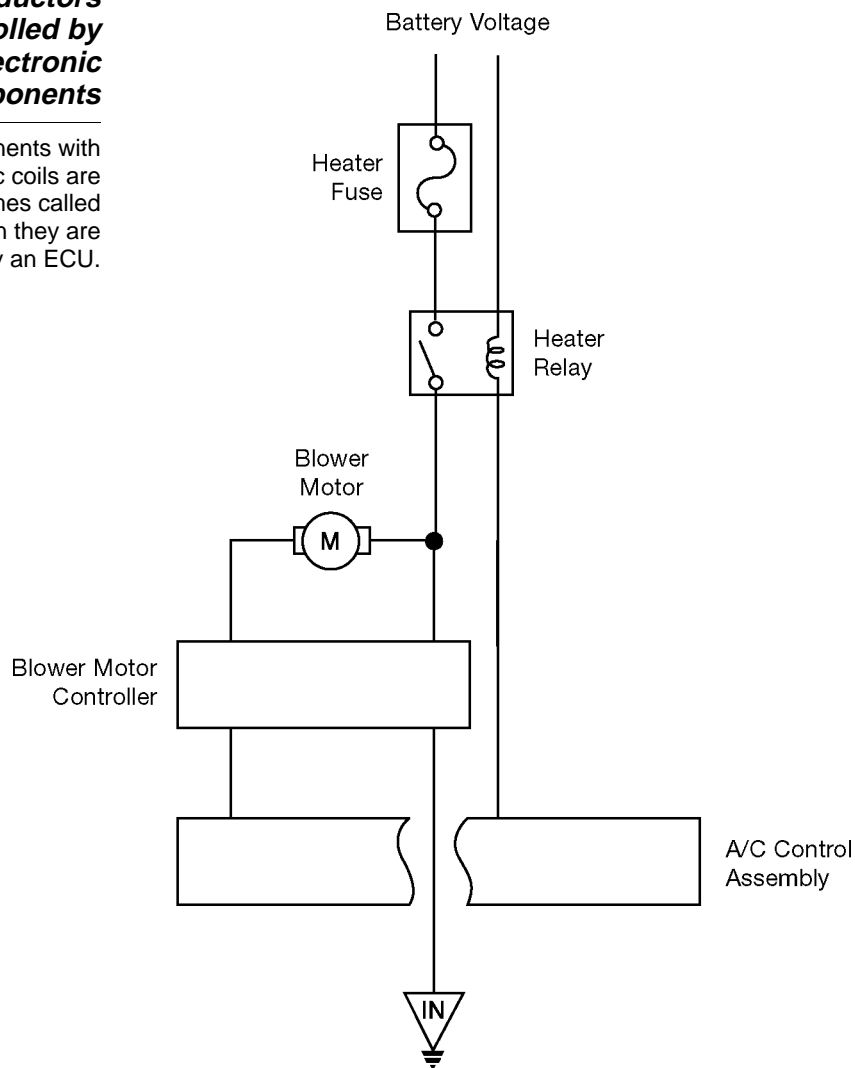

Fig. 2-33
TL623f233

Inductors controlled by electronic components - Components with electromagnetic coils are sometimes called “actuators” when they are controlled by an Electronic Control Unit (ECU). Keep these things in mind when dealing with actuators:

- A short circuit in an actuator can allow excess current to flow in the circuit.
- Excess current can damage electronic components, such as ECUs.
- Any time an ECU has failed, confirm that all actuators under its control are operating correctly and are not shorted.

NOTE

Diagnostic procedures for electronic components are covered in detail in Courses 652 and 852.

Vehicle Wiring Terminal and Connector Repair

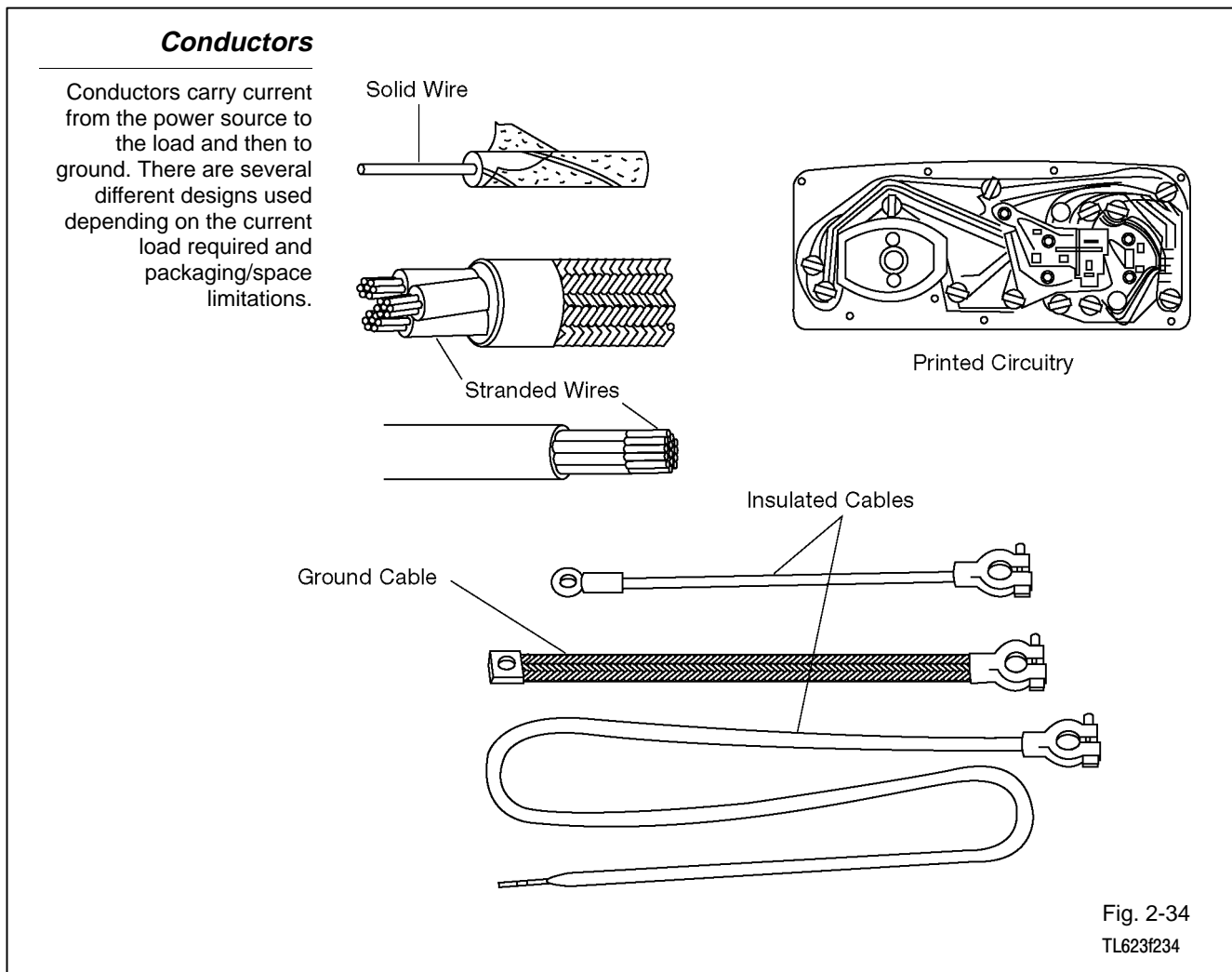

Conductors Conductors allow electrical current to flow from the power source to the working devices and back to the power source.

Power or Insulated Conductors Conductors for the power or insulated current path may be solid wire, stranded wire, or printed circuit boards. Solid, thin wire can be used when current is low. Stranded, thick wire is used when current is high. Printed circuitry — copper conductors printed on an insulating material with connectors in place — is used where space is limited, such as behind instrument panels.

Special wiring is needed for battery cables and for ignition cables. Battery cables are usually very thick, stranded wires with thick insulation. Ignition cables usually have a conductive carbon core to reduce radio interference.

Ground Paths Wiring is only half the circuit in Toyota electrical systems. This is called the “power” or insulated side of the circuit. The other half of the path for current flow is the vehicle’s engine, frame, and body. This is called the ground side of the circuit. These systems are called single-wire or ground-return systems.

A thick, insulated cable connects the battery’s positive (+) terminal to the vehicle loads. As insulated cable connects the battery’s negative (-) cable to the engine or frame. An additional grounding cable may be connected between the engine and body or frame.

Resistance in the insulated side of each circuit will vary depending on the length of wiring and the number and types of loads. Resistance on the ground side of all circuits must be virtually zero. **This is especially important:** ground connections must be secure to complete the circuit. Loose or corroded ground connections will add too much resistance for proper circuit operation.

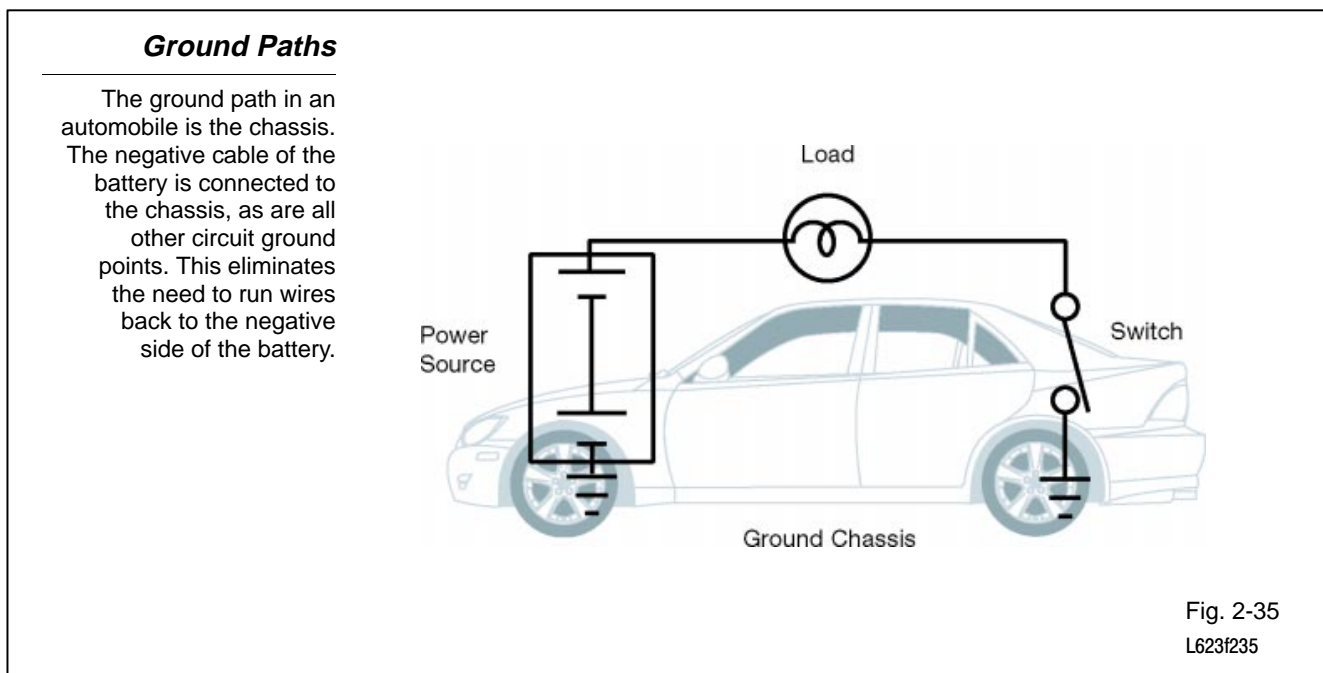

System Polarity System polarity refers to the connections of the positive and negative terminals of the battery to the insulated and ground sides of the electrical system. On Toyota vehicles, the positive (+) battery terminal is connected to the insulated side of the system. This is called a **negative ground system having positive polarity**.

Knowing the polarity is extremely important for proper service. Reversed polarity may damage alternator diodes, cause improper operation of the ignition coil and spark plugs, and may damage other devices such as electronic control units, test meters, and instrument-panel gauges.

Harnesses Harnesses are bundles of wires that are grouped together in plastic tubing, wrapped with tape, or molded into a flat strip. The colored insulation of various wires allows circuit tracing. While the harnesses organize and protect wires going to common circuits, don't overlook the possibility of a problem inside.

Harnesses

A harness is a group of wires inside a protective covering. These wires supply current to several components often in the same general area of the vehicle.

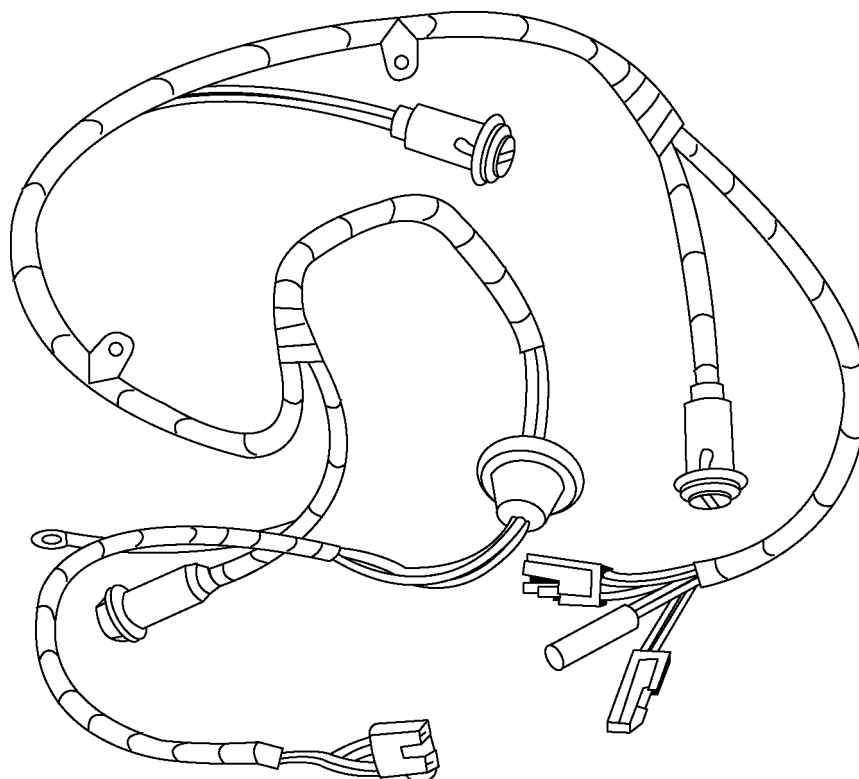
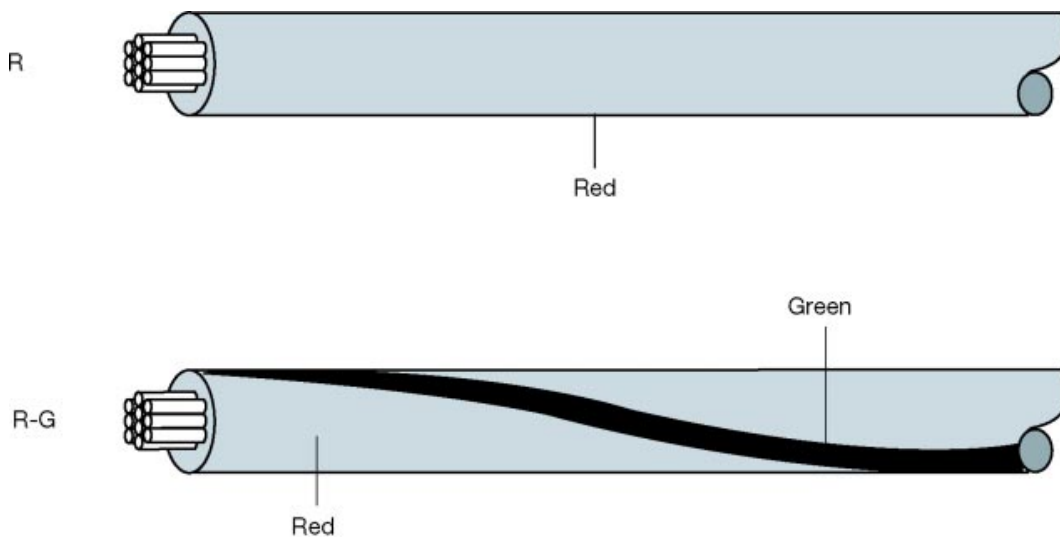

Fig. 2-36
TL623f236

Wire Insulation Conductors must be insulated with a covering or “jacket.” This insulation prevents physical damage, and more important, keeps the current flow in the wire. Various types of insulation are used depending on the type of conductor. Rubber, plastic, paper, ceramics, and glass are good insulators.

Wire Insulation

Wires are insulated to protect from moisture, dirt, and other contaminants. The wires must also be shielded from other wires, and the chassis ground, to prevent short circuits.



Wiring Color Code

Wire Colors are indicated by an alphabetical code.

B = Black	L = Blue	R = Red
BR = Brown	LG = Light Green	V = Violet
G = Green	O = Orange	W = White
GR = Gray	P = Pink	Y = Yellow

The first letter indicates the basic wire color and the second letter indicates the color of the stripe.

Fig. 2-37
TL623f237

Connectors Various types of connectors, terminals, and junction blocks are used on Toyota vehicles. The wiring diagrams identify each type used in a circuit. Connectors make excellent test points because the circuit can be “opened” without need for wire repairs after testing. However, never assume a connection is good simply because the terminals seem connected. Many electrical problems can be traced to loose, corroded, or improper connections. These problems include a missing or bent connector pin.

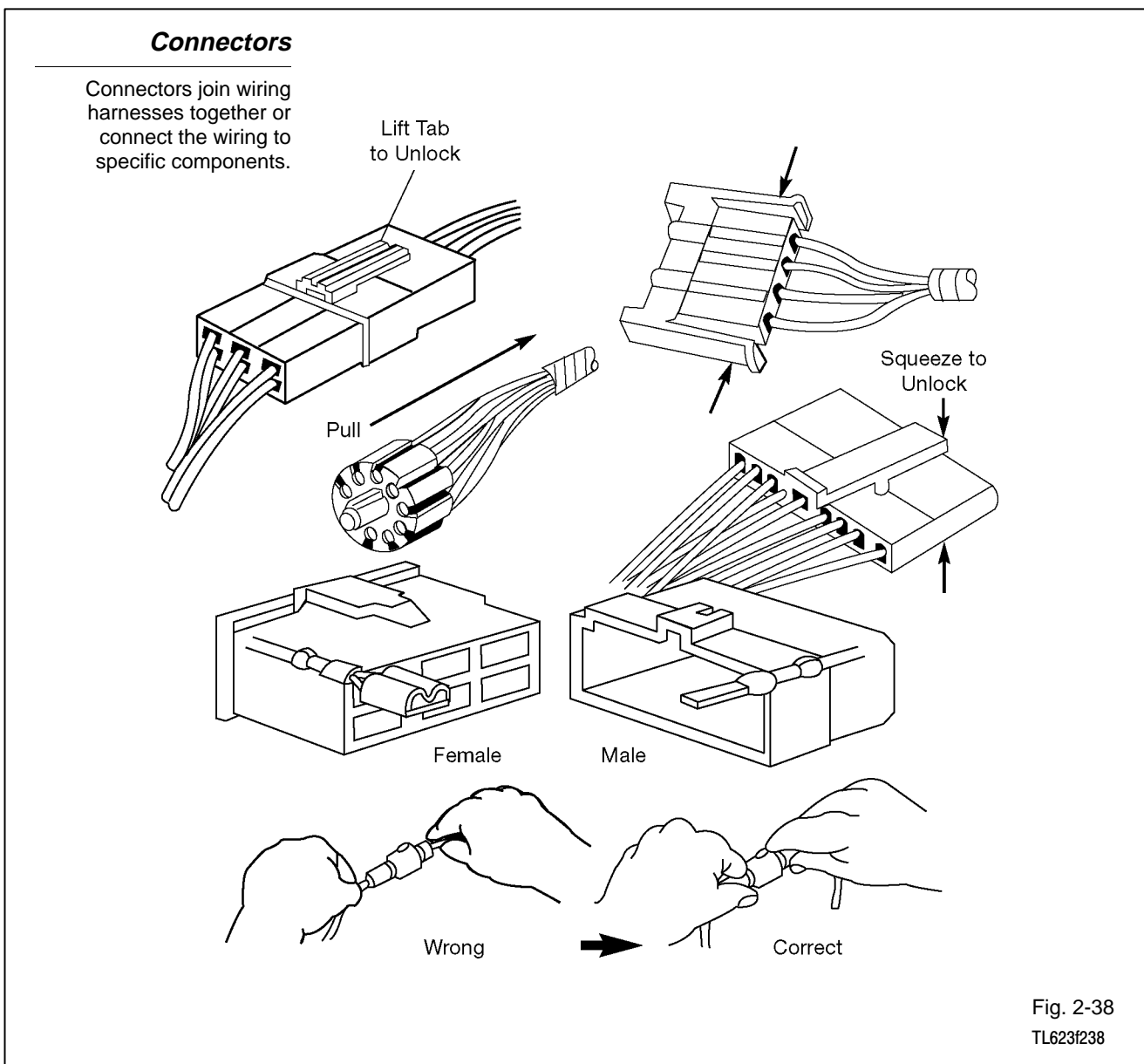

SRS Harness Components

Supplemental Restraint System (SRS) airbag harness insulation and the related connectors are usually color coded yellow or orange. Do not connect any accessories or test equipment to SRS related wiring.

Warning: Supplemental Restraint System (SRS) airbag harness components, including wiring, insulation and connectors, are not repairable. Any SRS harness component damage requires replacement of the related harness. Refer to the service information in TIS or the Repair Manual when diagnosing SRS.

SRS Wiring

Supplemental Restraint System wiring, harnesses and connectors are identified by yellow or orange connectors or insulation wrapping. Do not repair any SRS wiring or connectors. Replace any damaged components with a new harness.



Fig. 2-39
TL623f239

Connector Repair The repair parts now in supply are limited to those connectors having common shapes and terminal cavity numbers. Therefore, when there is no available replacement connector of the same shape or terminal cavity number, please use one of the alternative methods described below. Make sure that the terminals are placed in the original order in the connector cavities, if possible, to aid in future diagnosis.

1. When a connector with a **different number of terminals** than the original part is used, select a connector having more terminal cavities than required, and replace both the male and female connector parts.

EXAMPLE You need a connector with six terminals, but the only replacement available is a connector with eight terminal cavities. Replace both the male and female connector parts with the eight-terminal part, transferring the terminals from the old connectors to the new connector.

2. When several **different type terminals** are used in one connector, select an appropriate male and female connector part for each terminal type used, and replace both male and female connector parts.

EXAMPLE You need to replace a connector that has two different types of terminals in one connector. Replace the original connector with two new connectors, one connector for one type of terminal, another connector for the other type of terminal.

3. When a different shape of connector is used, first select from available parts a connector with the appropriate number of terminal cavities, and one that uses terminals of the same size as, or larger than, the terminal size in the vehicle. The wire lead on the replacement terminal must also be the same size as, or larger than, the nominal size of the wire in the vehicle. (“Nominal” size may be found by looking at the illustrations in the back of this book or by direct measurement across the diameter of the insulation). Replace all existing terminals with the new terminals, then insert the terminals into the new connector.

EXAMPLE You need to replace a connector that is round and has six terminal cavities. The only round replacement connector has three terminal cavities. You would select a replacement connector that has six or more terminal cavities and is not round, then select terminals that will fit the new connector. Replace the existing terminals, then insert them into the new connector and join the connector together.

Conductor Repairs Conductor repairs are sometimes needed because of wire damage caused by electrical faults or by physical abuse. Wires may be damaged electrically by short circuits between wires or from wires to ground. Fusible links may melt from current overloads. Wires may be damaged physically by scraped or cut insulation, chemical or heat exposure, or breaks caused during testing or component repairs.

Conductor Damage

Wires may be damaged by repeated movement or being cut by road debris for example. Short circuits may overheat wiring causing additional damage.

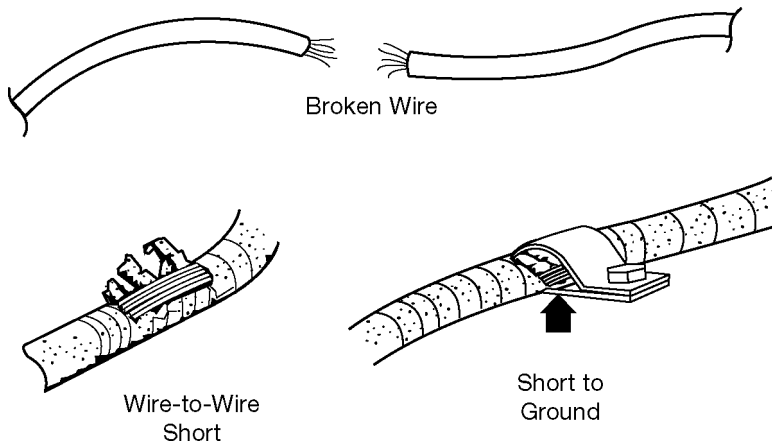

Fig. 2-40
TL623f240

Wire Size Choosing the proper size of wire when making circuit repairs is critical. While choosing wires too thick for the circuit will only make splicing a bit more difficult, choosing wires too thin may limit current flow to unacceptable levels or even result in melted wires. Two size factors must be considered: **wire gauge number** and **wire length**.

American Wire Gauge Sizes

<u>Gauge Size</u>	<u>Conductor Diameter (Inch)</u>	<u>Cross Section Area (Circular Mils)</u>
20	.032"	1,020
16	.051"	2,580
12	.081"	6,530
8	.128"	16,500
2	.258"	66,400
0	.325"	106,000
2/0	.365"	133,000

<u>AWG Size</u>	<u>Metric Size (mm²)</u>
20	0.5
18	0.8
16	1.0
14	2.0
12	3.0
10	5.0
8	8.0
6	13.0
4	19.0

Wire Gauge Number Wire gauge numbers are determined by the conductor's cross-section area.

In the American Wire Gauge system, "gauge" numbers are assigned to wires of different thicknesses. While the gauge numbers are not directly comparable to wire diameters and cross-section areas, higher numbers (16, 18, 20) are assigned to increasingly thinner wires and lower numbers (1, 0, 2/0) are assigned to increasingly thicker wires. The chart shows AWG gauge numbers for various thicknesses.

Wire cross-section area in the AWG system is measured in circular mils. A mil is a thousandth of an inch (0.001). A circular mil is the area of a circle 1 mil (0.001) in diameter.

In the metric system used worldwide, wire sizes are based on the cross-section area in square millimeters (mm²). These are not the same as AWG sizes in circular mils. The chart shows AWG size equivalents for various metric sizes.

NWS - Nominal Wiring Size is used in the wire repair kit charts.

Wire Length Wire length must be considered when repairing circuits because resistance increases with longer lengths. For instance, a 16-gauge wire can carry an 18-amp load for 10 feet without excessive voltage drop. But, if the section of wiring being replaced is only 3-feet long, an 18-gauge wire can be used. Never use a heavier wire than necessary, but, more important, never use a wire that will be too small for the load.

Wire Repairs

- Cut insulation should be wrapped with tape or covered with heat-shrink tubing. In both cases, overlap the repair about $\frac{1}{2}$ inch on either side.
- If damaged wire needs replacement, make sure the same or larger size is used. Also, attempt to use the same color. Wire strippers will remove insulation without breaking or nicking the wire strands.
- When splicing wires, make sure the battery is disconnected. Clean the wire ends. Crimp and solder them using rosin-core, **not acid-core** solder.

Wire Stripper

A wire stripper is used to correctly remove the insulation from the wire. Other methods often result in damage to the wire itself which can affect the current carrying capacity of the wire.

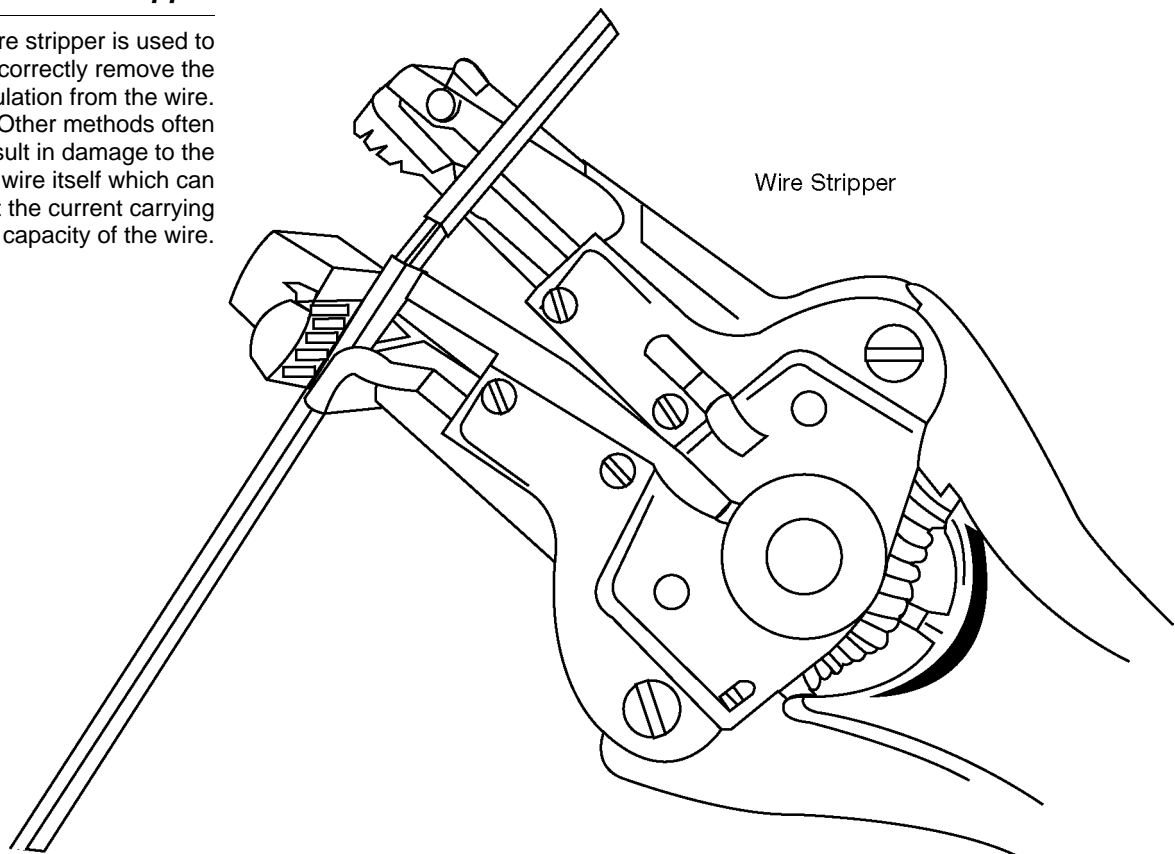

Fig. 2-41
TL623f241

Soldering Soldering joins two pieces of metal together with a lead and tin alloy.

In soldering, the wires should be spliced together with a crimp. The less solder separating the wire strands, stronger the joint.

Solder Solder is a mixture of lead and tin plus traces of other substances.

Flux core wire solder (wire solder with a hollow center filled with flux) is recommended for electrical splices.

Soldering Flux Soldering heats the wires. In so doing, it accelerates oxidization, leaving a thin film of oxide on the wires that tends to reject solder. Flux removes this oxide and prevents further oxidation during the soldering process.

Rosin or resin-type flux **must be used for all electrical work**. The residue will not cause corrosion, nor will it conduct electricity.

Soldering Irons The soldering iron should be the right size for the job. An iron that is too small will require excessive time to heat the work and may never heat it properly. A low-wattage (25-100 W) iron works best for wiring repairs.

Soldering Iron

A soldering iron or soldering gun is used to melt solder. The solder is like an electrical weld holding both sections together.

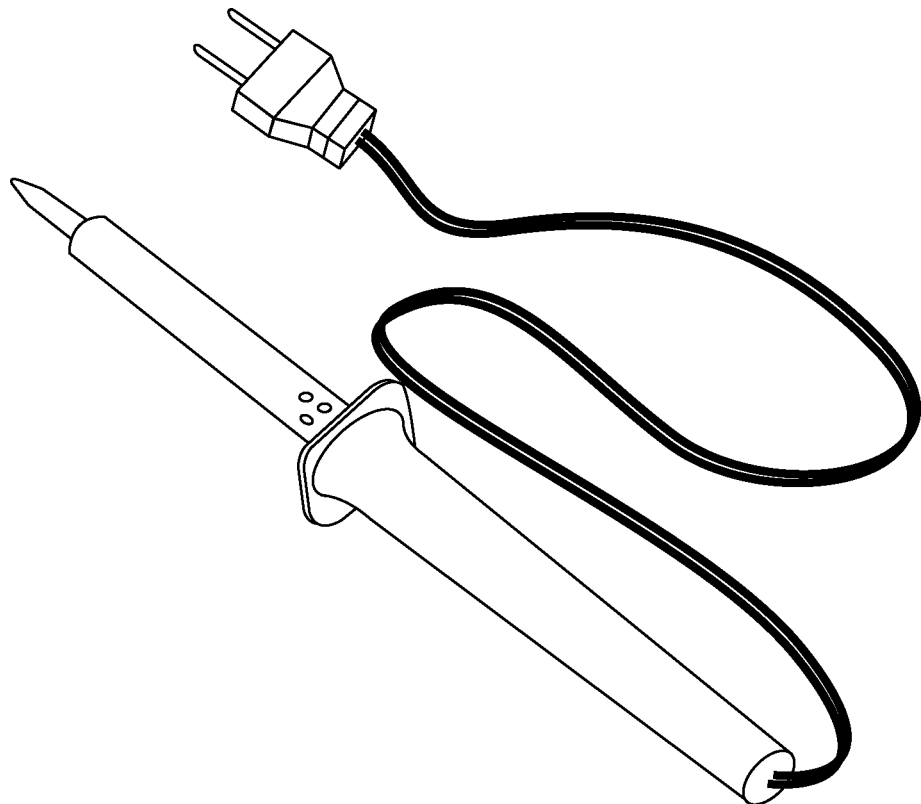

Fig. 2-42
TL623f242

Cleaning Work All traces of paint, rust, grease, and scale must be removed. **Good soldering requires clean, tight splices.**

Tinning the Iron The soldering iron tip is made of copper. Through the solvent action of solder and prolonged heating, it will pit and corrode. An oxidized or corroded tip will not satisfactorily transfer heat from the iron to the work. It should be cleaned and tinned. Use a file and dress the tip down to the bare copper. File the surfaces smooth and flat.

Then, plug the iron in. When the tip color begins to change to brown and light purple, dip the tip in and out of a can of soldering flux (rosin type). Quickly apply rosin core wire solder to all surfaces.

The iron must be at operating temperature to tin properly. When the iron is at the proper temperature, solder will melt quickly and flow freely. **Never try to solder until the iron is properly tinned.**

Soldering Iron Tip

The soldering iron tip must be in good condition for creation of a good solder joint. Tin the tip with a thin layer of solder before soldering wires together.

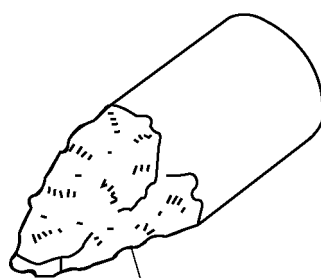

Tip Badly Corroded

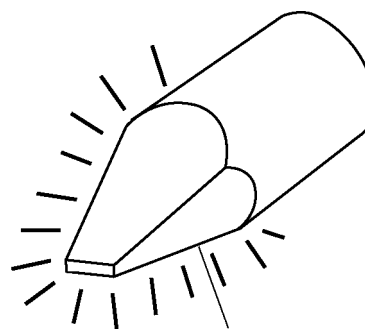

Filed Clean and Smooth

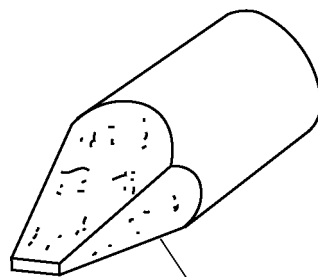

Poor Tinning Job

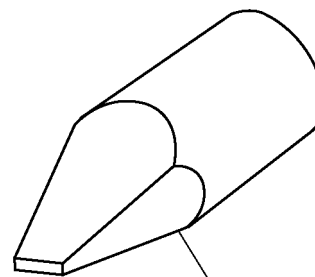

Correctly Tinned

Fig. 2-43
TL623f243

Soldering Wire Splices

Apply the tip flat against the splice. Apply rosin-core wire solder to the flat of the iron where it contacts the splice. As the wire heats, the solder will flow through the splice.

Rules for Good Soldering

1. Clean wires.
2. Wires should be crimped together.
3. Iron must be the right size and must be hot.
4. Iron tip must be tinned.
5. Apply full surface of soldering tip to the splice.
6. Heat wires until solder flows readily.
7. Use rosin-core solder.
8. Apply enough solder to form a secure splice.
9. Do not move splice until solder sets.
10. Place hot iron in a stand or on a protective pad.
11. Unplug iron as soon as you are finished.

Soldering Wires

Heat the wire with the soldering iron. Apply a thin layer of rosin-core solder so it flows into the wiring and forms a strong, conductive bond.

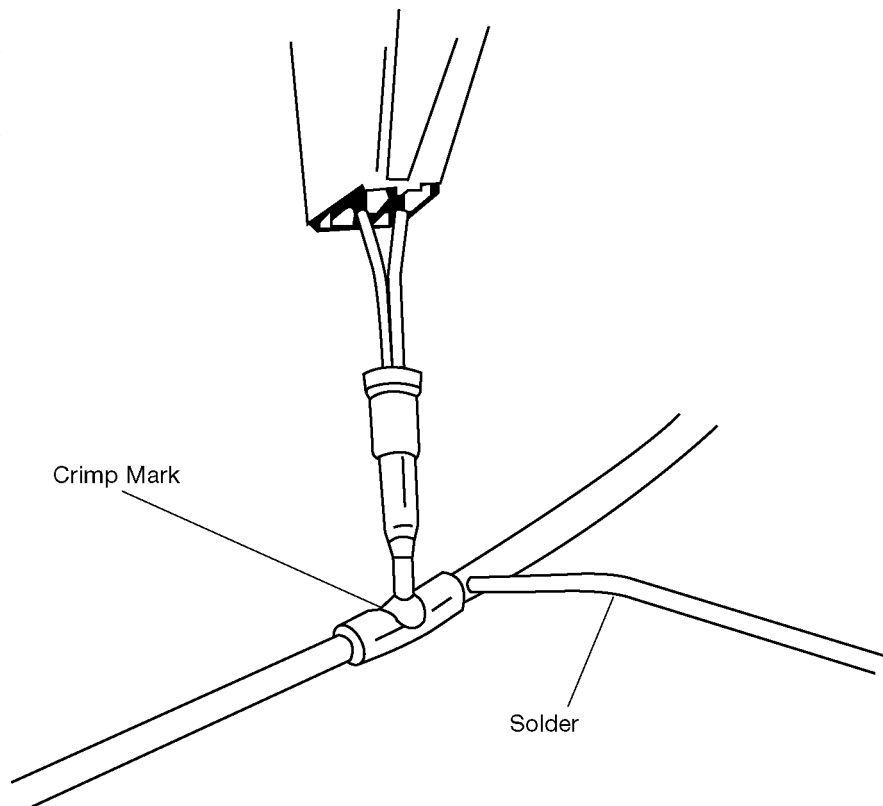

Fig. 2-44
TL623f244

Terminal Replacement

These steps must be followed when replacing a terminal.

Terminal Replacement

Terminal repair requires you follow these steps for a proper repair.

Step 1. Identify the connector and the terminal type.



Step 2. Remove the terminal from the connector.



Step 3. Replace the terminal.



Step 4. Install the terminal into the connector.

Fig. 2-45
TL623f245

Step 1. Identify the connector and terminal type.

1. Replacing Terminals

- a) Identify the connector name, position of the locking clips, the unlocking direction and terminal type from the pictures provided on the charts.

Identify the Connector and Terminal

Many different types of connectors and related terminals are used. A successful repair depends on identifying the correct part required.

The diagram illustrates various electrical connectors and terminals. It features a 3x2 grid of different connector types. A callout on the right shows a close-up of a terminal with a locking clip, labeled with the part number P/N 82998-12170. The caption at the bottom right identifies the figure as Fig. 2-46 TL623f246.

Step 2. Remove the terminal from the connector.

1. Disengage the secondary locking device or terminal retainer.
 - a) Locking device must be disengaged before the terminal locking clip can be released and the terminal removed from the connector.
 - b) Use a miniature screwdriver or the terminal pick to unlock the secondary locking device.

Terminal Lock

Open the lock on the terminal using an appropriate tool.

Example:
(A Type)

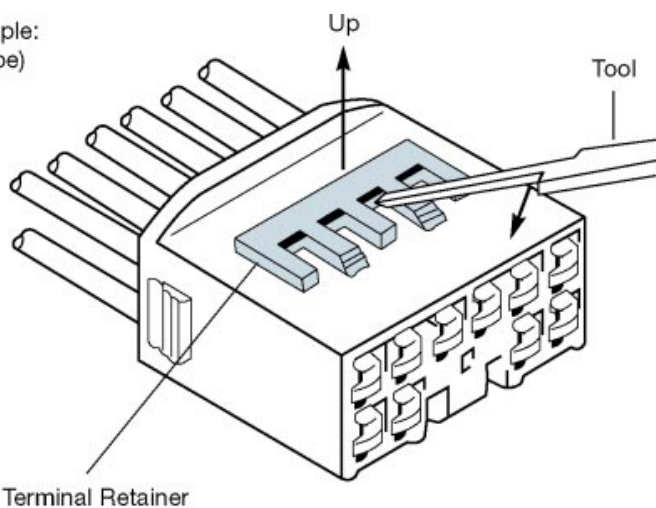

(B Type)

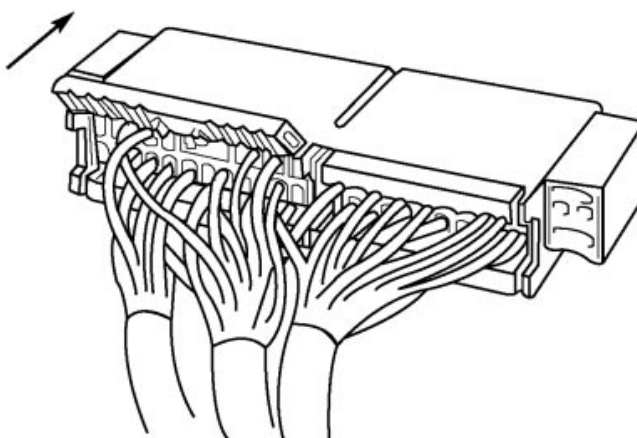

Fig. 2-47
TL623f247

2. Determine the primary locking system from the charts.
 - a) Lock located on terminal
 - b) Lock located on connector
 - c) Type of tool needed to unlock
 - d) Method of entry and operation

Terminal Locks

Use the appropriate tool to depress the terminal lock so you can remove it from the connector.

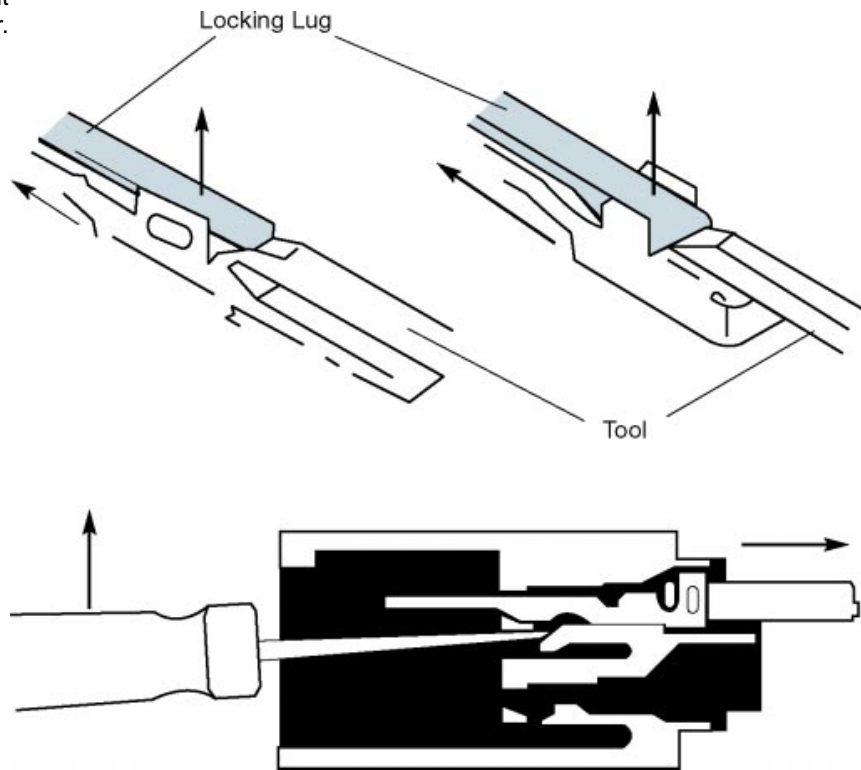

Fig. 2-48
TL623f248

3. Remove terminal from connector by releasing the locking clip.
 - a) Push the terminal gently into the connector and hold it in this position.

Terminal Removal

Push in on the wire to release an tension against the terminal lock.

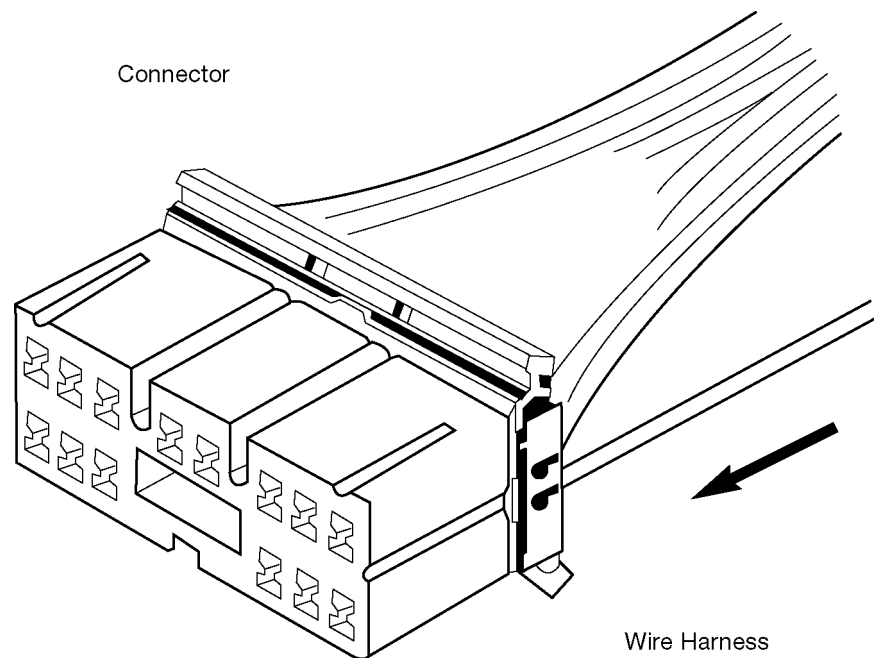

Fig. 2-49
TL623f249

- b) Insert the terminal pick into the connector in the direction shown in the chart.
- c) Move the locking clip to the unlock position and hold it there.

NOTE

Do not apply excessive force to the terminal. Do not pry on the terminal with the pick.

- d) Carefully withdraw the terminal from the connector by pulling the lead toward the rear of the connector.

NOTE

Do not use too much force. If the terminal does not come out easily, repeat steps a) through d).

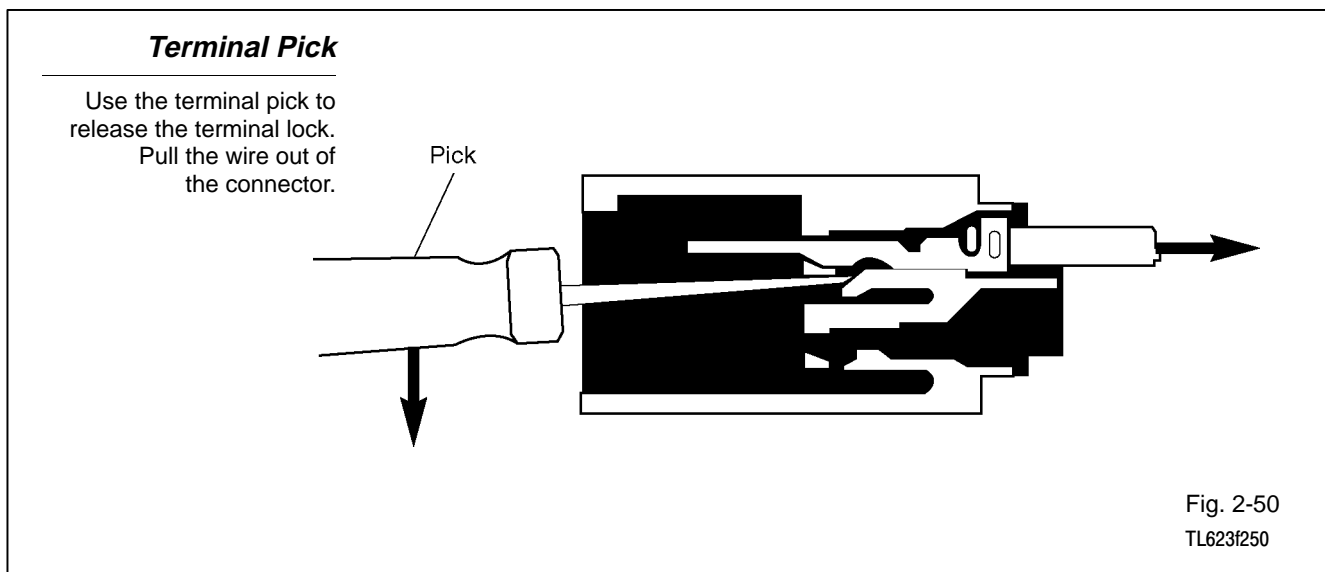

4. Measure “nominal” size of the wire lead by placing a measuring device, such as a micrometer or Vernier Caliper, across the diameter of the insulation on the lead and taking a reading.

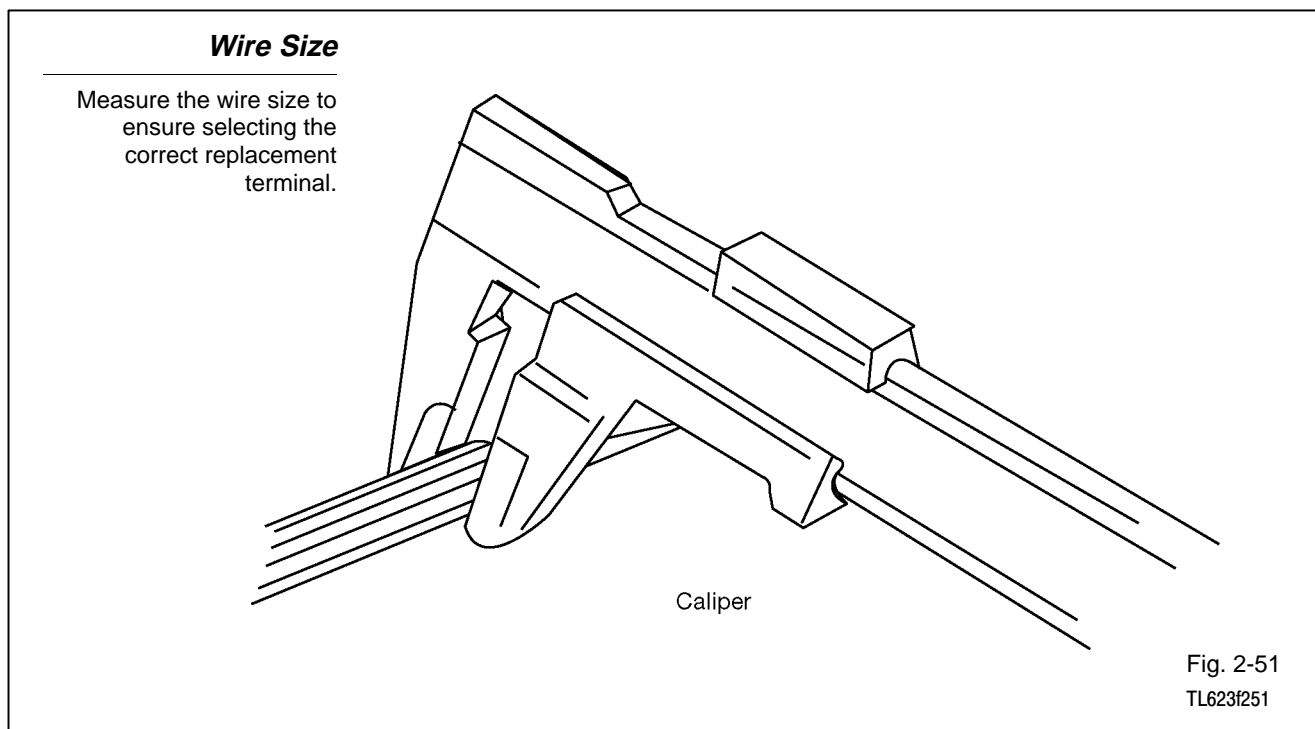

5. Select the correct replacement terminal, with lead, from the repair kit.

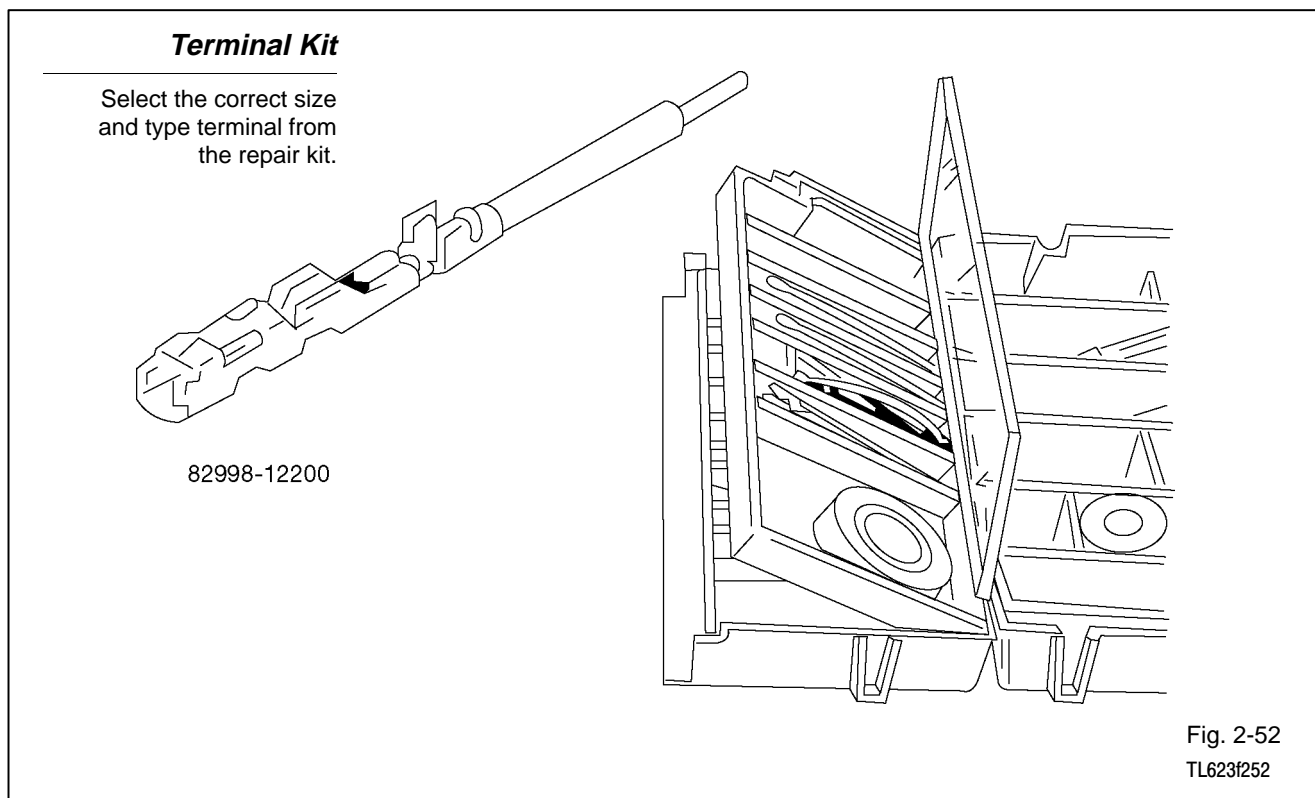

6. Cut the old terminal from the harness.
 - a) Use the new wire lead as a guide for proper length.

NOTE If the length of wire removed is not approximately the same length as the new piece, the following problems may develop:

Too short - tension on the terminal, splice, or the connector, causing an open circuit.

Too long - excessive wire near the connector, may get pinched or abraded, causing a short circuit.

NOTE If the connector is of a waterproof type, the rubber plug may be reused.

Terminal Replacement

Remove the damaged terminal and wire from the harness and replace with a new wire cut to the same length. Too much or too little length can cause future problems.

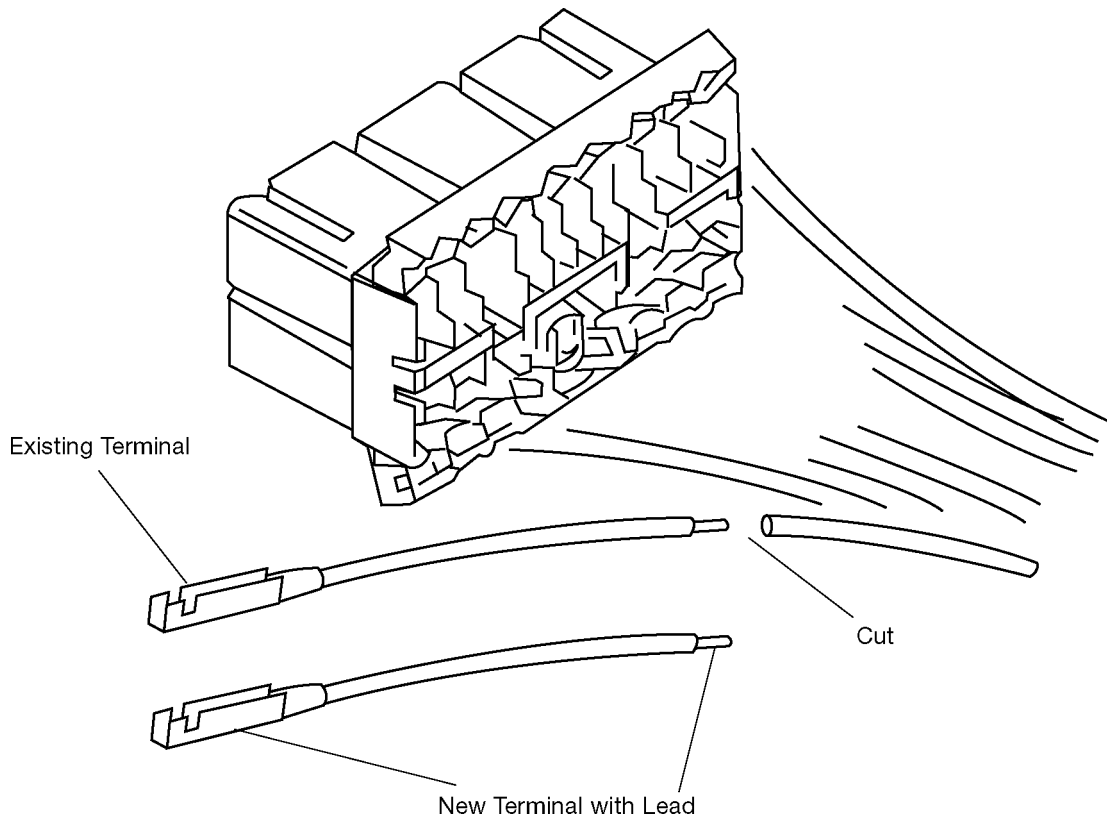
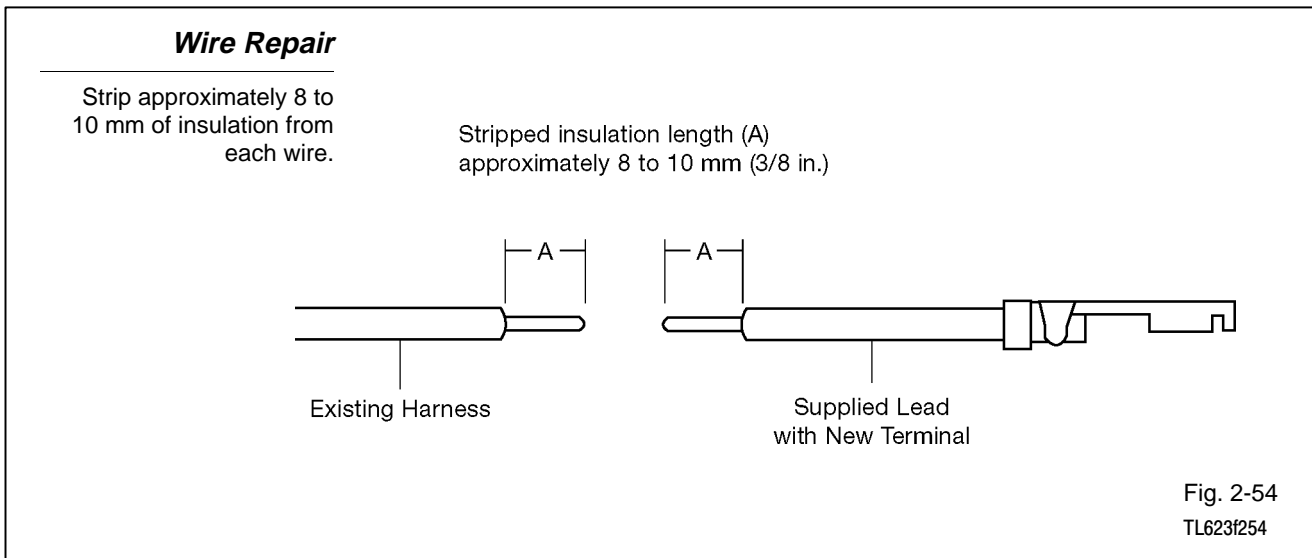

Fig. 2-53
TL623f253

7. Strip insulation from wire on the harness and replacement terminal lead.
 - a) Strip length should be approximately 8 to 10 mm ($\frac{3}{8}$ in.).

NOTE

Strip carefully to avoid nicking or cutting any of the strands of wire.



NOTE

If heat shrink tube is to be used, it must be installed at this time, sliding it over the end of one wire to be spliced. (See Step 3, 4. B. 1. for instructions on how to use heat shrink tube.)

NOTE

If the connector is a waterproof type, the rubber plug should be installed on the terminal end at this time.

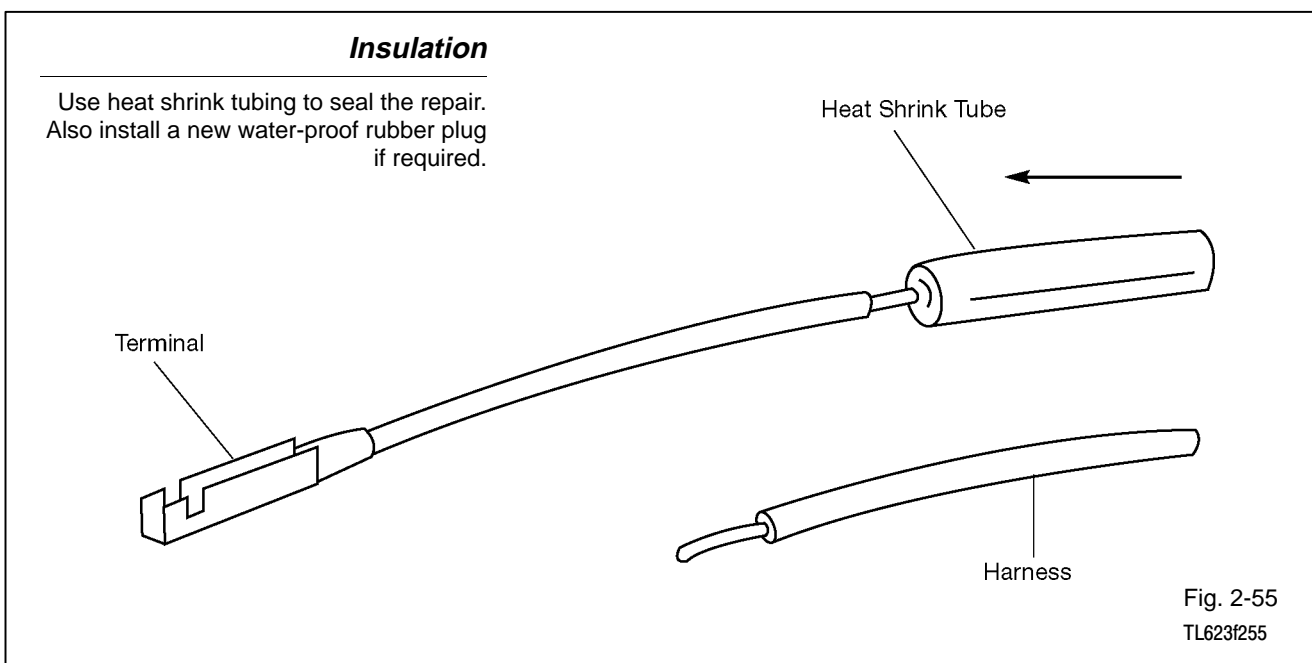

Step 3. Replace the terminal.

1. Select correct size of splice from the repair kit.
 - a) Size is based on the nominal size of the wire (three sizes are available).

	<u>Part Number</u>	<u>Wire Size</u>
Small	00204-34130	16-22 AWG 1.0 - 0.2 mm
Medium	00204-34137	14-16 AWG 2.0 - 1.0 mm
Large	00204-34138	10-12 AWG 5.0 - 3.0 mm

Splices

Select the appropriate size splice for the wire repair from the repair kit.

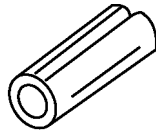

Small: 00204-34130

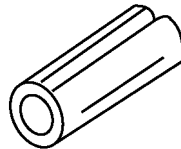

Medium: 00204-34137

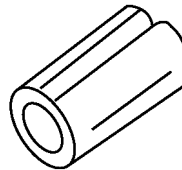

Large: 00204-34138

Fig. 2-56
TL623f256

2. Crimp the replacement terminal lead to the harness lead.
 - a) Insert the stripped ends of both the replacement lead and the harness lead into the splice, overlapping the wires inside the splice.

NOTE Do not place insulation in the splice, only stripped wire.

Using the Splice

Place both wires into the splice. Do not place the insulated portion in the splice.

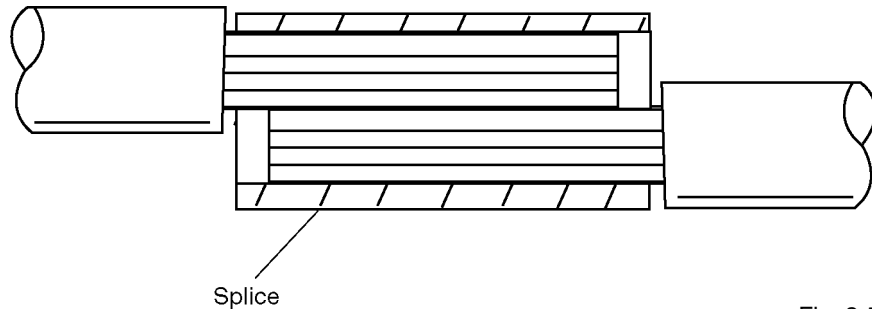

Fig. 2-57-1
TL623f257-1

- b) Do not use position marked "INS."
 - (1) The crimping tool has positions marked for insulated splices (marked "INS") that should not be used, as they will not crimp the splice tightly onto the wires.

Crimp the Splice

Crimp the splice using the appropriate tool. Do not use the insulated (INS) portion of the tool.

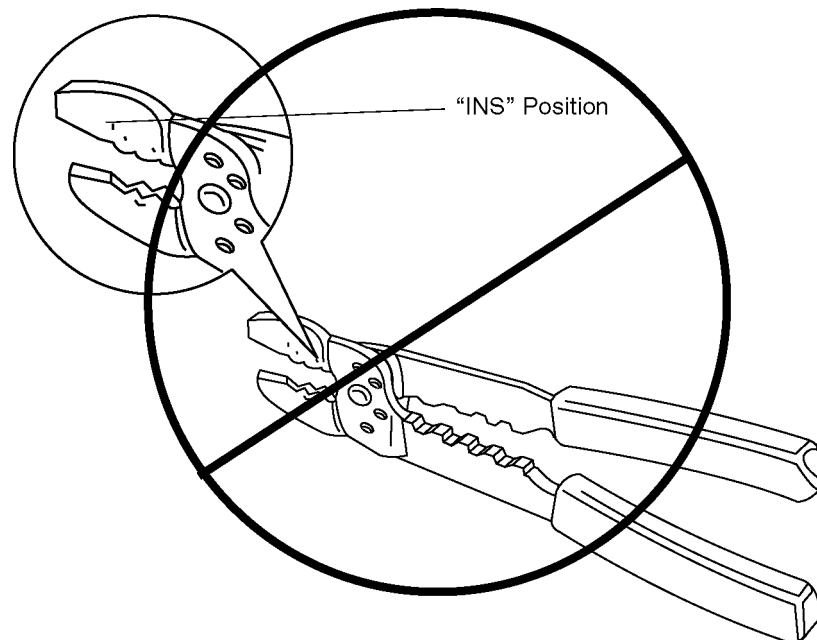

Fig. 2-57-2
TL623f257-2

c) Use only position marked "NON INS."

- (1) With the center of the splice correctly placed between the crimping jaws, squeeze the crimping tool together until the contact points of the crimper come together.

NOTE Make sure the wires and the splice are still in the proper position before closing the crimping tool ends. Use steady pressure in making the crimp.

- (2) Make certain that the splice is crimped tightly.

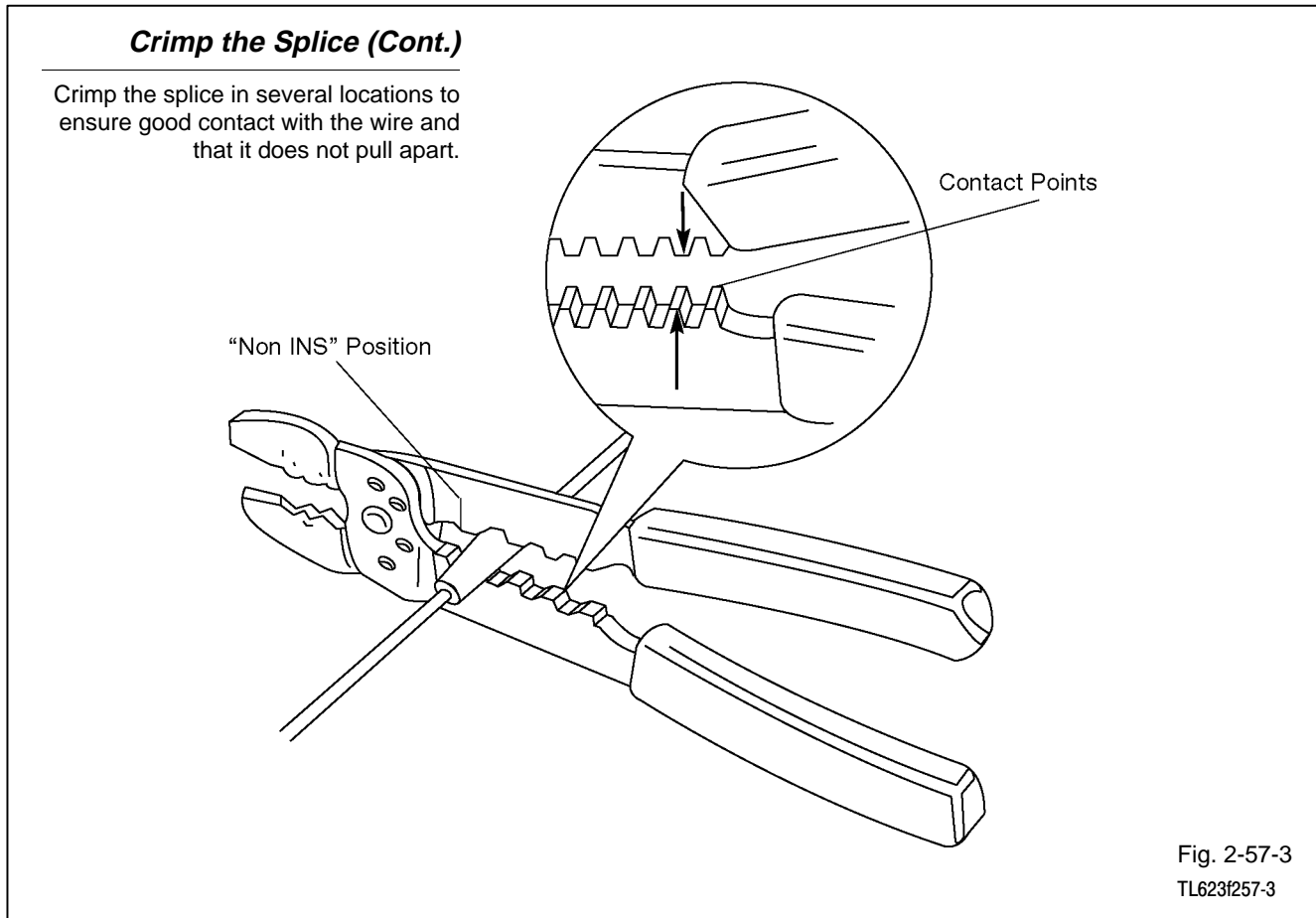

3. Solder the completed splice using **only** rosin core solder.
 - a) Wires and splices **must** be clean.
 - b) A good mechanical joint **must** exist, because the solder will not hold the joint together.
 - c) Heat the joint with the soldering iron until the solder melts when pressed onto the joint.
 - d) Slowly press the solder into the hot splice on one end until it flows into the joint and out the other end of the splice.

NOTE Do not use more solder than necessary to achieve a good connection. There should not be a “glob” of solder on the splice.

- e) When enough solder has been applied, remove the solder from the joint and then remove the soldering iron.

Solder the Splice

Solder the splice using rosin-core solder.

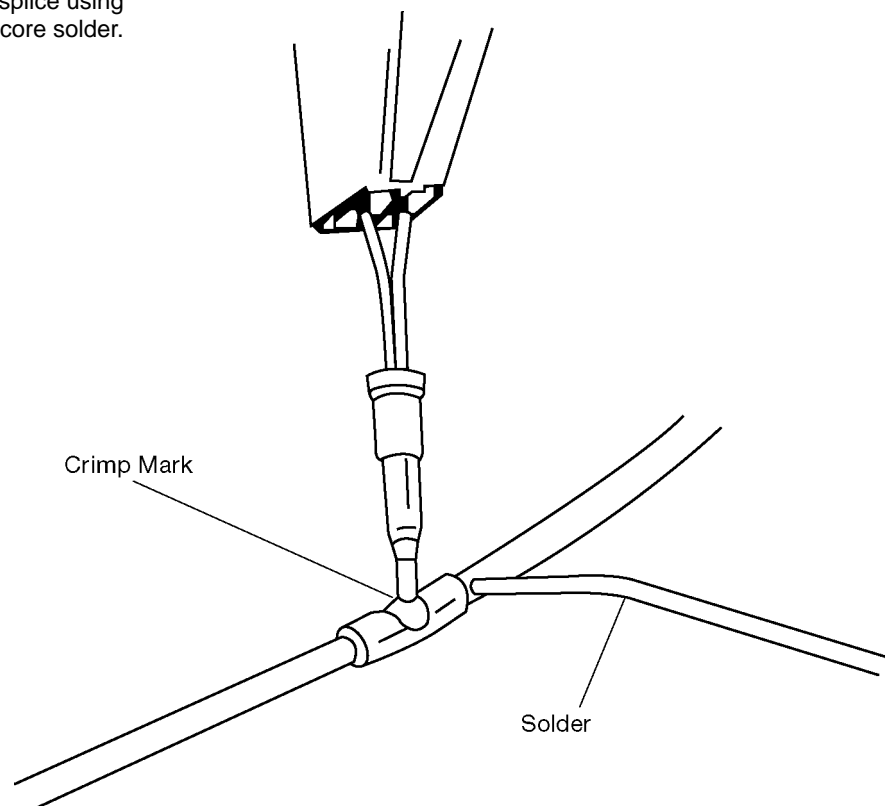

Fig. 2-58
TL623f258

4. Insulate the soldered splice using one of the following methods:
 - a) Silicon tape (provided in the wire repair kit).
 - (1) Cut a piece of tape from the roll approximately 25 mm (1 in.) long.
 - (2) Remove the clear wrapper from the tape.

NOTE The tape will not feel “sticky” on either side.

- (3) Place one end of the tape on the wire and wrap the tape tightly around the wire. You should cover one-half of the previous wrap each time you make a complete turn around the wire. (When stretched, this tape will adhere to itself.)
- (4) When completed, the splice should be completely covered with the tape and the tape should stay in place. If both of these conditions are not met, remove the tape and repeat steps 1 through 4.

NOTE If the splice is in the engine compartment or under the floor, or in an area where there might be abrasion on the spliced area, cover the silicon tape with vinyl tape.

Splice Insulation

Insulate with shrink tubing and/or silicon tape. Cover with vinyl tape also if the wiring is in a high abrasion area.

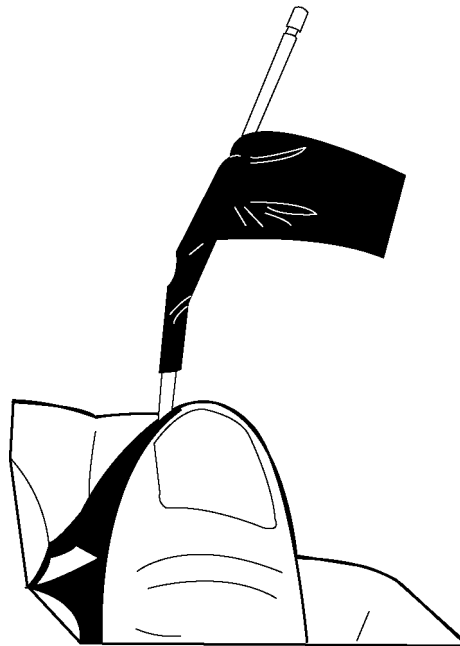
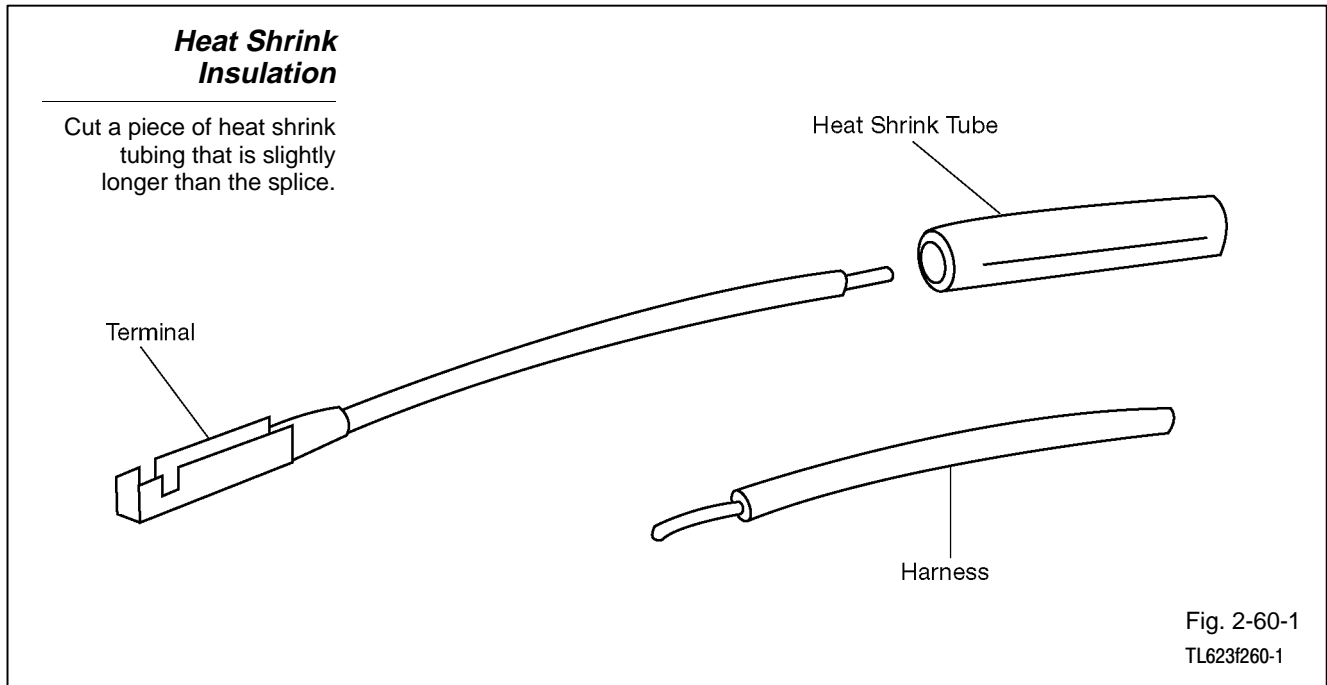

Fig. 2-59
TL623f259

- b) Apply heat shrink tube (provided in the wire repair kit).
- (1) Cut a piece of the heat shrink tube that is slightly longer than the splice, and slightly larger in diameter than the splice.



- (2) Slide the tube over the end of one wire to be spliced. (**THIS STEP MUST BE DONE PRIOR TO JOINING THE WIRES TOGETHER!**)
- (3) Center the tube over the soldered splice.
- (4) Using a source of heat, such as a heat gun, gently heat the tubing until it has shrunk tightly around the splice.

NOTE Do not continue heating the tubing after it has shrunk around the splice. It will only shrink a certain amount, and then stop. It will not continue to shrink as long as you hold heat to it, so be careful not to melt the insulation on the adjoining wires by trying to get the tubing to shrink further.

***Heat Shrink
Insulation (Cont.)***

Use a heat gun to shrink the tubing over the repair/splice.

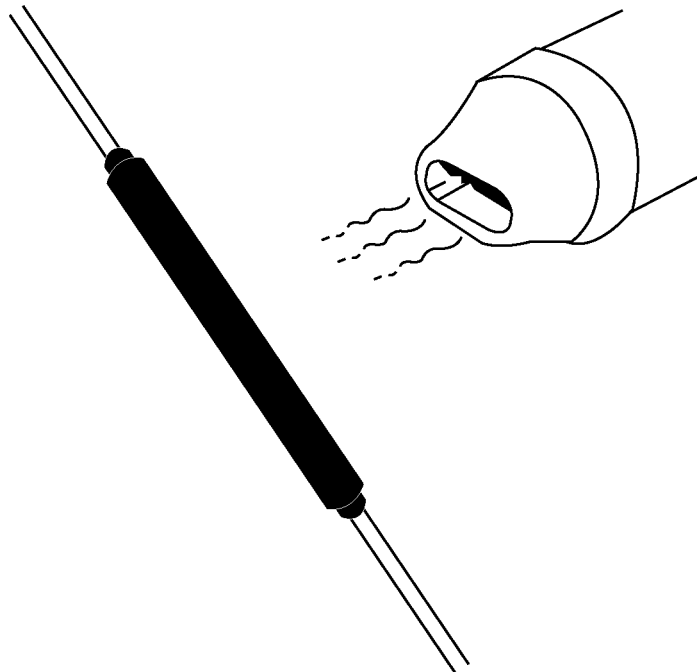
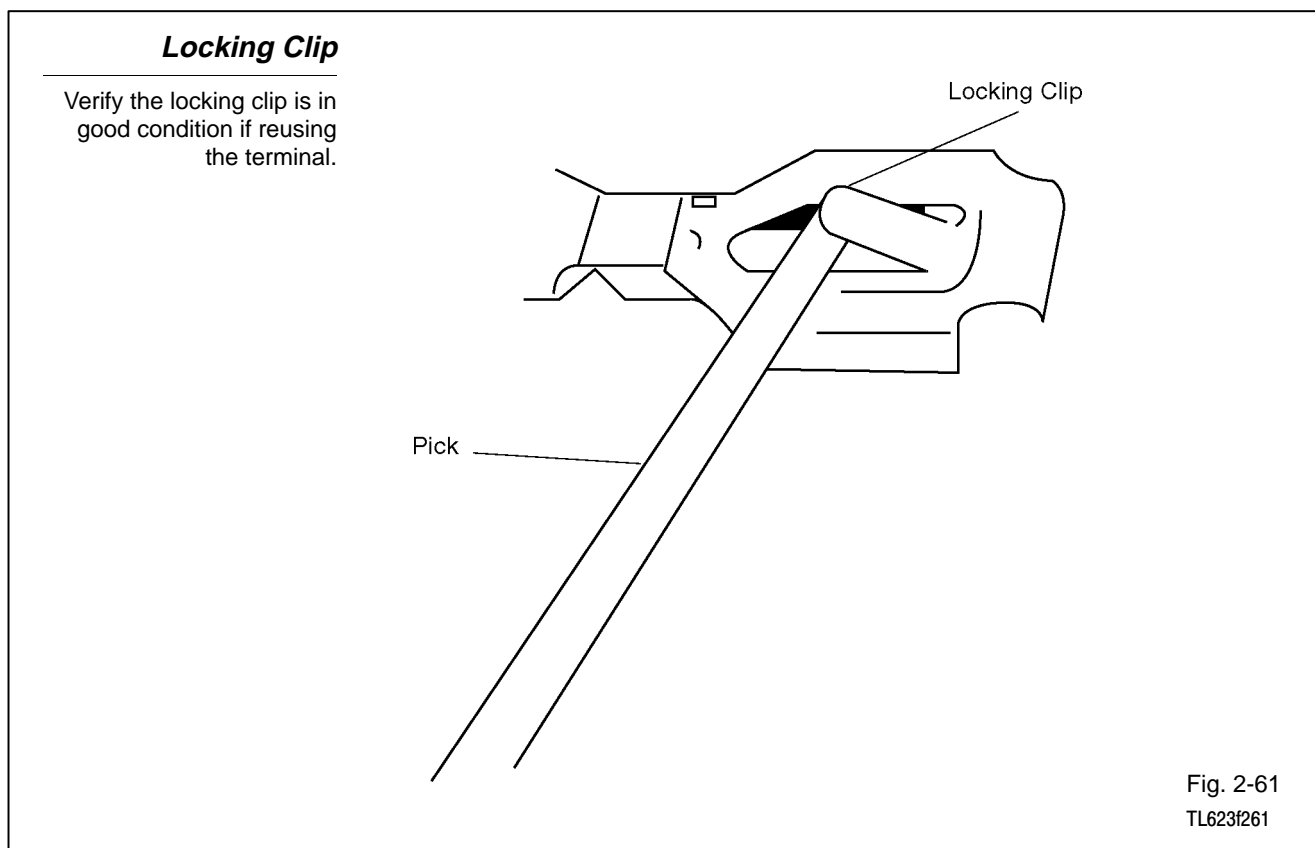

Fig. 2-60-2
TL623f260-2

Step 4. Install the terminal into the connector.

1. If reusing a terminal, check that the locking clip is still in good condition and in the proper position.
 - a. If it is on the terminal and not in the proper position, use the terminal pick to gently bend the locking clip back to the original shape.
 - b. Check that the other parts of the terminal are in their original shape.



2. Push the terminal into the connector until you hear a “click.”

NOTE Not all terminals will give an audible “click.”

Terminal Insertion

Insert the terminal into the connector until you hear a click as it locks into place.

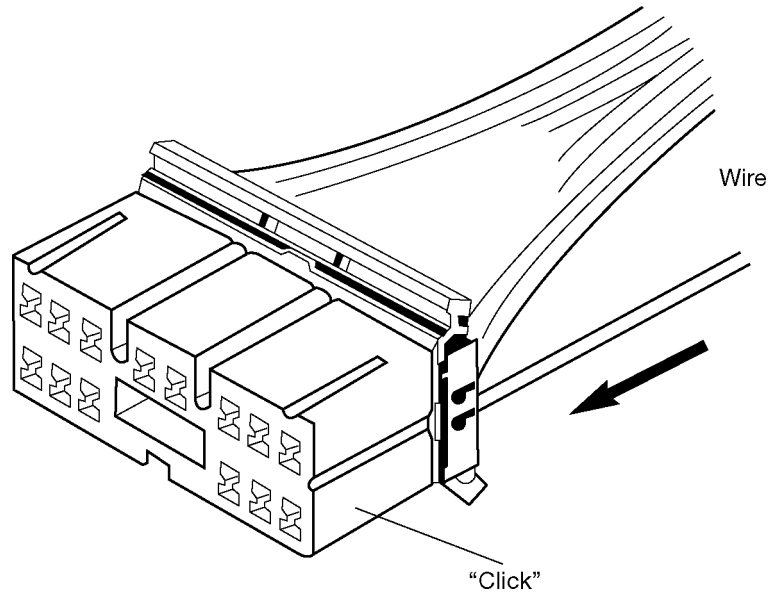

Fig. 2-62
TL623f262

- a) When properly installed, pulling gently on the wire lead will prove the terminal is locked in the connector.

Verify Terminal is Locked

Gently pull on the wire to verify the terminal has locked into the connector. Reinsert and recheck if required.

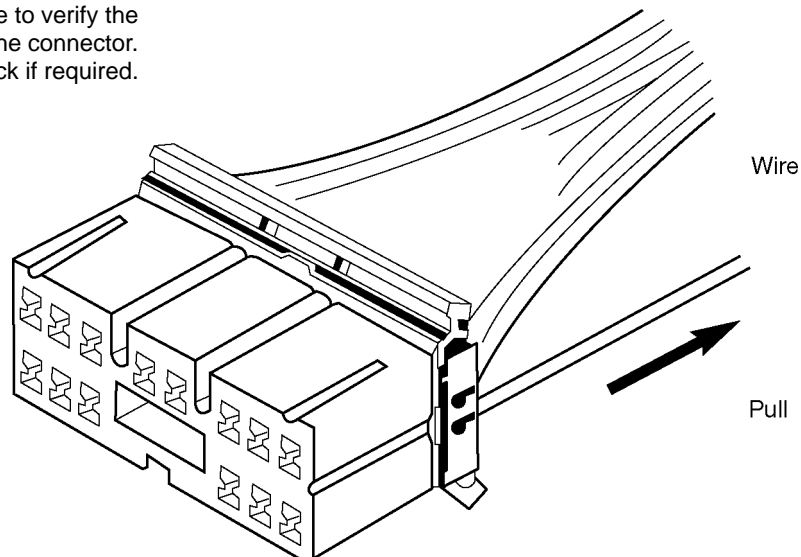
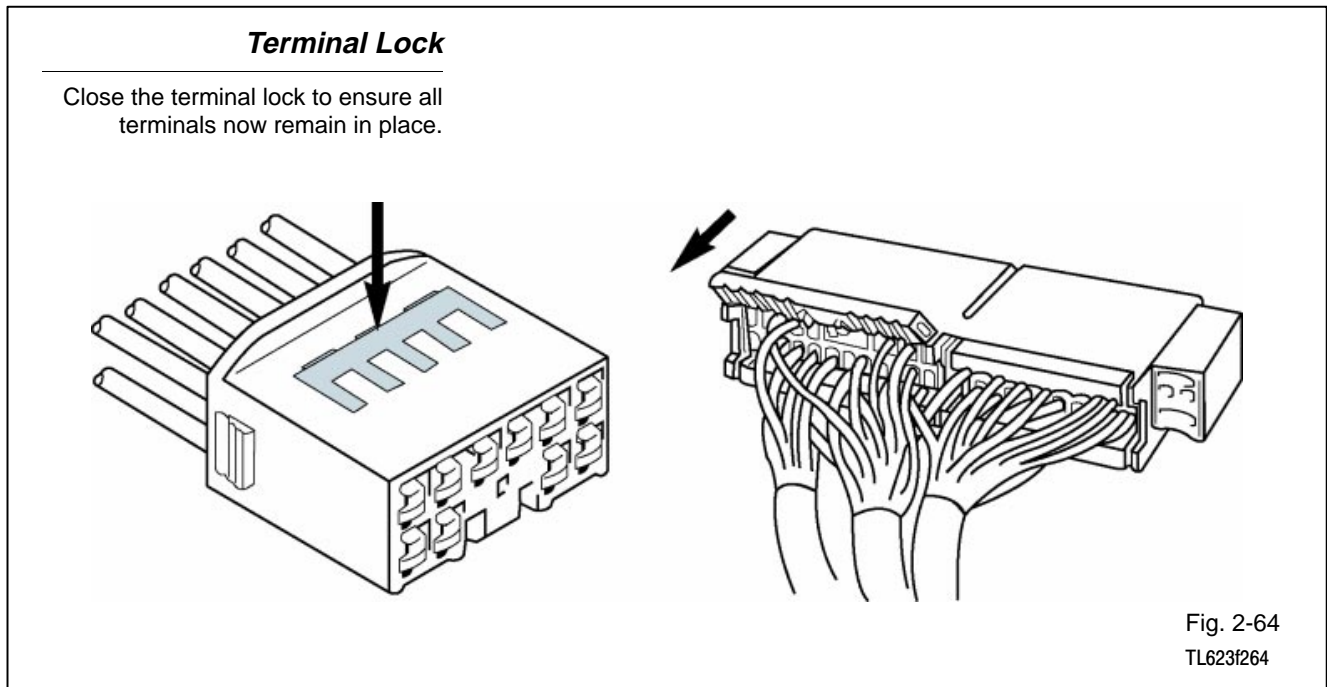
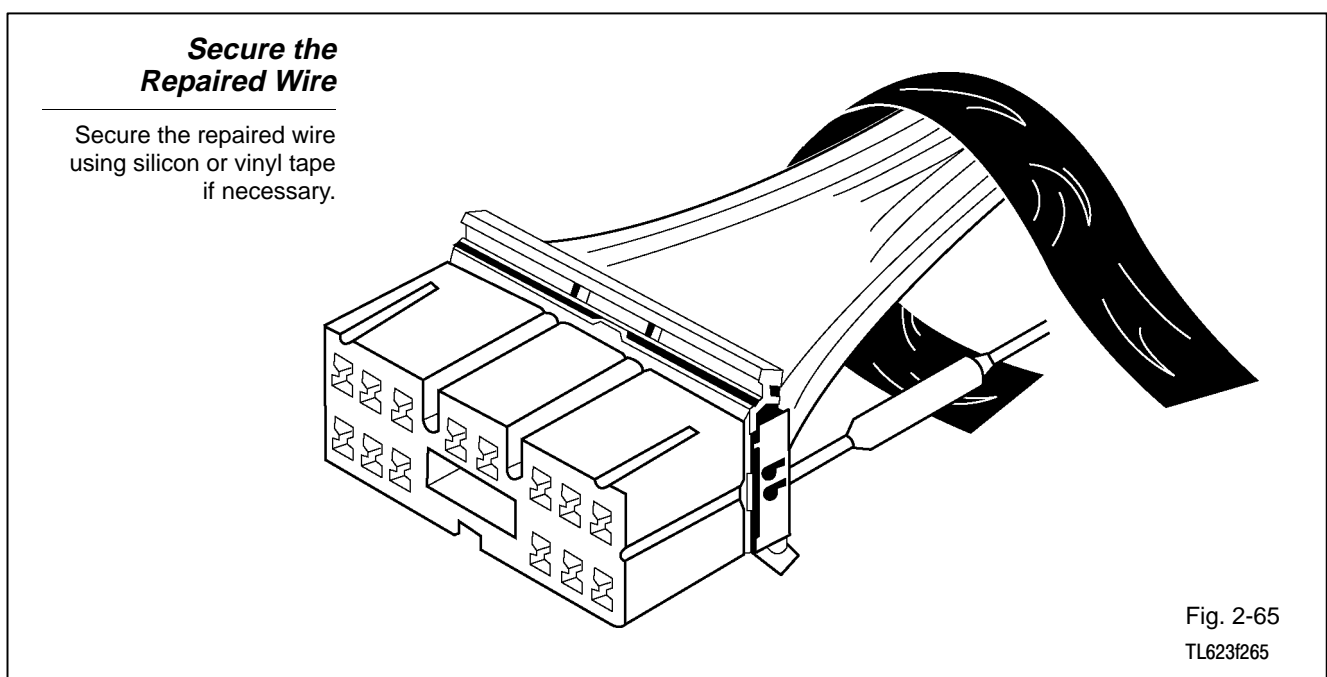

Fig. 2-63
TL623f263

3. Close terminal retainer or secondary locking device.
 - a) If the connector is fitted with a terminal retainer, or a secondary locking device, return it to the lock position.



4. Secure the repaired wire to the harness.
 - a) If the wire is not in the conduit, or secured by other means, wrap vinyl tape around the bundle to keep it together with the other wires.





Notes



WORKSHEET 2-1

Series circuits

Worksheet Objectives

With this worksheet you will assemble series circuits. When you have completed this worksheet, you will have demonstrated use of the DMM to measure voltage, current, and resistance in a series circuit.

Tools and Equipment

For this exercise you will need the following:

- Electrical simulator
- Digital multimeter

Complete the related activities outlined in each step which include:

- Assembling the circuit as shown for each worksheet section.
- Use the DMM to take voltage, amperage, and resistance measurements.
- Answer the related questions.



Stop your work when you see the  sign. You will review your work with the instructor before continuing to the next section.

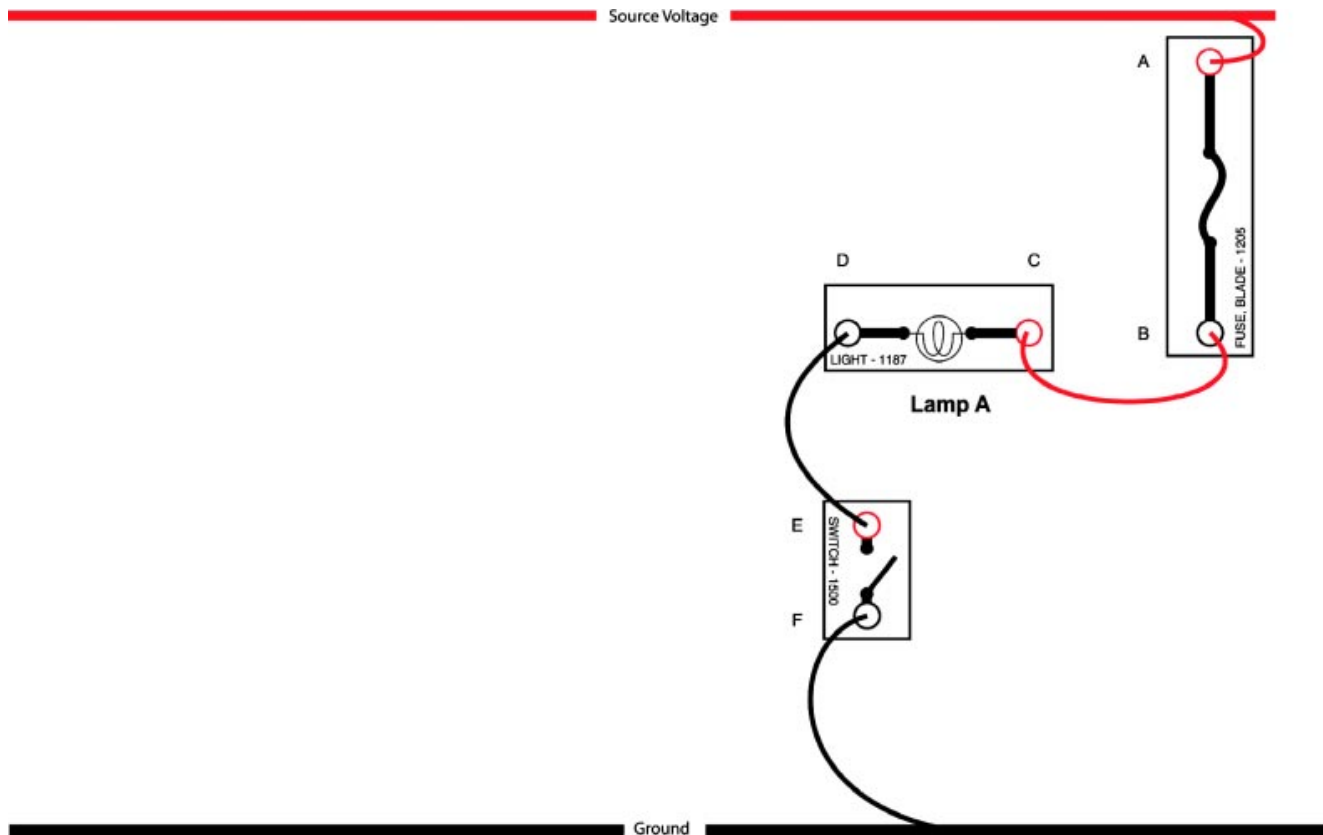

Fig. 2W1-1
TL623f001c-2W1

1. Build the circuit shown above on the electrical simulator.
2. Set up your DMM to measure the voltage in this circuit:
 - Mode selector to DC volts
 - Auto-range on
 - Black lead plugged into COM input jack
 - Red lead plugged into Volt/Ohm/Diode input jack
3. Turn on the electrical simulator power supply and close the switch (lamp should come on).

Series Circuits

4. Predict the available voltage at the test points indicated:

A. _____

B. _____

C. _____

D. _____

E. _____

F. _____

5. Measure available voltage using the DMM. Place the black lead on the circuit ground point. Place the red lead at each test point and note the readings in the spaces below.

A. _____

B. _____

C. _____

D. _____

E. _____

F. _____

Note: Ask your instructor if you are unsure why the actual voltage was different from what you predicted.

Exercise 2: Measuring Voltage drops in series circuits

6. Measure the voltage drop in the circuit as follows: Place the red lead on the most positive side of the circuit component and the black lead on the most negative (ground) side of the circuit component (example: red lead on A, black lead on B). Measure the voltage drops through each of the circuit components:

A. Source: _____ (Measure from power supply to fuse location A.)

B. Fuse: _____

C. Lamp: _____

D. Switch: _____

E. Ground: _____ (Measure from switch ground point F to power supply.)

Exercise 3: Measuring Amperage in series circuits

7. Measure circuit amperage as follows:

- Turn off the power supply.
- Set the DMM to amperage and move the red lead to the 10 Amp jack.
- Open the circuit at point A and connect the red lead to the wire and the black lead to the fuse point A.
- Turn the power supply on.
- What is the amperage? _____ (Note: You can use the 200mA scale for a more exact reading if the initial reading is less than 200mA. Move the dial and change the red lead to the mA jack.)
- Measure amperage at test point E. _____ Was the amperage the same?

YES / NO (circle one)

If yes, why?



Stop here after completing all the related activities and answering the questions. Inform your instructor that you are ready to review this section.

Exercise 4: Series circuits with more than one load

8. Turn off the circuit. Add another 1187 lamp to the circuit as shown. Turn on the circuit.

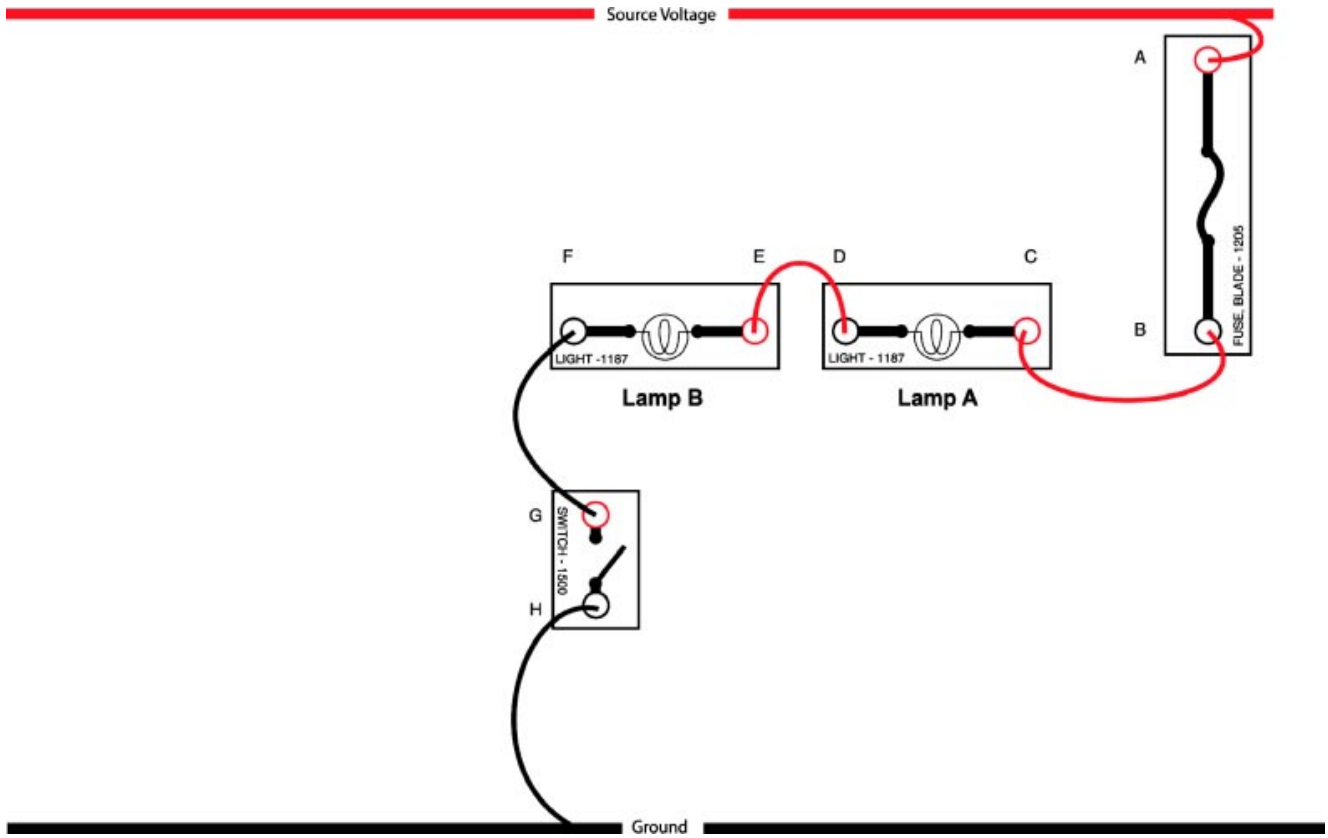

Fig. 2W1-2
TL623f002c-2W1

Did the brightness of the first lamp change? YES / NO (circle one)

If YES, explain why?

9. Predict and measure the available voltage in the circuit at each of the test points: (Caution: Change the red lead back to the Voltage position on the DMM and reset the dial to voltage before testing.)

Predicted Voltage	Available Voltage
A. _____	A. _____
B. _____	B. _____
C. _____	C. _____
D. _____	D. _____
E. _____	E. _____
F. _____	F. _____
G. _____	G. _____
H. _____	H. _____

Note: Ask your instructor for assistance if you unsure why the actual voltage was different from what you predicted.

10. Measure the voltage drop in the circuit at the following locations.

- A. Source (wire): _____
- B. Fuse: _____
- C. Lamp A: _____
- D. Lamp B: _____
- E. Switch: _____
- F. Ground (wire): _____

11. Measure Amperage in the circuit.

12. Measure the resistance of lamp A _____ , Lamp B _____ .

13. Measure total circuit resistance (Disconnect the ground lead from the power supply): _____

14. Add the resistance of lamp A and B together: _____

Do they equal total circuit resistance? YES / NO (circle one)

Why? _____



Stop here after completing all the related activities and answering the questions. Inform your instructor that you are ready to review this section.

Series Circuits

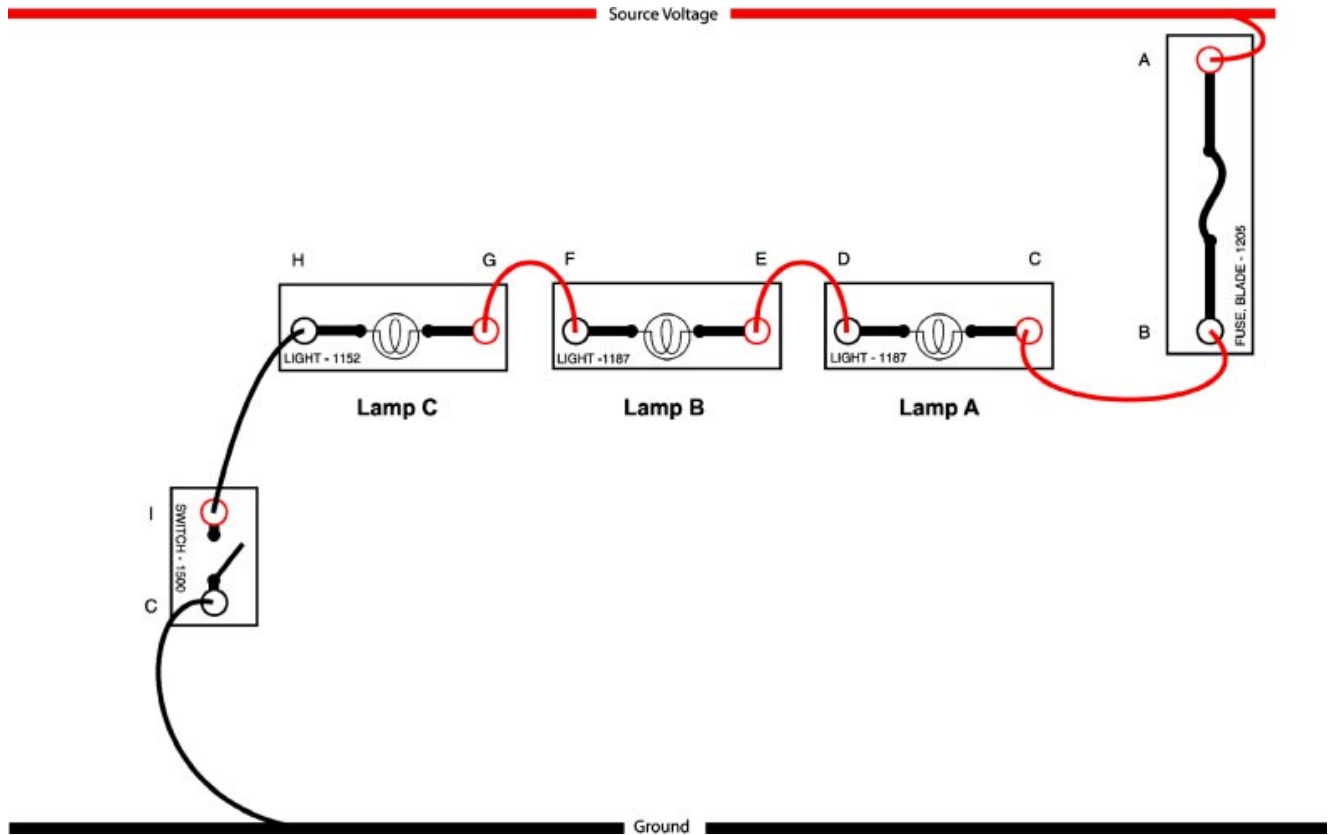

Fig. 2W1-3
TL623f003c-2W1

15. Turn the power supply off. Add lamp 1152 in the circuit as shown. Turn the power supply on.

What do you notice about the lamps?

Why? _____

16. Measure the voltage drop across each of the lamps:

Lamp A: _____

Lamp B: _____

Lamp C: _____

Add the voltage drop for each lamp together: _____

Does the total equal source voltage? YES / NO (circle one)

17. Measure the resistance of the lamps as follows:

- Turn the power supply off.
- Set the DMM to measure resistance.
- Isolate each lamp by disconnecting each as you measure their resistance (example: Disconnect wires at points C and D to measure the first lamp).

Lamp A: _____

Lamp B: _____

Lamp C: _____

18. Reconnect all the lamps and turn the power supply on. Unscrew the 1152 lamp. Did they all turn off?

YES / NO (circle one)

Why? _____

What voltage would you expect to see at point D? _____

Measure the voltage at point D: _____



Stop here after completing all the related activities and answering the questions. Inform your instructor that you are ready to review this section.

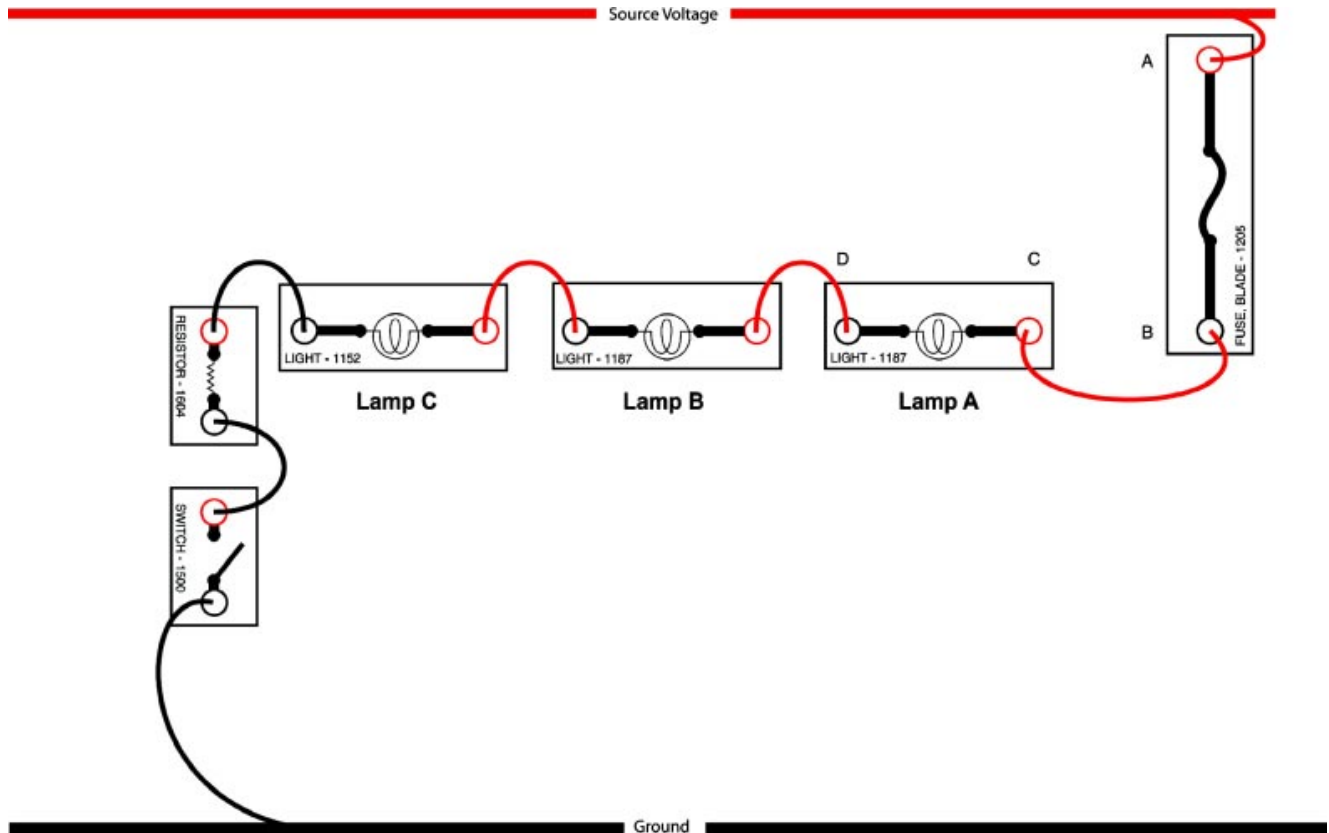

Fig. 2W1-4
TL623f004c-2W1

19. Turn the power supply off. Screw the lamp back in. Add resistor 1604 to the circuit as shown. Turn the power supply on.

Do the bulbs light? YES / NO (circle one)

Is the circuit working? YES / NO (circle one)

Measure voltage drop and amperage in the circuit to verify operation:

Voltage drop Circuit amperage: _____

Lamp A: _____

Lamp B: _____

Lamp C: _____

Resistor: _____

20. Measure total circuit resistance: _____

21. Compared to the circuit with only 2 bulbs (pg. 2W1-5), resistance has [increased/decreased] (circle one) and amperage has [increased/decreased].



Stop here after completing all the related activities and answering the questions. Inform your instructor that you are ready to review this section.

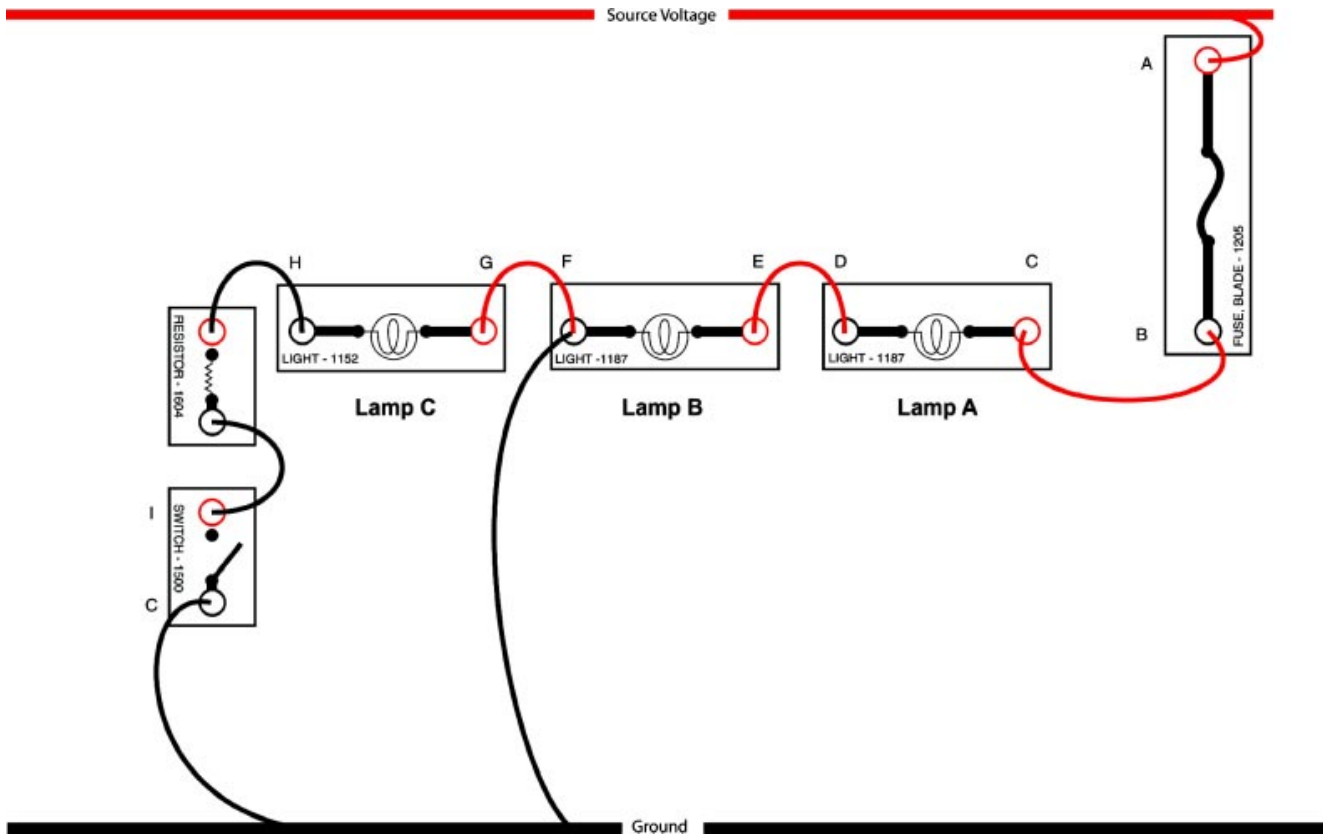

Fig. 2W1-5
TL623f005c-2W1

22. Turn the power supply off. Use a jumper wire to create a short circuit as shown above.

Why did the first two lamps get brighter? _____

Why did the last lamp go out? _____

23. Explain the relationship between Voltage, Amperage and Resistance based on your readings made in this module.

Voltage: _____

Amperage: _____

Resistance: _____

24. Turn off the power supply and the DMM.



Stop here after completing all the related activities and answering the questions. Inform your instructor that you are ready to review this section.

Series Circuits

Name: _____ Date: _____

Review this sheet as you are doing the Series Circuits worksheet. Check each category after viewing the instructor's presentation and completing the worksheet. Ask the instructor if you have questions regarding the topics provided below. Additional space is provided under topic for you to list any other concerns that you would like you instructor to address. The comments section is provided for your personal comments, information, questions, etc.

I have questions

I know I can

Topic			Comment
Predict Available Voltage			
Measure Available Voltage			
Measure Voltage Drop			
Measure Circuit Amperage			
Measure Resistance			



Notes



WORKSHEET 2-2 *Parallel Circuits*

Worksheet Objectives

In this worksheet you will assemble parallel circuits. When you have completed this worksheet, you will have demonstrated use of the DMM to measure voltage, current, and resistance in a parallel circuit.

Tools and Equipment

For this exercise you will need the following:

- Electrical simulator
- Digital multimeter

Complete the related activities outlined in each step which include:

- Assembling the circuit as shown for each worksheet section.
- Use the DMM to take voltage, amperage, and resistance measurements.
- Answer the related questions.



Stop your work when you see the  sign. You will review your work with the instructor before continuing to the next section.

Exercise 1: Available Voltage in Parallel Circuits

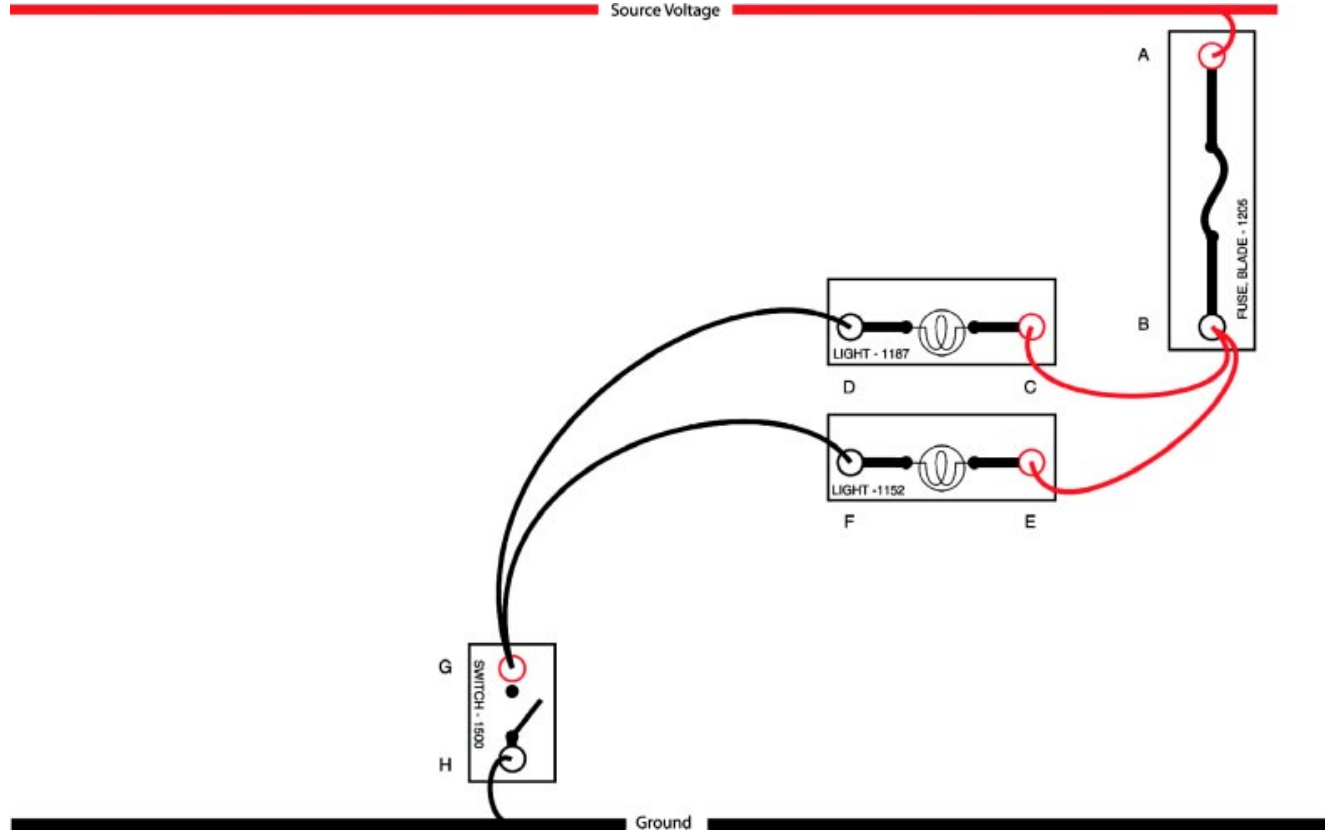

Fig. 2W2-1
TL623f001c-2W2

1. Build the circuit section shown above on the electrical simulator.
2. Set up your DMM to measure the voltage in this circuit:
 - Mode selector to DC volts
 - Auto-range on
 - Black lead plugged into COM input jack
 - Red lead plugged into Volt/Ohm/Diode input jack
3. Turn on the electrical simulator power supply and close the switch (lamps should come on).

Parallel Circuits

4. Predict the available voltage at the test points indicated with the circuit ON:

A. _____

B. _____

C. _____

D. _____

E. _____

F. _____

G. _____

H. _____

5. Measure available voltage using the DMM. Place the black lead on the circuit ground point. Place the red lead at each test point and note the readings in the spaces below.

A. _____

B. _____

C. _____

D. _____

E. _____

F. _____

G. _____

H. _____

Note: Ask your instructor if you are unsure why the actual voltage was different from what you predicted.

6. Measure the voltage drop in the circuit as follows: Place the red lead on the most positive side of the circuit component and the black lead on the most negative (ground) side of the circuit component (example: red lead on A, black lead on B). Measure the voltage drops through each of the circuit components:

A. Source: _____ (Measure from power supply to fuse location A.)

B. Fuse: _____

C. 1187 Lamp: _____

D. 1152 Lamp: _____

D. Switch: _____

E. Ground: _____ (Measure from switch ground point F to power supply.)

7. Measure circuit amperage at the following test points:

A. At the fuse: _____

B. At lamp 1 (branch 1 of the circuit): _____

C. At lamp 2 (branch 2 of the circuit): _____

Add the amperage of branch 1 with branch 2: _____

Does the sum of each branch equal current at the source? YES / NO (circle one)

8. Measure resistance in the circuit as follows:

A. Measure the resistance of each branch (remember to isolate the branch from the rest of the circuit by disconnecting the jumper wire at each end):

Branch 1: _____

Branch 2: _____

Add branch 1 and branch 2 together: _____

B. Reconnect the jumper wires in the circuit. Disconnect the jumper wires from the power supply.

Measure resistance from the source (A) to the ground (H): _____

Does the sum of the branches equal total resistance? YES / NO (circle one)

Why? _____



Stop here after completing all the related activities and answering the questions. Inform your instructor that you are ready to review this section.

Parallel Circuits

9. Add another 1187 bulb to the circuit as shown. Turn on the circuit.

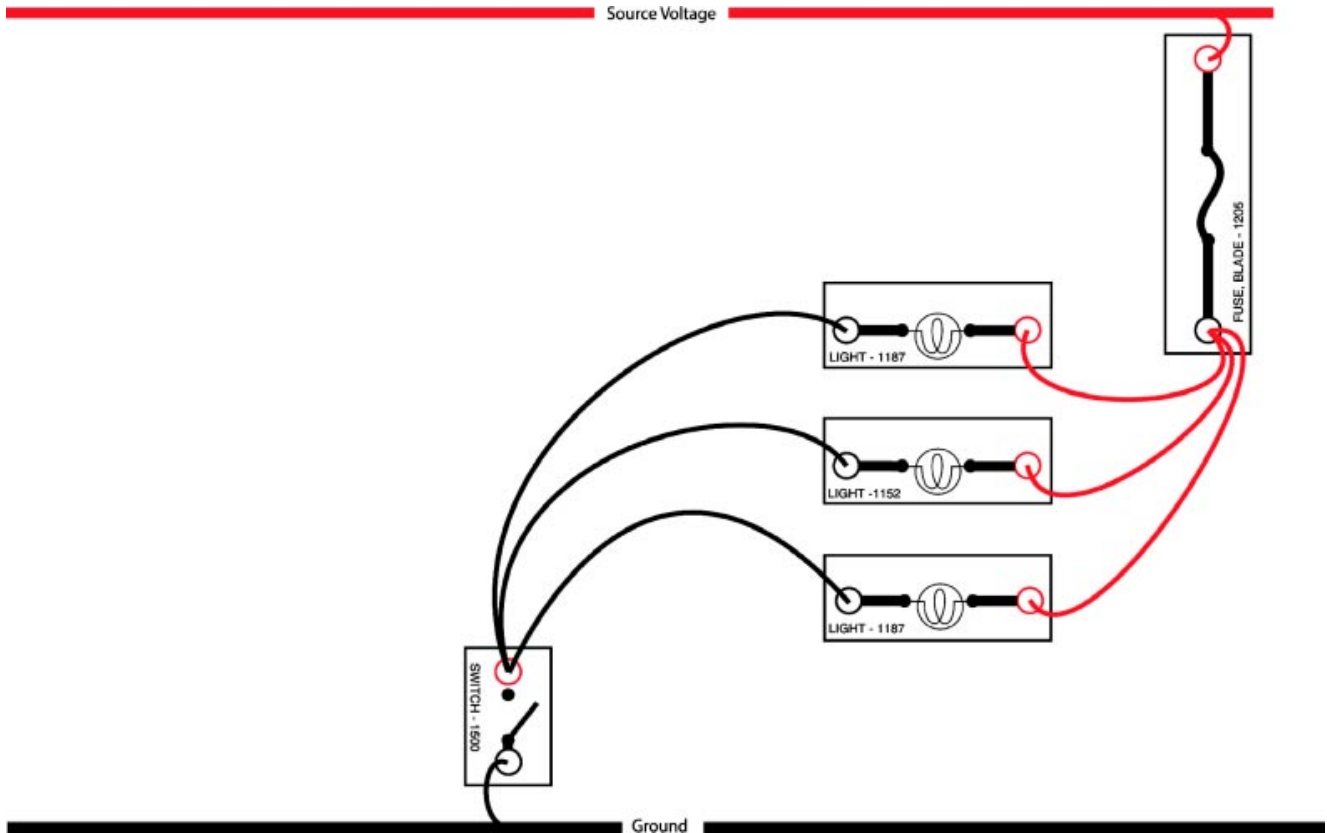

Fig. 2W2-2
TL623f002c-2W2

Did the brightness of the first lamp change? YES / NO (circle one)

If NO, explain why?

10. Measure the resistance of the circuit and of each branch (remember to isolate the circuit from the power supply):

Circuit: _____

Branch 1: _____

Branch 2: _____

Branch 3: _____

Is the circuit resistance lower than what you measured in step 8? YES / NO (circle one)

Why? _____



Stop here after completing all the related activities and answering the questions. Inform your instructor that you are ready to review this section.

11. Turn the power supply off. Add resistor 1603 (100 Ω) in the circuit as shown. Turn the power supply on.

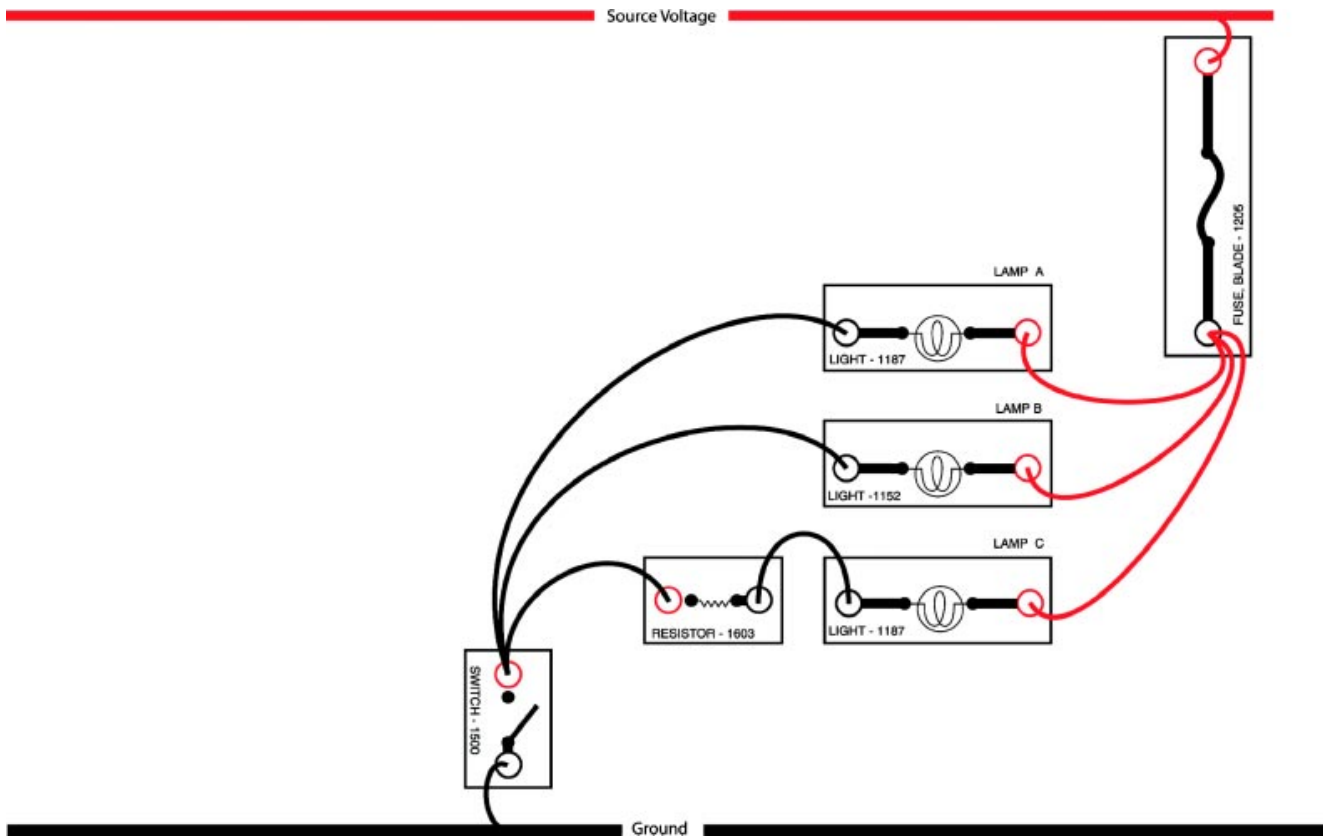

Fig. 2W2-3
 TL623f003c-2W2

What do you notice about the lamps? _____

Why? _____

Parallel Circuits

12. Measure the voltage drop across each of the loads:

Lamp A: _____

Lamp B: _____

Lamp C: _____

Resistor: _____

13. Measure the amperage of the circuit at the following test points:

At fuse: _____

At branch 1: _____

At branch 2: _____

At branch 3: _____

14. Unscrew one lamp. Did they all turn off? YES / NO (circle one)

Why? _____

15. Explain the relationship between Voltage, Amperage, and Resistance based on your readings made in this worksheet.

Voltage: _____

Amperage: _____

Resistance: _____

16. Turn off the power supply and the DMM.



Stop here after completing all the related activities and answering the questions. Inform your instructor that you are ready to review this section.

Parallel Circuits

Name: _____ Date: _____

Review this sheet as you are doing the Parallel Circuits worksheet. Check each category after viewing the instructor's presentation and completing the worksheet. Ask the instructor if you have questions regarding the topics provided below. Additional space is provided under topic for you to list any other concerns that you would like you instructor to address. The comments section is provided for your personal comments, information, questions, etc.

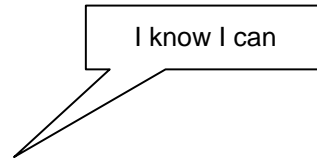
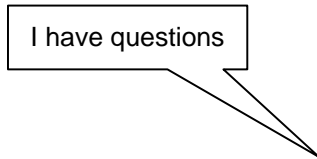

Topic	Comment		
Predict Available Voltage			
Measure Available Voltage			
Measure Voltage Drop			
Measure Circuit Amperage			
Measure Resistance			



WORKSHEET 2-3

Series-Parallel Circuits

Worksheet Objectives

When you have completed this worksheet, you will be able to apply the following electrical troubleshooting techniques to series-parallel circuits:

- Predict and measure:
 - available voltage at various points in the circuit.
 - voltage drops at various points in the circuit.
- Measure amperage and resistance in the circuit.

Tools and Equipment

For this exercise you will need the following:

- Technician's Handbook
- Toyota Electrical Training Kit
- Digital multimeter (DMM)
- EWD

Complete the related activities outlined in each step which include:

- Assembling the circuit as shown for each worksheet section.
- Use the DMM to take voltage, amperage, and resistance measurements.
- Answer the related questions.



Stop your work when you see the  sign. You will review your work with the instructor before continuing to the next section.

Exercise 1: Predict Available Voltage

A series-parallel circuit is a combination of series and parallel branches in one circuit. Diagnose the series portion as a series circuit and the parallel portion as a parallel circuit.

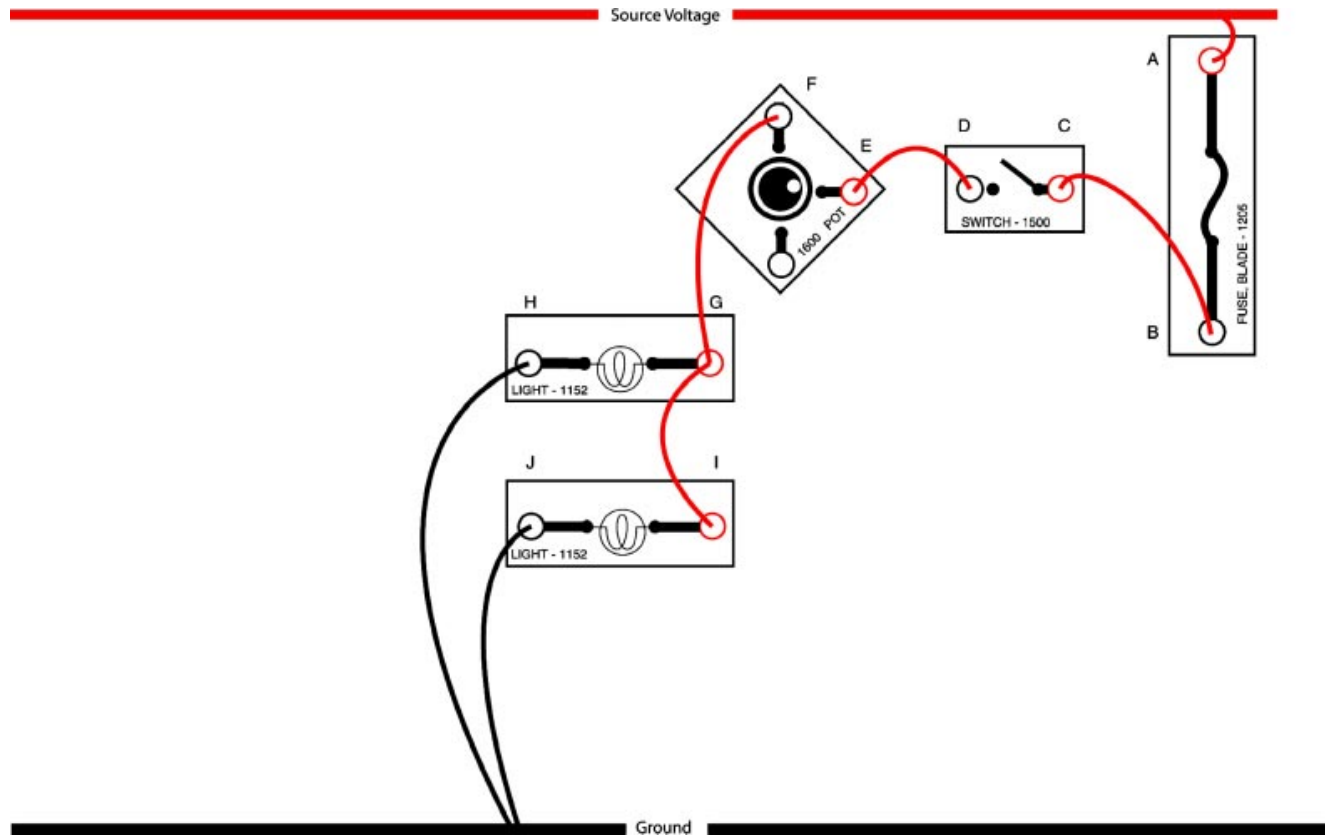

Fig. 2W3-1
TL623f001c-2W3

1. Build the circuit shown on the above electrical training kit.
 - Make sure switch is closed.

Series-Parallel Circuits

2. Measure the available voltage with the switch closed and circuit ON.

NOTE: Measure available voltage when the bulbs are dim and at full brightness by adjusting the potentiometer.

	Bulbs Are Dim	Bulbs Are Bright
A.	_____	_____
B.	_____	_____
C.	_____	_____
D.	_____	_____
E.	_____	_____
F.	_____	_____
G.	_____	_____
H.	_____	_____
I.	_____	_____
J.	_____	_____



Stop here after completing all the related activities and answering the questions. Inform your instructor that you are ready to review this section.

3. Predict the voltage drop at each location shown on the wiring diagram. Write the values on the diagram in the designated blank spaces and state if the test is performed with bulbs bright or dim. Measure the actual voltage drop and note the readings in the actual column.

	PREDICTED	ACTUAL
Switch	_____	_____
Potentiometer	_____	_____
Lamp 1	_____	_____
Lamp 2	_____	_____



Stop here after completing all the related activities and answering the questions. Inform your instructor that you are ready to review this section.

4. Measure the current in the series and parallel portions of the circuit. Take three readings as follows:

- Bulbs are not lit
- Bulbs are dim
- Bulbs are bright

Take readings at the following test points:

- Series portion of circuit: Test point "E"
- Parallel portion of circuit: Test point "J"

	Bulbs Are Dim	Bulbs Are Bright
Series Current	_____	_____
Parallel Current	_____	_____



Stop here after completing all the related activities and answering the questions. Inform your instructor that you are ready to review this section.

5. Turn the power supply off and isolate it from the circuit. Measure the resistance in the series portion of the circuit: (Note, the resistance varies so measure the minimum and maximum.)

6. Measure the resistance in the parallel section:



Stop here after completing all the related activities and answering the questions. Inform your instructor that you are ready to review this section.

Series-Parallel Circuits

Name: _____ Date: _____

Review this sheet as you are doing the Series-Parallel Circuits worksheet. Check each category after viewing the instructor’s presentation and completing the worksheet. Ask the instructor if you have questions regarding the topics provided below. Additional space is provided under topic for you to list any other concerns that you would like your instructor to address. The comments section is provided for your personal comments, information, questions, etc.

I have questions

I know I can

Topic			Comment
Measure Available Voltage			
Predict Voltage Drop			
Measure Current			
Measure Resistance			



Notes



WORKSHEET 2-4
Solving Problems in a Series-Parallel Circuit

Worksheet Objectives

In this worksheet you will assemble a series-parallel circuit. When you have completed this worksheet, you will have explained what can occur when circuit problems are present.

Tools and Equipment

For this exercise you need the following:

- Electrical simulator
- Digital multimeter (DMM)

Exercise

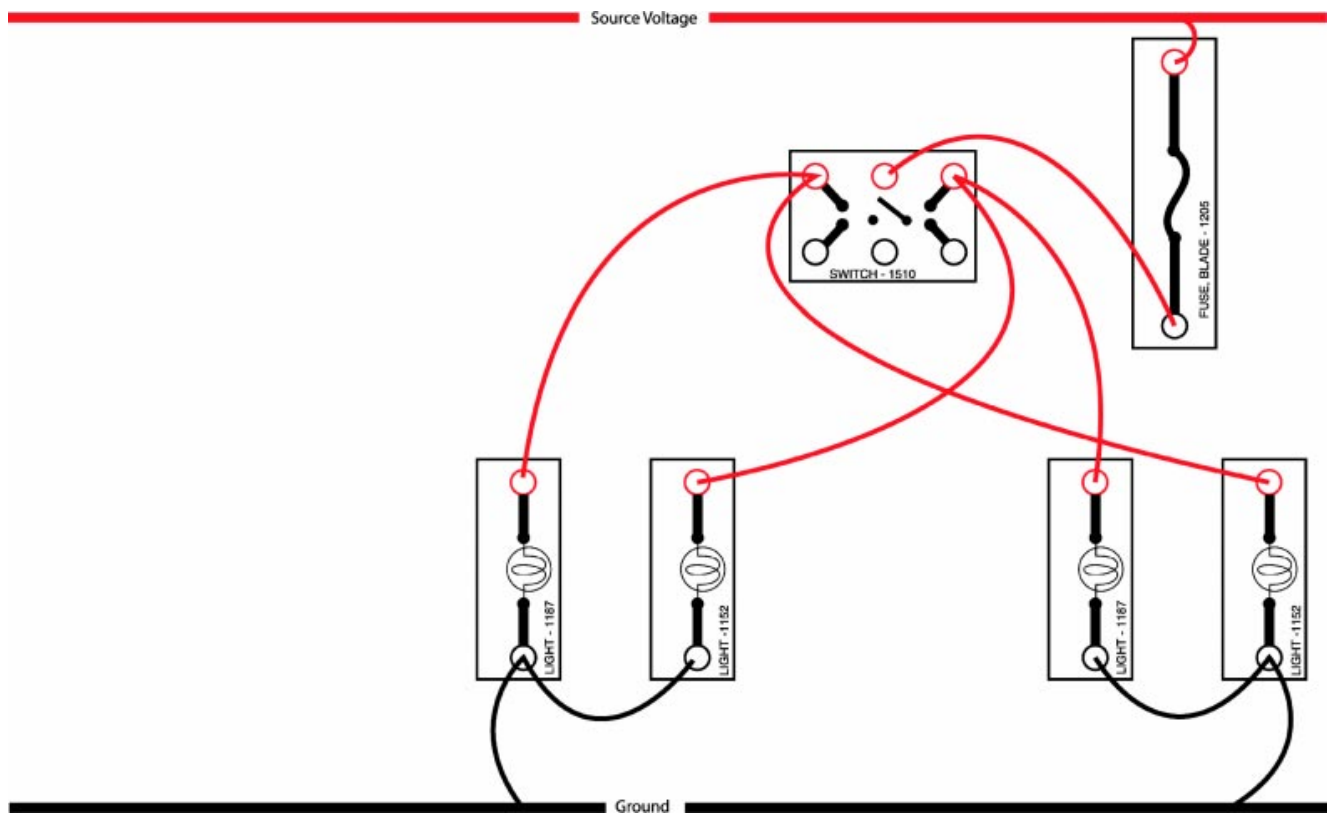

Fig. 2W4-1
 TL623f001c-2W4

1. Assemble the series-parallel circuit shown above.
2. Turn on the power supply and verify the circuit operates correctly.

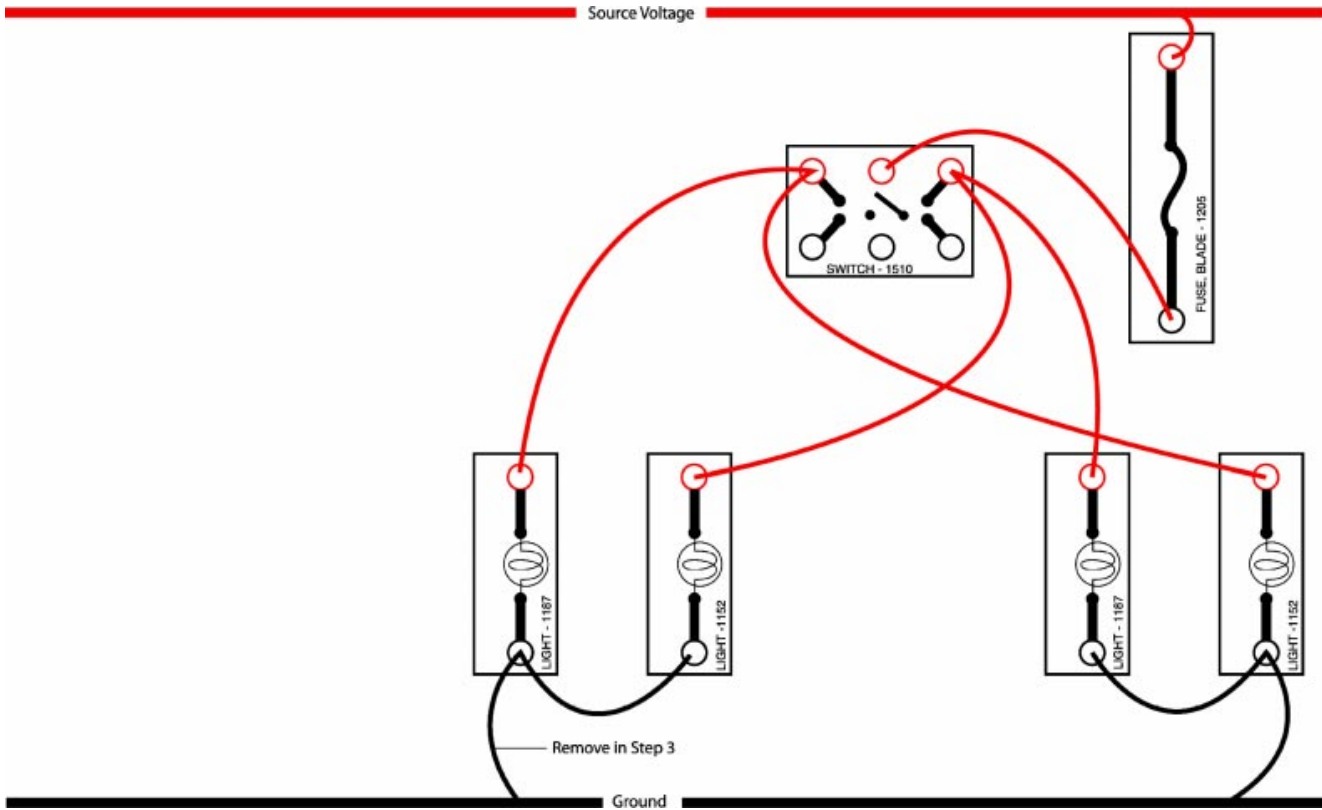

Fig. 2W4-2
TL623f002c-2W4

3. Create an open in the circuit as shown above.
4. How does the circuit function with the open?

5. Explain what happened in the circuit with respect to voltage, current, and resistance?

Voltage: _____

Current: _____

Resistance: _____



Stop here after completing all the related activities and answering the questions. Inform your instructor that you are ready to review this section.

Solving Problems in a Series-Parallel Circuit

Name: _____ Date: _____

Review this sheet as you are doing the Solving Problems in a Series-Parallel Circuit worksheet. Check each category after viewing the instructor's presentation and completing the worksheet. Ask the instructor if you have questions regarding the topics provided below. Additional space is provided under topic for you to list any other concerns that you would like you instructor to address. The comments section is provided for your personal comments, information, questions, etc.

I have questions

I know I can

Topic	Comment		
Circuit Function			
Voltage Function			
Current Function			
Resistance Function			



Notes



WORKSHEET 2-5 *Electrical Symbols*

Worksheet Objectives

When you have completed this worksheet, you will be able to:

- Identify electrical symbols used in Toyota wiring diagrams.
- Know where in the EWD manual to find unfamiliar electrical symbols.

Tools and Equipment

For this exercise you will need the following:

- Technician's Handbook
- Pen or pencil
- EWD

Exercise 1: Identifying Electrical Symbols

Use the diagram in Figure 2W5-1 to complete these activities:

- Write the names of the symbols in the blank spaces provided on the diagram.
- Identify whether switch and relay contacts are open or closed. Write your answer on the diagram.
- Fill in the correct term for the question about transistor current.
- Determine whether the crossing wires are connected or not connected. Write your answer on the diagram.

NOTE Use the TIS or the How to Use This Manual section of an electrical wiring diagram book to look up any symbols you do not know.





 <p>_____ (Symbol Name) Contact is normally _____ (open / closed)</p>	 <p>_____ (Symbol Name) Contact is normally _____ (open / closed)</p>
 <p>_____ (Symbol Name)</p>	 <p>_____ (Symbol Name) Contact is normally _____ (open / closed)</p>
 <p>_____ (Symbol Name)</p>	 <p>_____ (Symbol Name) Stops or passes current, depending on the voltage applied to the _____</p>
 <p>_____ These wires are: <input type="checkbox"/> Connected <input type="checkbox"/> Not connected</p>	

Fig. 2W5-1
TL623f001-2W5

Electrical Symbols

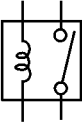
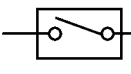
Name: _____ Date: _____

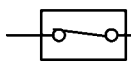
Review this sheet as you are doing the Electrical Symbols worksheet. Check each category after viewing the instructor's presentation and completing the worksheet. Ask the instructor if you have questions regarding the topics provided below. Additional space is provided under topic for you to list any other concerns that you would like you instructor to address. The comments section is provided for your personal comments, information, questions, etc.

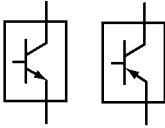
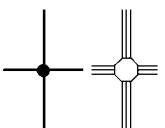
I have questions

I know I can

Topic	Comment		
Identify Electrical Symbols			



Notes



WORKSHEET 2-6
Tracing Current

Worksheet Objectives

When you have completed this worksheet, you will be able to:

- Trace current in any Toyota wiring diagram.
- Predict available voltage at specified points in a circuit.

Tools and Equipment

For this exercise you will need the following:

- Technician's Handbook
- Red pen or pink highlighter
- Green pen or highlighter
- EWD

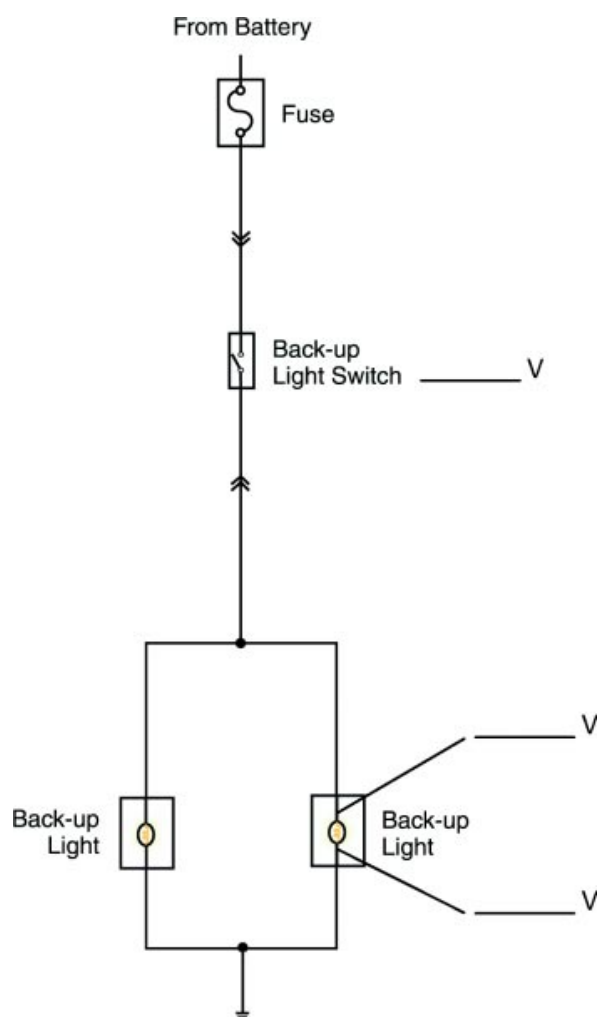

Fig. 2W6-1
TL623f001c-2W6

Exercise 1: Tracing Current Flow

In the back-up lights circuit above:

- Use a red pen or pink highlighter to trace current in the positive (source) side of the circuit.
- Use a green pen or highlighter to trace current in the negative (ground) side of the circuit.
- Analyze the circuit to predict available voltage at the back-up lights switch and at the right back-up lamp. Write those values on the wiring diagram.

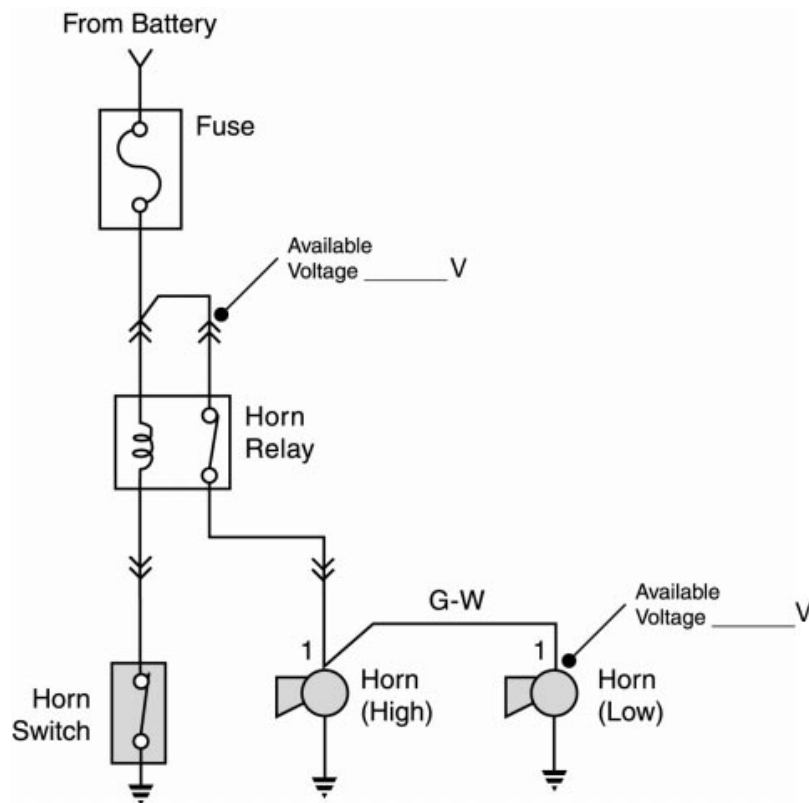

Fig. 2W6-2
TL623f002-2W6

Exercise 2: Tracing Current

In the Horn circuit above:

- Use a red pen or pink highlighter to trace current in the positive (source) side of the circuit.
- Use a green pen or highlighter to trace current in the negative (ground) side of the circuit.

Analyze the circuit to predict available voltage at the horn relay connector and at the low horn lamp. Write those values on the wiring diagram.

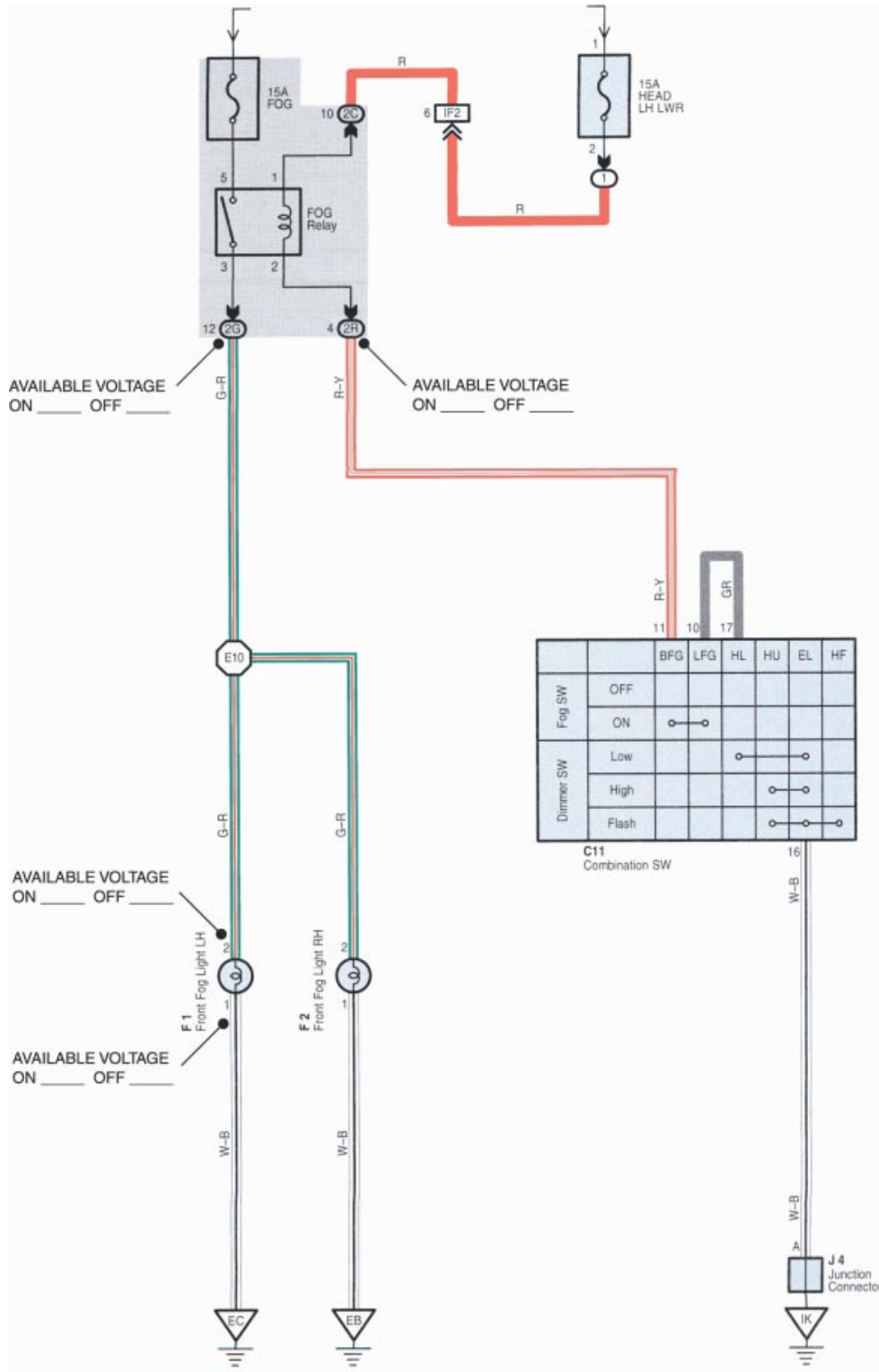

Fig. 2W6-3
TL623f003c-2W6

Exercise 3: Tracing Current

In the fog lights circuit on the previous page:

- Use a red pen or pink highlighter to trace current in the positive (source) side of the circuit.
- Use a green pen or highlighter to trace current in the negative (ground) side of the circuit.

Analyze the circuit to predict available voltage at the fog light relay and at the right hand fog lamp. Write those values on the wiring diagram.

Tracing Current

Name: _____ Date: _____

Review this sheet as you are doing the Tracing Current worksheet. Check each category after viewing the instructor's presentation and completing the worksheet. Ask the instructor if you have questions regarding the topics provided below. Additional space is provided under topic for you to list any other concerns that you would like you instructor to address. The comments section is provided for your personal comments, information, questions, etc.

I have questions

I know I can

Topic

Comment

Trace Current Flow			
Predict Available Voltage			



WORKSHEET 2-7
Electrical Wiring Diagrams

Worksheet Objectives

When you have completed this worksheet, you will be able to:

- Find specific wiring diagrams in the Toyota EWD.
- Determine whether a circuit is source controlled or ground controlled.

Tools and Equipment

For this exercise you will need the following:

- Technician’s Handbook
- Pen or pencil
- EWD

Exercise 1: Finding Circuit Wiring Diagrams

Find the following electrical wiring diagrams. Write the page number of the diagram in the first column. Place a check mark beside each one to specify whether it is source or ground controlled.

	Page	Source	Ground
1. Fog Lights			
2. Stop Light			
3. Shift Lock			

Electrical Wiring Diagrams

Name: _____ Date: _____

Review this sheet as you are doing the Electrical Wiring Diagrams worksheet. Check each category after viewing the instructor's presentation and completing the worksheet. Ask the instructor if you have questions regarding the topics provided below. Additional space is provided under topic for you to list any other concerns that you would like your instructor to address. The comments section is provided for your personal comments, information, questions, etc.

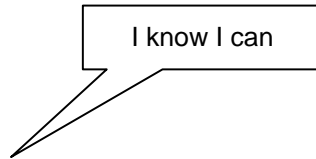
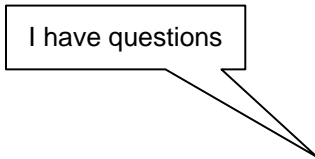

Topic	Comment		
Finding Circuit Wiring Diagrams			
Determine if Circuit is Source or Ground Controlled			



WORKSHEET 2-8
Back-up Lights Circuit

Vehicle	Year/Prod. Date	Engine	Transmission
---------	-----------------	--------	--------------

Worksheet Objectives

When you have completed this worksheet, you will be able to:

- Trace current in any Toyota wiring diagram.
- Predict available voltage at specified points in a circuit.

Tools and Equipment

For this exercise you will need the following:

- Technician's Handbook
- EWD
- Vehicle

Exercise 1: On-Vehicle (optional)

Use the appropriate vehicle wiring diagram to complete this exercise on the back-up lights circuit.

1. Where is the fuse for the circuit located?

2. What is the current rating of the fuse? _____ amps

3. Where is the circuit grounded?

4. How would the circuit be effected by a high resistance connection to ground?

5. ON-VEHICLE - Apply the parking brake. Turn the ignition switch to ON, but do not start the engine. Measure the voltage drop across the back-up light switch.

Record the value here: _____ volts.

6. ON-VEHICLE - Measure the voltage drop across each back-up light. Record the values here:

LEFT _____ volts; RIGHT _____ volts.

7. Turn the ignition switch to LOCK and return the vehicle to its normal condition.

Back-up Lights Circuit

Name: _____ Date: _____

Review this sheet as you are doing the Back-up Lights Circuit worksheet. Check each category after viewing the instructor's presentation and completing the worksheet. Ask the instructor if you have questions regarding the topics provided below. Additional space is provided under topic for you to list any other concerns that you would like you instructor to address. The comments section is provided for your personal comments, information, questions, etc.

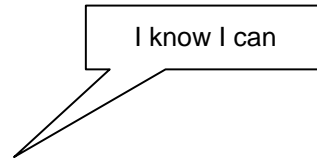
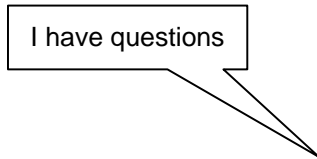

Topic	Comment		
Predict Available Voltage			
Trace Current			
Measure Voltage Drop			



WORKSHEET 2-9 *Relays*

Worksheet Objectives

When you have completed this worksheet, you will be able to:

- Determine whether relay contacts are normally open or normally closed.
- Test relays using continuity, voltage, and operational checks.
- Predict and measure available voltage at various points in a relay controlled circuit.

Tools and Equipment

For this exercise you will need the following:

- Technician's Handbook
- Electrical simulator
- Digital multimeter (DMM)

Complete the related activities outlined in each step which include:

- Assembling the circuit as shown for each worksheet section.
- Use the DMM to take voltage, amperage, and resistance measurements.
- Answer the related questions.



Stop your work when you see the  sign. You will review your work with the instructor before continuing to the next section.

Exercise 1: Relay Terminal Identification

1. Obtain relay part number 1801 from the Electrical Simulator.
2. Refer to the connector illustration below to identify the relay coil and contact terminals of the relay.
3. Use a DMM to check continuity between the two sets of relay terminals (relay coil and relay contact).
4. Use the results to fill in the table below:

Relay Coil		Relay Contacts	
Terminal #'s		Terminal #'s	
Continuity		Continuity	
YES	NO	YES	NO

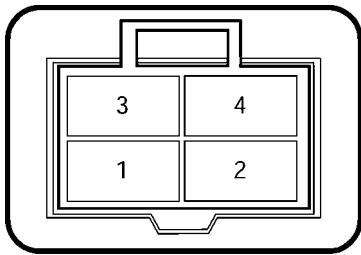

Fig. 2W9-1
TL623f001-2W9

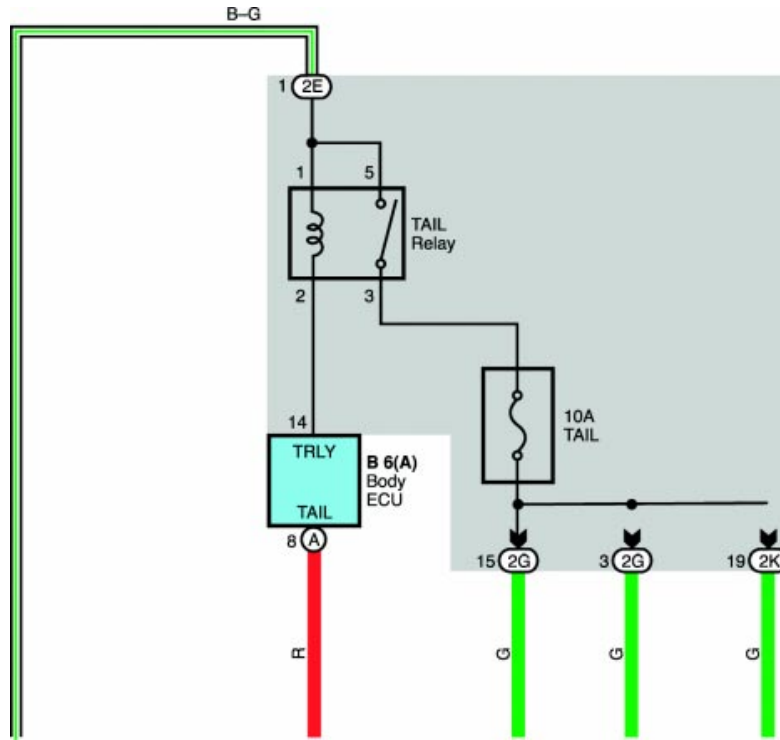

Fig. 2W9-2
TL623f002c-2W9

Exercise 2: Relay-Controlled Circuit

1. Refer to the wiring diagram above. Are the relay contacts normally open (NO) or normally closed (NC)? Indicate your answer with a check mark below:

NO _____ NC _____

- Build the relay-controlled circuit on the electrical training kit (functionally identical to the circuit shown in Figure 2W9-3).

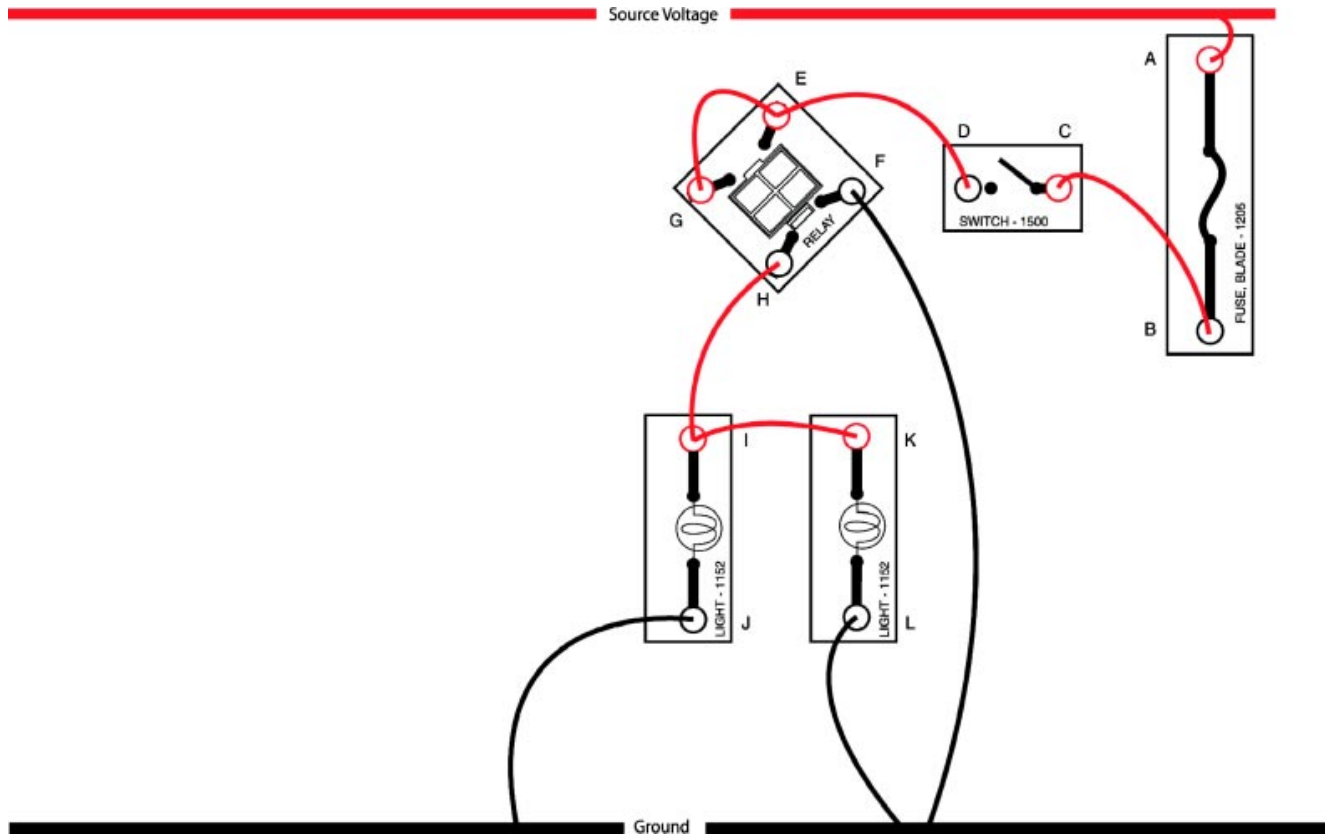

Fig. 2W9-3
TL623f003c-2W9

- What will happen when you close the switch?

- Switch the power supply on.
- Listen closely to the relay as you close the switch. Does the relay click?

YES / NO (circle one)

- Does hearing the click confirm that the relay is operating correctly?

- Why do the lamps go on when you close the switch?

Relays

8. Measure the current flowing through the relay coil (insert the DMM into the circuit at point "F"). Record the measurement in the blank space below (remember to specify the correct units, amps or milliamps):

9. Measure the current flowing through the lamps (insert the DMM into the circuit at point "H"). Record the measurement in the blank space below:

10. Which path (through the relay coil or through the lamps) conducts more current?



Stop here after completing all the related activities and answering the questions. Inform your instructor that you are ready to review this section.

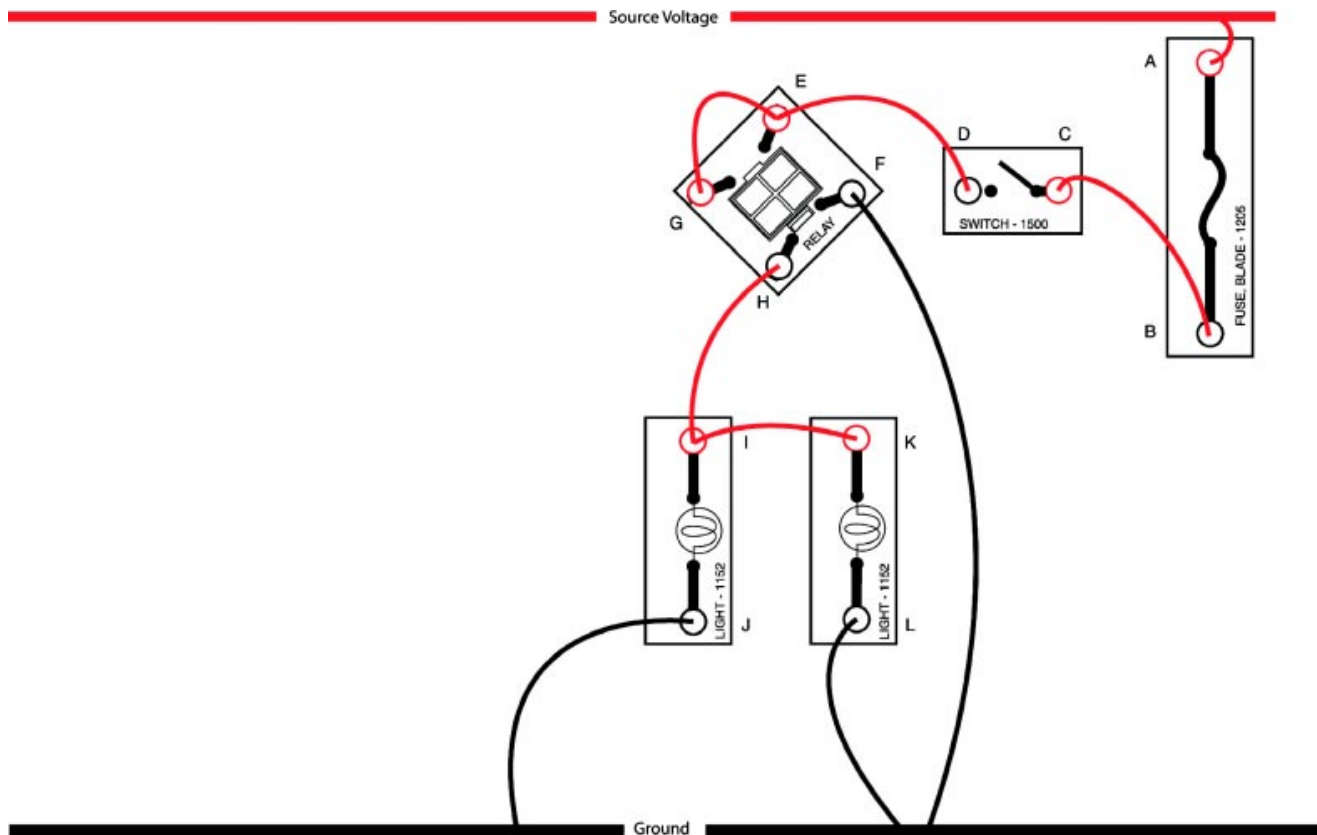

Fig. 2W9-4
TL623f003c-2W9

Exercise 3: Voltage Tests

1. Predict the available voltage at each numbered test point in the circuit. Make your predictions for the circuit as it is shown (power applied from the battery, switch closed, relay energized). Record your predictions below.

	PREDICTED	ACTUAL
A.	_____	_____
B.	_____	_____
C.	_____	_____
D.	_____	_____
E.	_____	_____
F.	_____	_____
G.	_____	_____

	PREDICTED	ACTUAL
H.	_____	_____
I.	_____	_____
J.	_____	_____
K.	_____	_____
L.	_____	_____

2. Connect the black lead of the DMM to the electrical training kit ground. Touch the red lead to each test point and record the actual results above.



Stop here after completing all the related activities and answering the questions. Inform your instructor that you are ready to review this section.

Disassemble the circuit and return all components into the electrical simulator storage case. Turn off the DMM (you will use the DMM in other worksheets so you do not need to store it at this time).

Relays

Name: _____ Date: _____

Review this sheet as you are doing the Relays worksheet. Check each category after viewing the instructor's presentation and completing the worksheet. Ask the instructor if you have questions regarding the topics provided below. Additional space is provided under topic for you to list any other concerns that you would like you instructor to address. The comments section is provided for your personal comments, information, questions, etc.

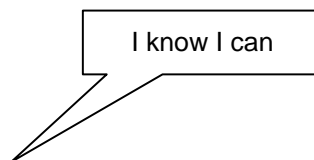
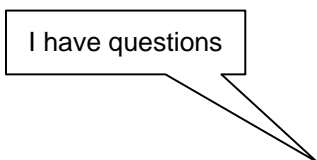

Topic	Comment		
Check Continuity			
Determine if Relay is Normally Open (NO) or Normally Closed (NC)			
Measure Current Flow			
Predict Available Voltage			
Measure Available Voltage			



WORKSHEET 2-10
Heater Control Relay

Worksheet Objectives

In this worksheet you will do the following:

- Measure the resistance through various parts of the heater control relay.
- Apply your resistance readings to diagram how the relay is wired.

Tools and Equipment

For this exercise you need the following:

- Technician's Handbook
- Electrical simulator
- Digital multimeter (DMM)

Section 1: Relay Resistance Testing

1. Obtain the heater control relay (#1803) from your electrical simulator kit. Use the DMM to make the following resistance measurements based on the labeled diagram below:

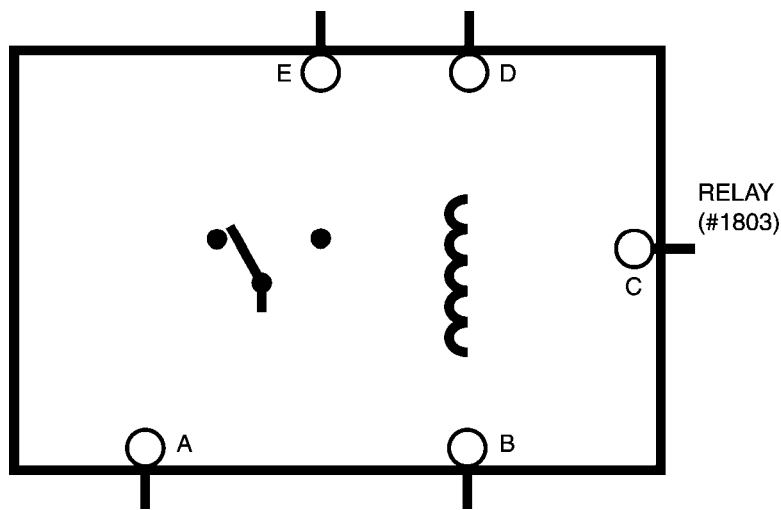

Fig. 2W10-2
TL623f001-2W10

Note - OL displayed on the meter indicates an open circuit. Values close to 0 Ω indicate a closed circuit (continuity). Any other values indicate circuit resistance.

A - B _____ Ω A - C _____ Ω A - D _____ Ω A - E _____ Ω B - C _____ Ω B - D _____ Ω B - E _____ Ω C - D _____ Ω C - E _____ Ω D - E _____ Ω

2. Use your measurements to determine how the relay is wired. Indicate the wiring connections by drawing them on the diagram of the relay above.



Stop here after completing all the related activities and answering the questions. Inform your instructor that you are ready to review this section.

Heater Control Relay

Name: _____ Date: _____

Review this sheet as you are doing the Heater Control Relay worksheet. Check each category after viewing the instructor's presentation and completing the worksheet. Ask the instructor if you have questions regarding the topics provided below. Additional space is provided under topic for you to list any other concerns that you would like you instructor to address. The comments section is provided for your personal comments, information, questions, etc.

I have questions

I know I can

Topic	Comment		
Measure Resistance			
Determine How Relay is Wired			



Notes



WORKSHEET 2-11
Heater Switch, Resistor Pack, and Control Relay

Worksheet Objectives

In this worksheet you will assemble a blower motor control circuit that uses resistors to vary motor output. A light bulb is used instead of a motor in this example.

Tools and Equipment

For this exercise you need the following:

- Technician’s Handbook
- Electrical simulator
- Digital multimeter (DMM)

Section 1: Relay Resistance Testing

1. Place the relay on the circuit board and connect the two terminals from the relay coil to the power source. Use a fuse and SPST switch as shown below.

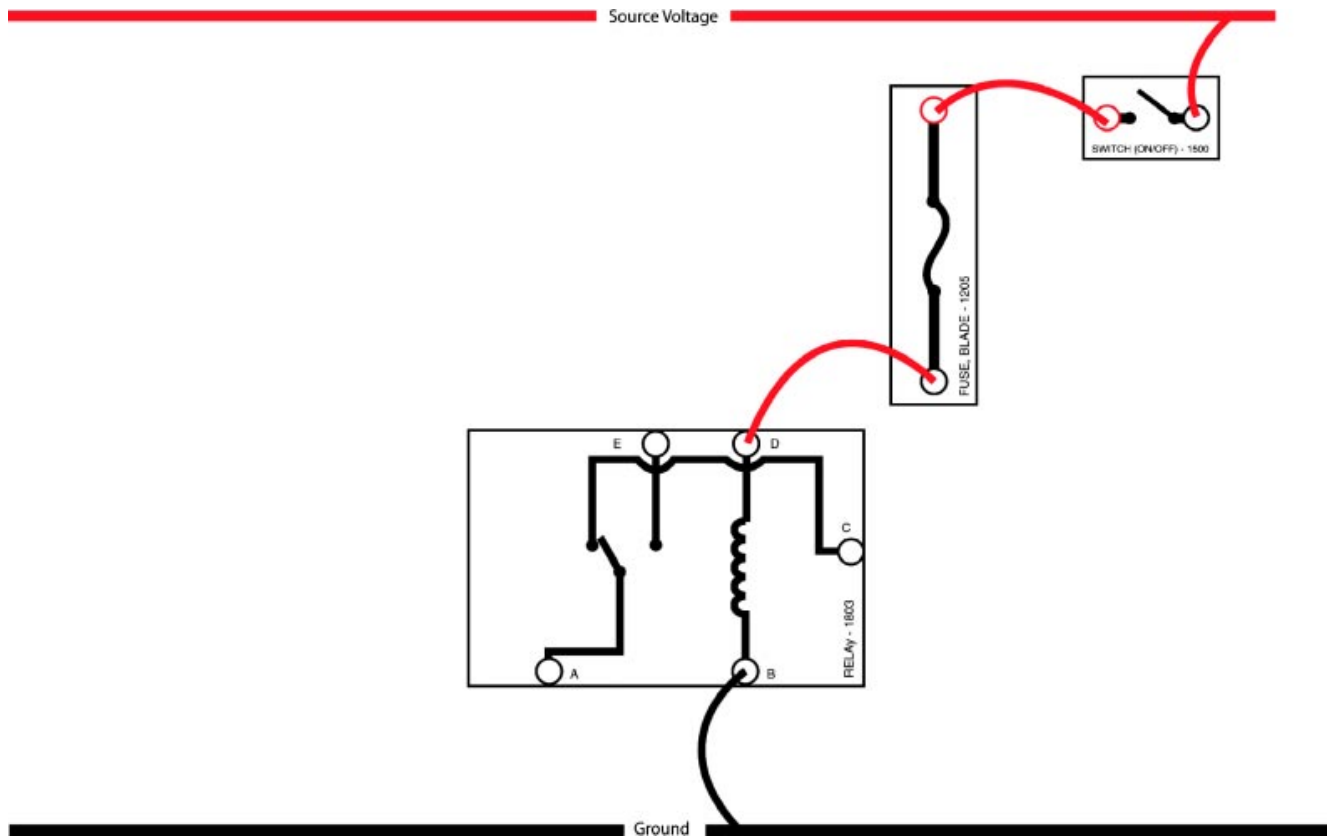

Fig. 2W11-2
 TL623f001c-2W11

2. Turn the relay on and off to verify it is working (you should hear a click when the relay contacts open and close when power is turned on and off).
3. Turn the power supply off.
4. Use the heater control switch (#1650) and a lamp (#1152) to assemble the circuit shown below.

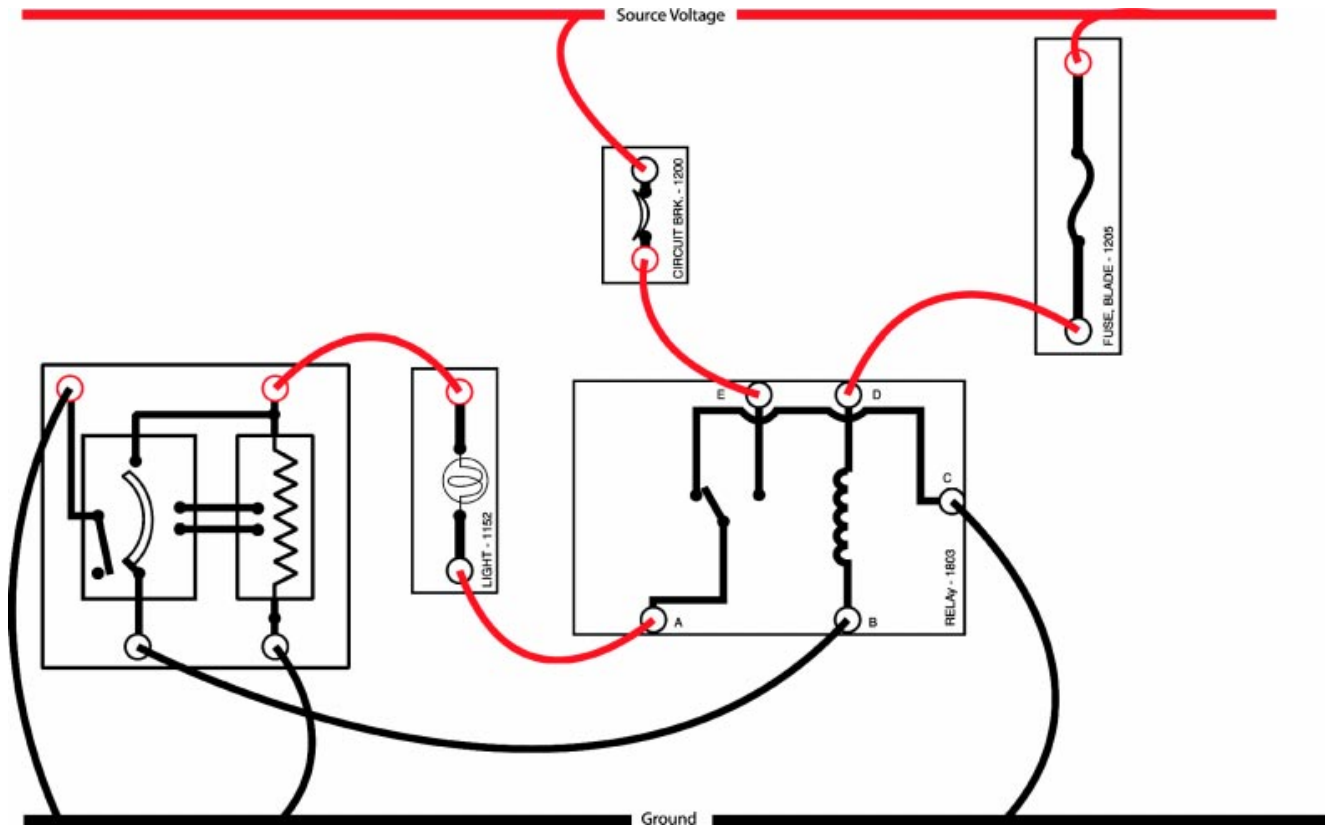

Fig. 2W11-2
TL623f001c-2W11

5. Turn on the power supply and verify the circuit operates correctly. Does the bulb change brightness as the switch is moved through each position?

YES / NO (circle one)

If yes, why?

6. Measure the voltage drop across the bulb in each switch position:

Position 1: _____ Position 3: _____

Position 2: _____ Position 4: _____

Heater Switch, Resistor Pack, and Control Relay

Why does the voltage drop change across the lamp as the switch is moved?

7. Measure the current for the following:

Relay coil _____

Bulb (at brightest switch position) _____



Stop here after completing all the related activities and answering the questions. Inform your instructor that you are ready to review this section.

Heater Switch, Resistor Pack, and Control Relay

Name: _____ Date: _____

Review this sheet as you are doing the Heater Switch, Resistor Pack, and Control Relay worksheet. Check each category after viewing the instructor's presentation and completing the worksheet. Ask the instructor if you have questions regarding the topics provided below. Additional space is provided under topic for you to list any other concerns that you would like your instructor to address. The comments section is provided for your personal comments, information, questions, etc.

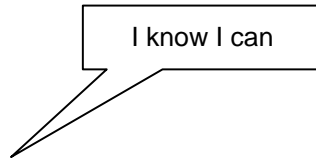
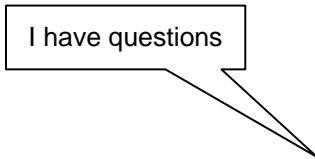

Topic	Comment		
Measure Voltage Drop			
Measure Current			



WORKSHEET 2-12
Using a Flasher Circuit

Worksheet Objectives

In this worksheet you will do the following:

- Assemble an automotive flasher (turn signal) type circuit.
- Demonstrate your knowledge of circuit operation by answering the related questions.

Tools and Equipment

For this exercise you need the following:

- Technician's Handbook
- Electrical simulator
- Digital multimeter (DMM)

Section 1: Circuit Assembly

1. Assemble the circuit shown below:

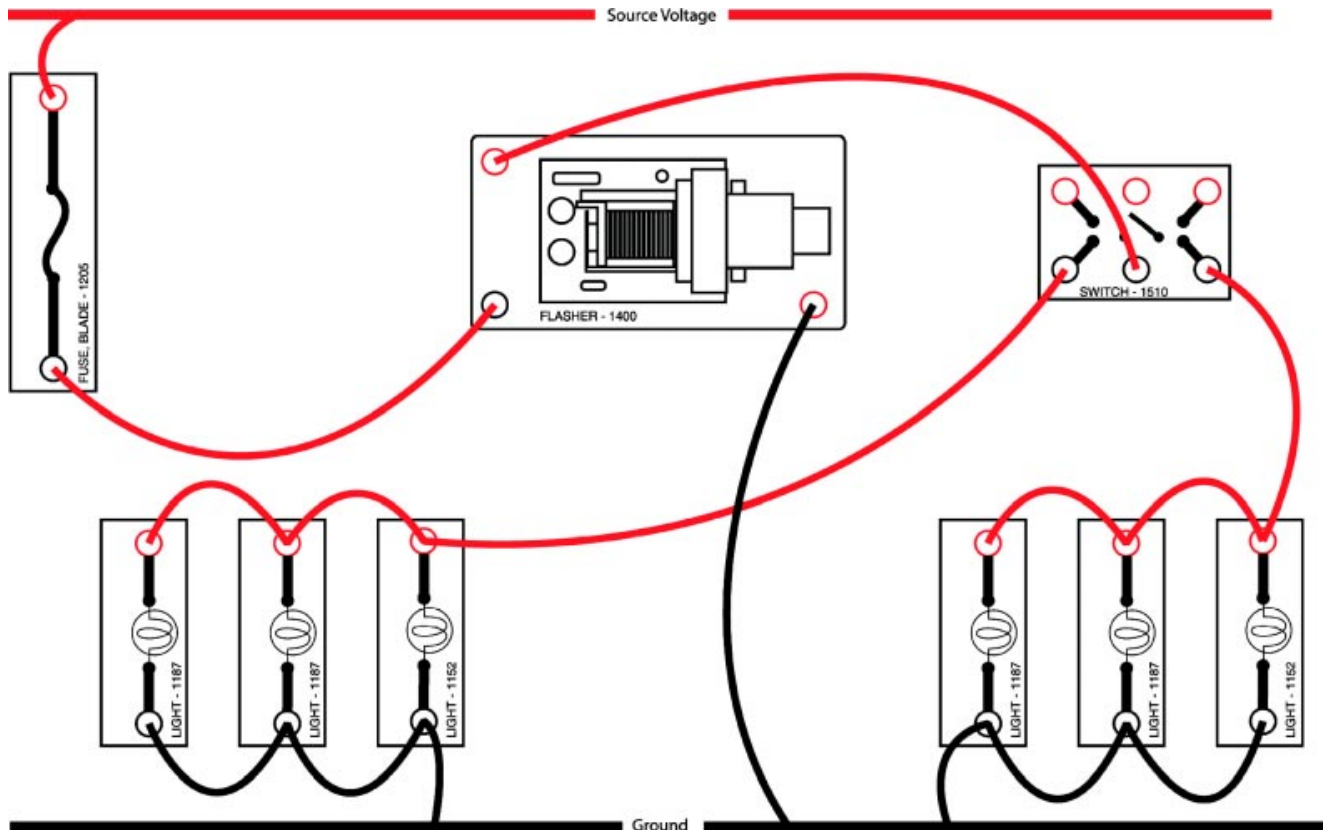

Fig. 2W12-1
TL623f001c-2W12

2. Turn on the power supply. Operate the switch. Do either set of lights flash? YES / NO (circle one).

If No, then there is not enough current draw in the circuit to operate the flasher. Add the components shown below and retry.

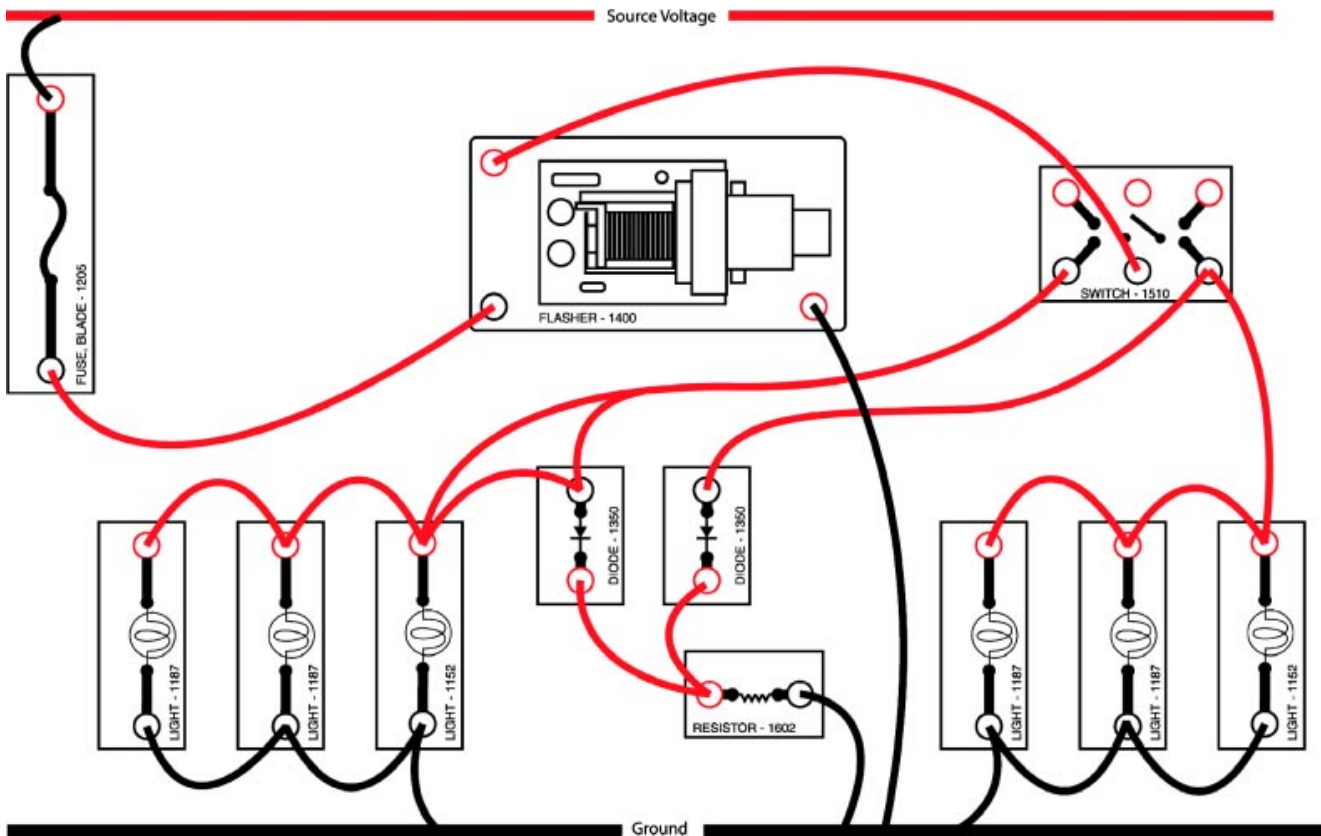

Fig. 2W12-2
TL623f002c-2W12

3. Why are the diodes required?



Stop here after completing all the related activities and answering the questions. Inform your instructor that you are ready to review this section.

Using a Flasher Circuit

Name: _____ Date: _____

Review this sheet as you are doing the Using a Flasher Circuit worksheet. Check each category after viewing the instructor's presentation and completing the worksheet. Ask the instructor if you have questions regarding the topics provided below. Additional space is provided under topic for you to list any other concerns that you would like your instructor to address. The comments section is provided for your personal comments, information, questions, etc.

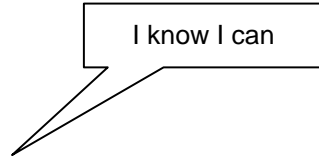
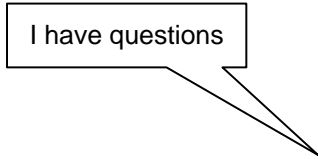

Topic	Comment		
Circuit Function			



Notes



WORKSHEET 2-13
Use a Transistor in a Circuit

Worksheet Objectives

In this worksheet you will do the following:

- Follow the wiring diagram to assemble a circuit with a transistor.
- Measure current through the base, collector, and emitter of the transistor.

Tools and Equipment

For this exercise you need the following:

- Technician’s Handbook
- Electrical simulator
- Digital multimeter (DMM)

Section 1: Circuit Assembly

1. Assemble the circuit shown below using components from your electrical simulator.

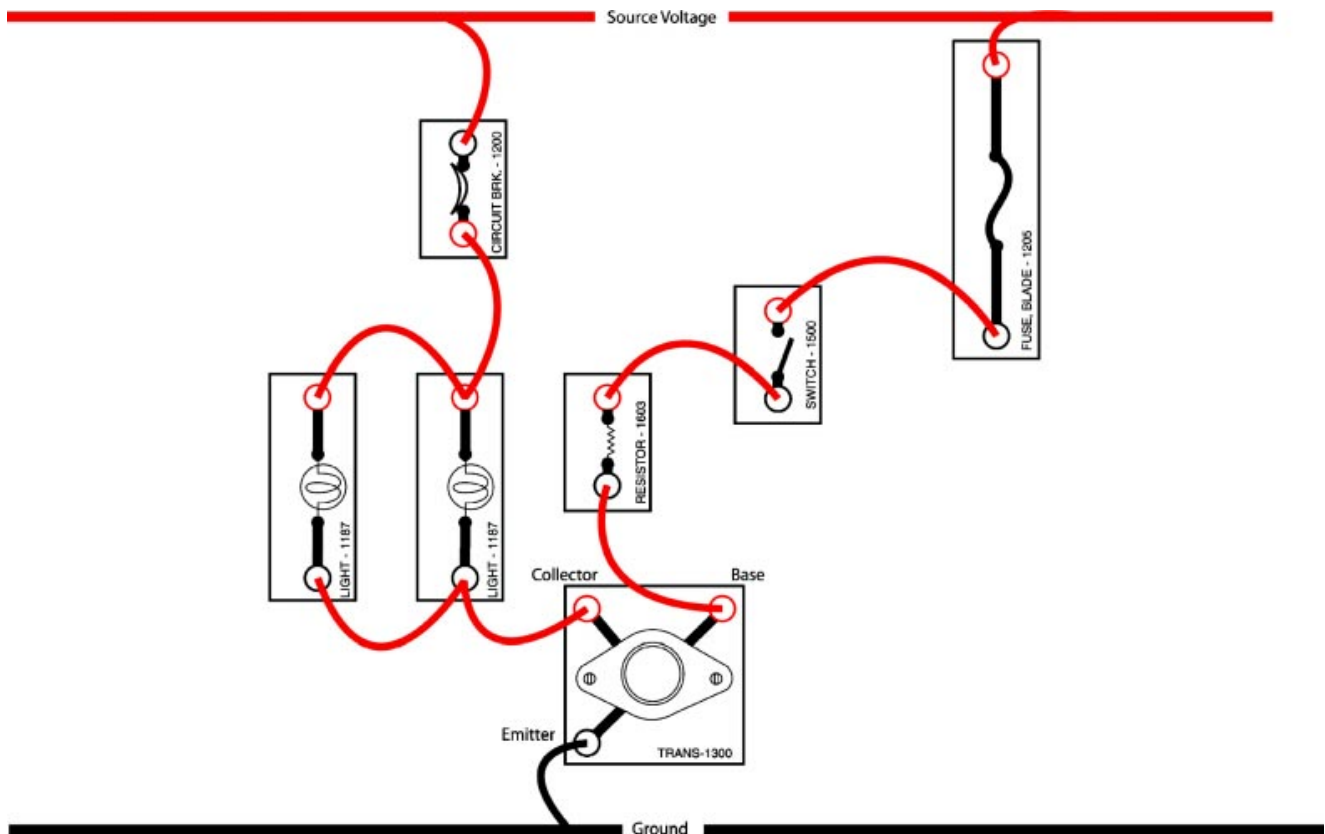

Fig. 2W13-1
TL623f001c-2W13

Section 2: Current Measurement

2. Turn the switch on. Do the bulbs light? YES / NO (circle one).
3. If No, check that the circuit is assembled properly. Use the DMM to verify you have voltage throughout the circuit. If you do, ask your instructor for assistance.
4. Use the DMM and measure current at the following on the transistor:

Base _____

Collector _____

Emitter _____

5. Add the base current value you measured with the collector current value.

Base _____

+

Collector _____

= _____

Does the total equal the current measured at the emitter of the transistor? YES / NO (circle one).

Did you know? The emitter current equals the base current plus the collector current in this type of transistor.

What applications do transistors have in automotive circuits (name at least two)?



Stop here after completing all the related activities and answering the questions. Inform your instructor that you are ready to review this section.

Use a Transistor in a Circuit

Name: _____ Date: _____

Review this sheet as you are doing the Use a Transistor in a Circuit worksheet. Check each category after viewing the instructor’s presentation and completing the worksheet. Ask the instructor if you have questions regarding the topics provided below. Additional space is provided under topic for you to list any other concerns that you would like you instructor to address. The comments section is provided for your personal comments, information, questions, etc.

I have questions

I know I can

Topic	Comment		
Measure Current			
Measure Voltage Drop			



Notes



WORKSHEET 2-14

Harness Repairs

Worksheet Objectives

In this worksheet, you will practice removing and replacing connector pins, soldering wiring splices, and using silicon tape and heat shrink insulation.

Tools and Equipment

For this exercise you will need the following:

- Connector repair kit
- Practice connectors
- Soldering iron
- Solder
- Wire
- Splice bars
- Silicon tape
- Heat shrink tubing
- Heat gun
- Wire stripper



Stop your work when you see the  sign. You will review your work with the instructor before continuing to the next section.

Exercise 1: Connector Repair

1. Obtain a practice connector and the connector repair kit.
2. Remove two or three terminal pins from the connector.
3. Select one terminal pin to replace. Locate a correct replacement terminal pin from the repair kit.
4. Remove and replace the terminal pin.
5. Reinsert the terminals in the connector.



Stop here after completing all the related activities and answering the questions. Inform your instructor that you are ready to review this section.

Exercise 2: Soldering

1. Cut six pieces of wire approximately 6" long.
2. Obtain several splice bars from your instructor.
3. Strip the wire ends using a wire stripper.
4. Join two of the wire pieces using a splice bar. Crimp the splice bar onto the wire ends using the noninsulated area of the wire stripper.
5. Solder the splice.
6. Repeat this for the remaining wire pieces to create three spliced wires.



Stop here after completing all the related activities and answering the questions. Inform your instructor that you are ready to review this section.

Exercise 3: Using Heat Shrink Tubing and Silicon Tape

1. Obtain a piece of heat shrink tubing from your instructor.
2. Use one of the wires from exercise 2 and place a piece of heat shrink tubing over the splice.
3. Use a heat gun to shrink the tubing over the splice.
4. Repeat for the other two wires.
5. Wrap silicon tape around each of the splice locations to completely cover the heat shrink tubing. This provides additional protection and insulation for the wire.
6. (Optional) Solder alligator clips to the end of each wire to make your own jumper leads.



Stop here after completing all the related activities and answering the questions. Inform your instructor that you are ready to review this section.

Harness Repairs

Name: _____ Date: _____

Review this sheet as you are doing the Harness Repairs worksheet. Check each category after viewing the instructor's presentation and completing the worksheet. Ask the instructor if you have questions regarding the topics provided below. Additional space is provided under topic for you to list any other concerns that you would like you instructor to address. The comments section is provided for your personal comments, information, questions, etc.

I have questions

I know I can

Topic			Comment
Repair a Connector			
Soldering			
Using Heat Shrink Tubing and Silicon Tape			



Notes

Section 3

The Battery

The Battery The battery is the main source of electrical energy on Toyota vehicles. The battery powers these major electrical systems:

- Starting
- Ignition
- Charging
- Lighting
- Accessories

The Battery

The battery is the main source of electrical energy in the vehicle.

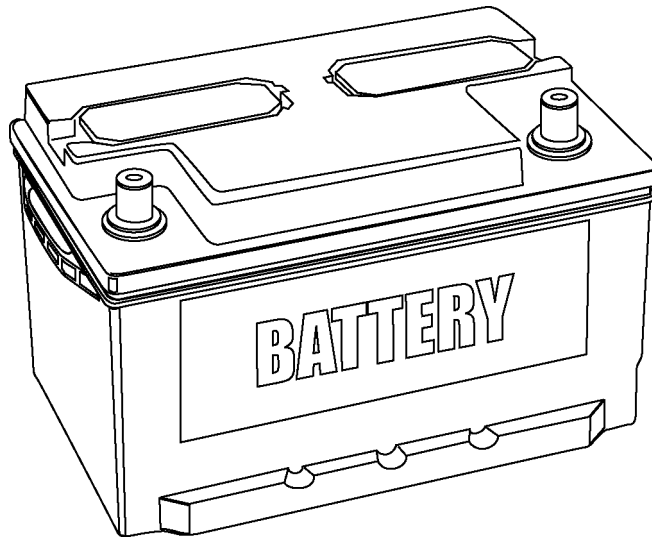

Fig. 3-01
TL623f301

Battery Functions **Engine off** - The battery provides energy to operate lighting and accessories.

Engine starting - The battery provides energy to operate the starter motor and ignition system during starting.

Engine running - The charging system provides most of the energy required with the engine running; the battery acts as a voltage stabilizer to protect voltage sensitive circuits, particularly digital circuits.

Battery Functions

The battery provides energy to operate lights and accessories and to start the engine. It also serves as a voltage stabilizer.

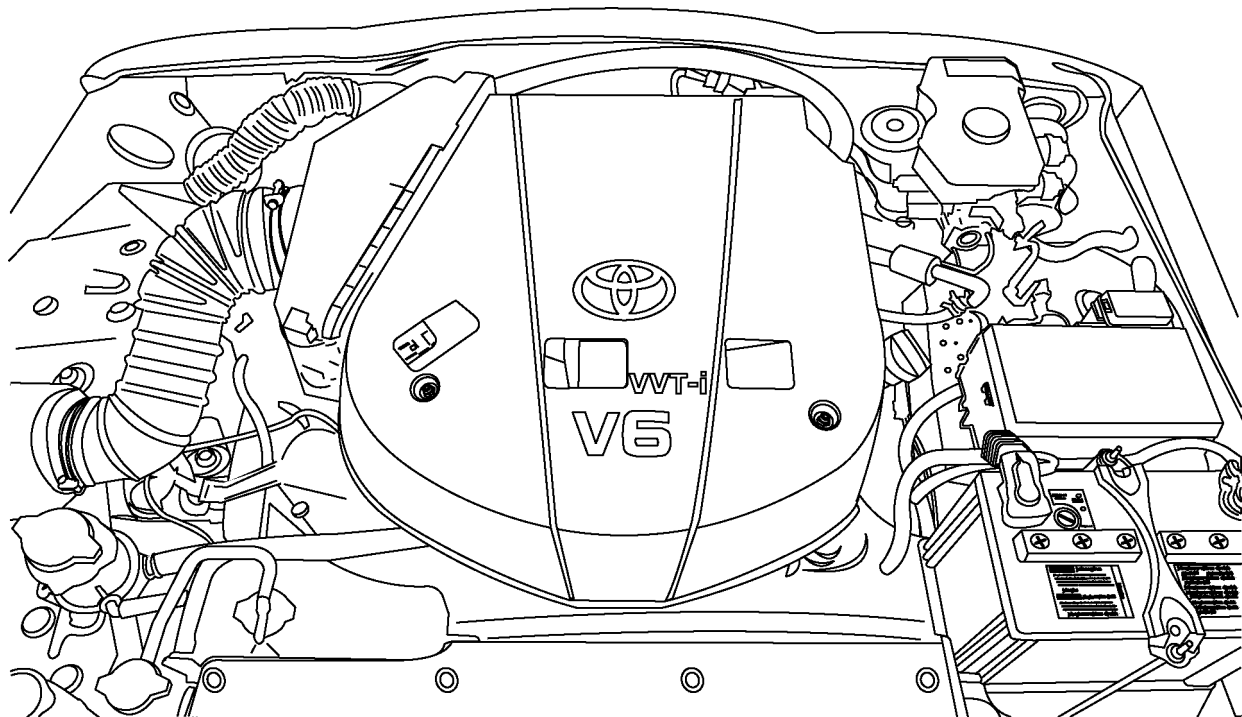

Fig. 3-02
TL623f302

Battery Type **Lead-Acid** - Virtually all automotive batteries are lead-acid batteries. Two different metals, both lead compounds, are immersed in an acid electrolyte. The chemical reaction produced provides electrical energy.

Low Maintenance/No Maintenance - Some manufacturers use this terminology. “Low maintenance” means that electrolyte can be added. “No maintenance” means that the battery is sealed.

Vented - Most batteries have removable vented caps that are used to check electrolyte level and add distilled water as necessary to restore the level. The caps also allow hydrogen gas, a byproduct of battery charging, to escape during charging.

Sealed - Some lead-acid batteries are sealed, that is, there are no removable caps to check electrolyte or replenish it. Some of these batteries have a small “eye” to indicate charge level. Still others are sealed, but include connections to external vent tubes.

NOTE For all types of batteries, always follow the manufacturers’ recommendations for charging and testing.

Lead-Acid Battery

Lead-acid batteries are called by different names: vented, sealed, low maintenance, and no maintenance.

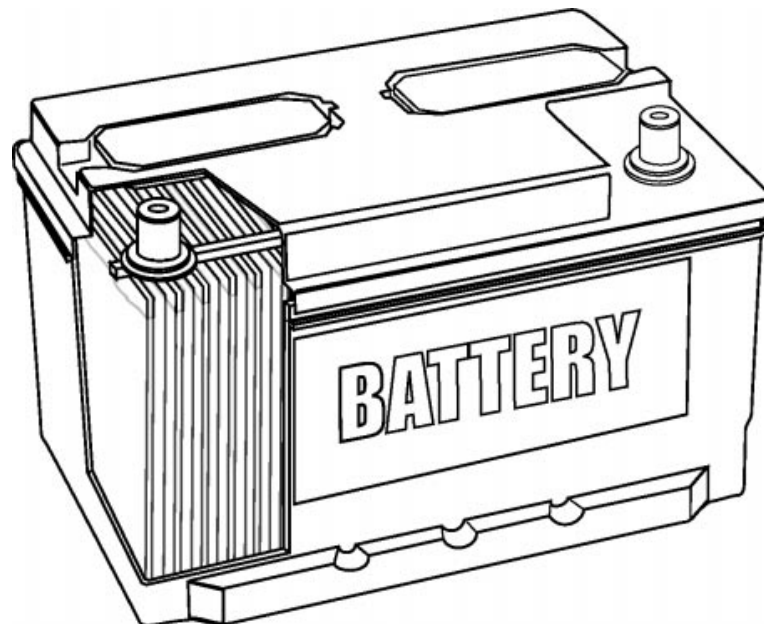

Fig. 3-03
TL623f300

Battery Construction

Battery Case

The battery case holds and protects all of the internal components and contains the electrolyte.

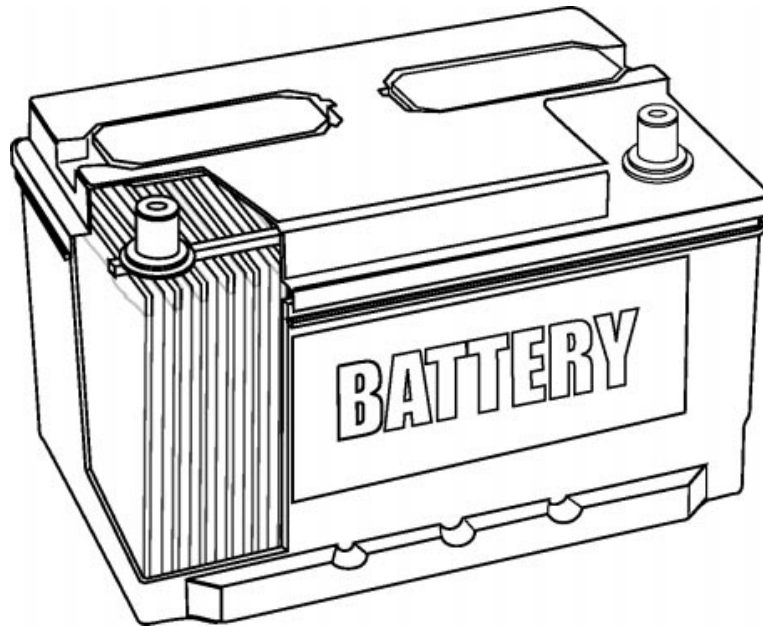

Fig. 3-04
TL623f300

Battery Case The battery case and cover...

- Form a sealed container.
- Protect the internal parts.
- Keep the internal parts in proper alignment.
- Prevent electrolyte leakage.

Plates Two types of plates are used in a battery: positive and negative.

Positive - Positive plates are made of antimony covered with an active layer of lead dioxide (PbO_2).

Negative - Negative plates are made of lead covered with an active layer of sponge lead (Pb).

Only the surface layers on both plates take part in the chemical reaction.

Plate surface area - As the surface area of the plates increases, so does the current capacity of the battery. Surface area is determined by the size of each plate, as well as the total number of plates in a battery. Generally speaking, the larger the battery, the higher is its current capacity.

Surface area has no effect on battery voltage.

Positive and Negative Plates

Positive plates are covered with lead dioxide (PbO_2); negative plates are made of lead (Pb).

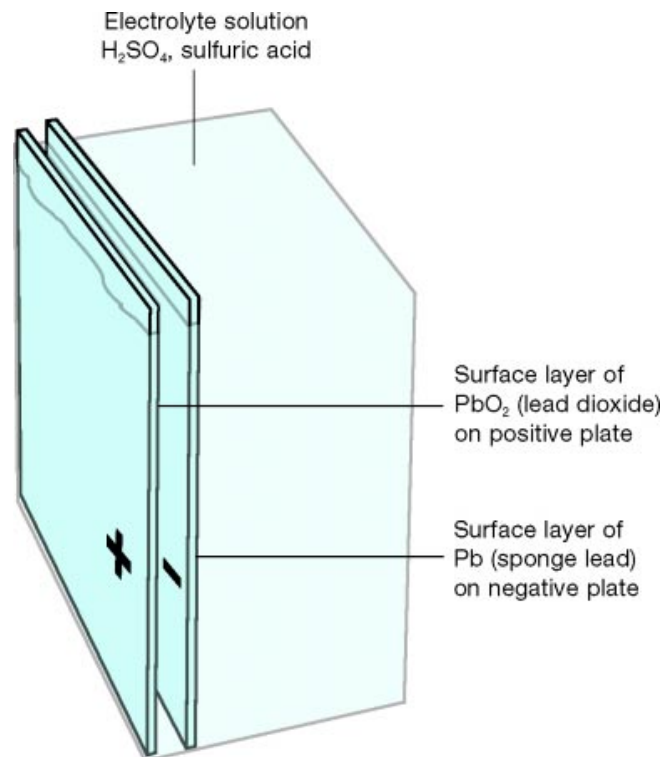

Fig. 3-05
TL623f305c

Separators The plates are separated by thin porous insulators. These allow electrolyte to pass freely between the plates, but prevent the plates from touching each other and shorting out.

Insulators

Insulator plates keep positive and negative plates from touching each other and shorting out.

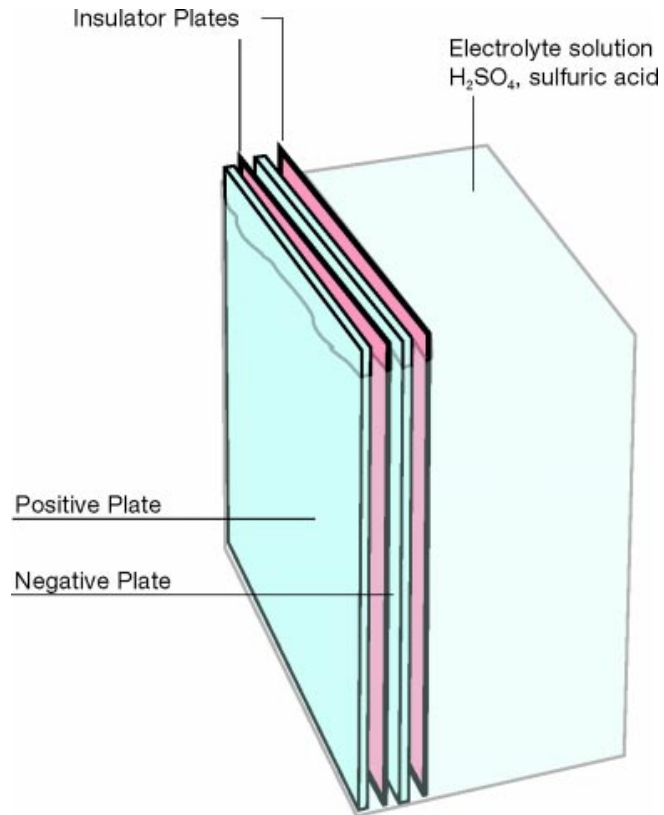

Fig. 3-06
TL623f306c

Cells A typical lead acid battery is organized into cells.

Each cell ...

- Consists of multiple positive and negative plates immersed in their own electrolyte reservoir.
- Produces about 2.1 volts, regardless of battery size.

Automotive batteries are rated at 12 volts. To make up this voltage, six cells, each producing 2.1 volts, are connected in series.

$$6 \times 2.1 \text{ volts} = 12.6 \text{ volts}$$

As a result, actual battery voltage is typically closer to 12.6 volts.

Cells are connected in series with heavy internal straps.

A positive and a negative terminal post provide connection points for the vehicle's battery cables.

Battery Cells

A typical automotive battery contains six cells connected in series. Each cell produces 2.1 volts.

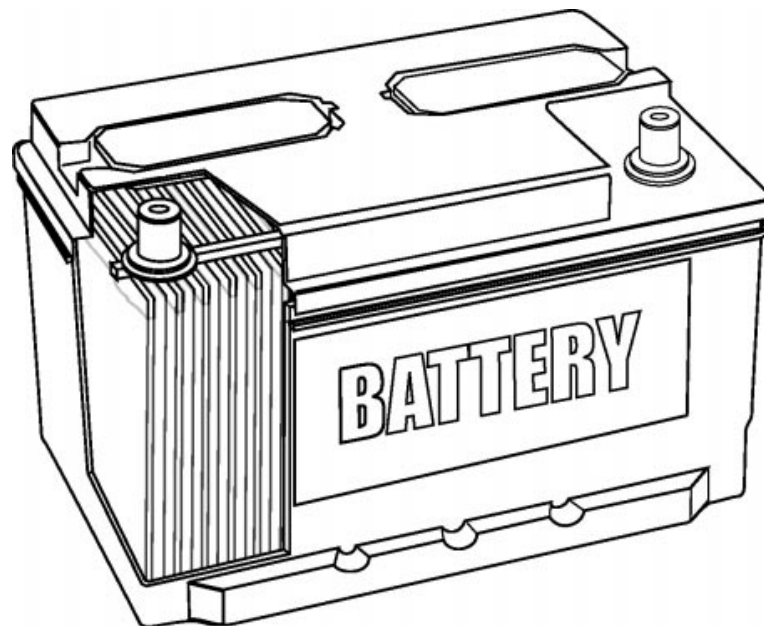

Fig. 3-07
TL623f307

Venting System On some batteries, vent caps allow a controlled release of hydrogen gas. This gas forms naturally during battery recharging, whether by the vehicle's alternator or by an external charger.

Battery Vent Caps

Vent caps allow the controlled release of hydrogen gas as the battery charges.

Electrolyte solution
 H_2SO_4 , sulfuric acid

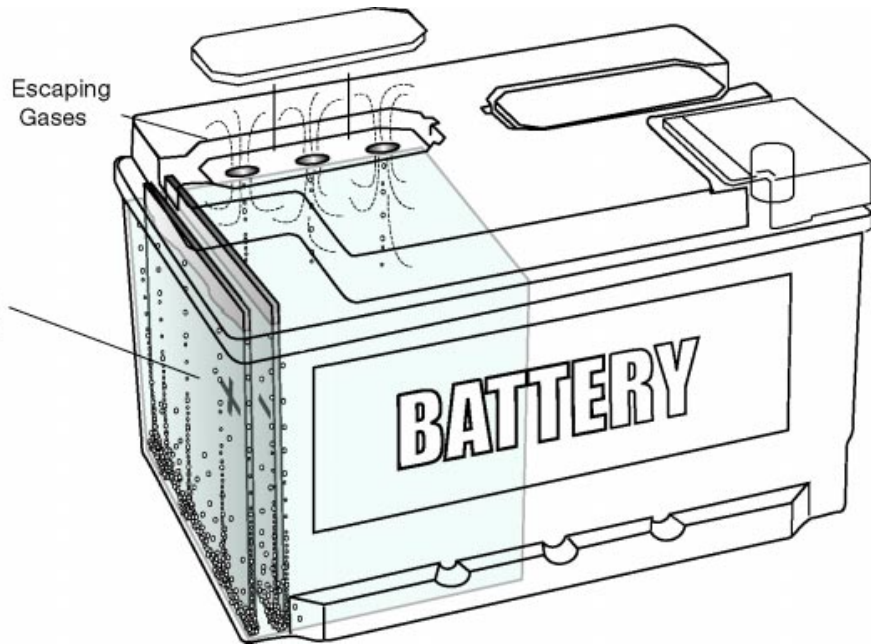

Fig. 3-08
TL623f308c

Electrolyte The electrolyte is a mixture of sulfuric acid (H_2SO_4) and water (H_2O). The electrolyte reacts chemically with the active material on the plates to produce a voltage (electrical pressure).

Battery Electrolyte

Acid in the electrolyte reacts chemically with the positive plate's lead oxide (PbO_2) and the negative plate's sponge lead (Pb) to produce a voltage.

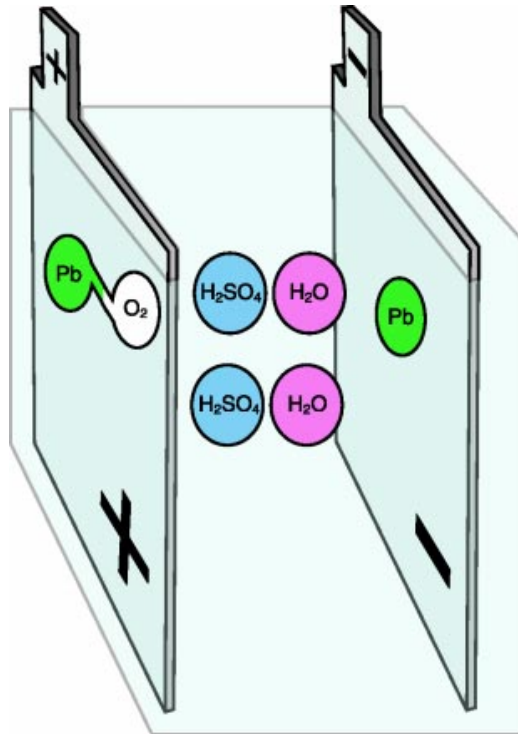

Fig. 3-09
TL623f309c

How Batteries Work The function of a lead acid cell is based on a simple chemical reaction. When two dissimilar metals are immersed in an acid solution, a chemical reaction produces a voltage. Using this reaction, a lead-acid battery can be discharged and charged many times.

There are four stages in the discharging-charging cycle:

- Fully Charged
- Positive plate covered with lead oxide (PbO_2).
 - Negative plate covered with sponge lead (Pb).
 - Electrolyte contains water (H_2O) and sulfuric acid (H_2SO_4).
- Discharging
- Current flows in the cell from the negative to the positive plates.
 - Electrolyte separates into hydrogen (H_2) and sulfate (SO_4).
 - The free sulfate combines with the lead (both lead oxide and sponge lead) and becomes lead sulfate (PbSO_4).
 - The free hydrogen and oxygen combine to form more water, diluting the electrolyte.
- Fully Discharged
- Both plates are fully sulfated.
 - Electrolyte is diluted to mostly water.
- Charging
- Reverses the chemical reaction that took place during discharging.
 - Sulfate (SO_4) leaves the positive and negative plates and combines with hydrogen (H_2) to become sulfuric acid (H_2SO_4).
 - Hydrogen bubbles form at the negative plates; oxygen appears at the positive plates.
 - Free oxygen (O_2) combines with lead (Pb) at the positive plate to become lead oxide (PbO_2).

Lead Acid Chemical Reaction

The charging-discharging cycle has four distinct stages, all based on a reversible chemical reaction with lead and sulfuric acid.

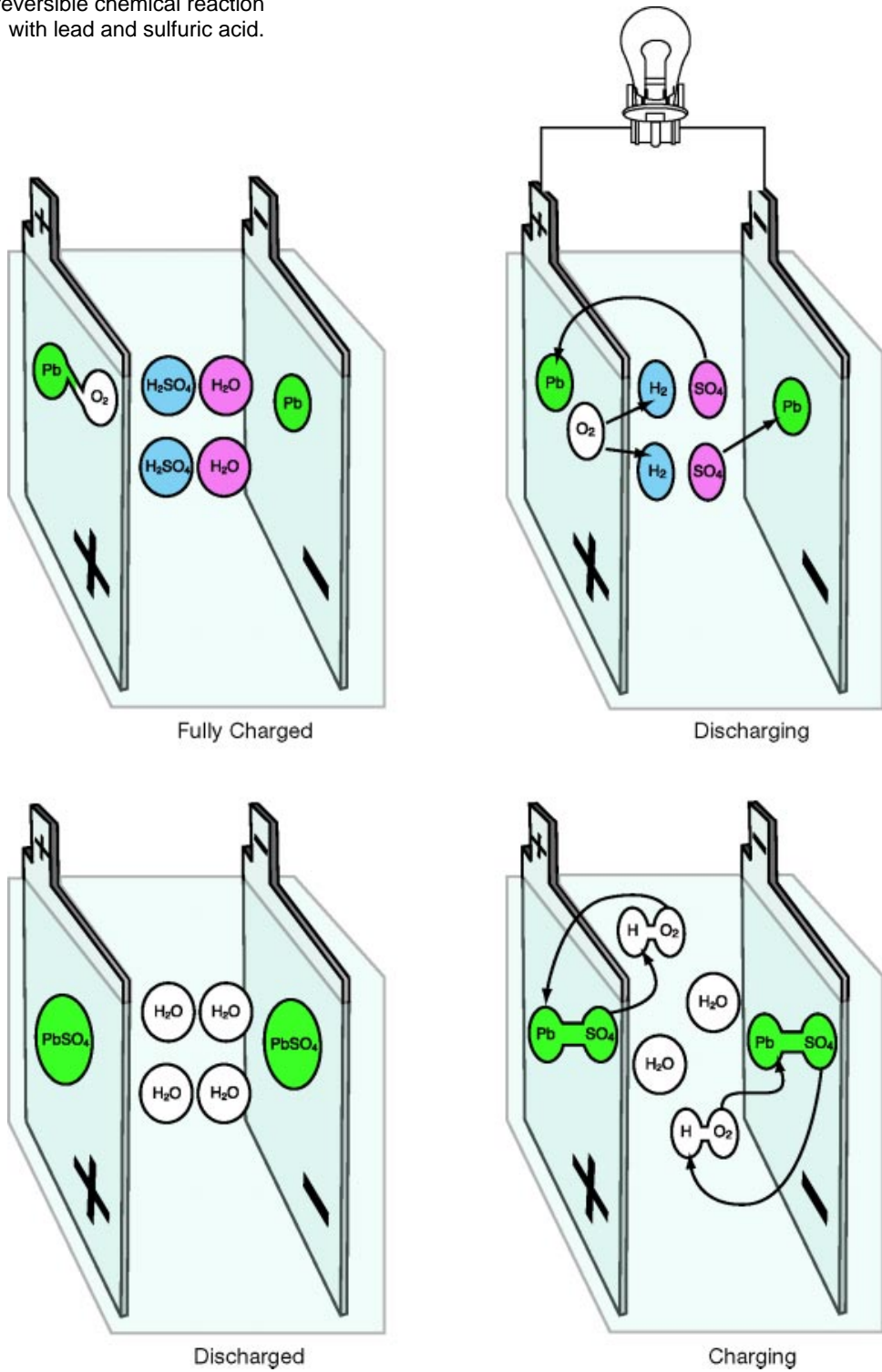

Fig. 3-10
TL623f310c

Capacity Ratings An automotive battery must be able to crank the engine for starting and still have enough reserve capacity to operate the vehicle systems once the engine starts.

Battery capacity is:

- The amount of electrical energy the battery can deliver when fully charged.
- Determined by the size and total number of plates and the volume and strength of the electrolyte.

Refer to the manufacturer's specification for information specific to a particular Toyota vehicle.

Cold-Cranking Amperes While it is operating the starter, the battery experiences a large discharge current.

The measure of a battery's ability to provide this current is expressed as Cold-Cranking Amperes, or CCA Rating.

The CCA Rating specifies (in amperes) the discharge current a fully charged battery can deliver ...

- at 0° F (-18° C),
- for 30 seconds,
- while maintaining at least 1.2 volts per cell (or 7.2 volts total for a six-cell, 12-volt battery).

Batteries in Toyota vehicles typically have a CCA rating between 350 to 560 amperes, depending on vehicle model. Refer to TIS to obtain information for specific Toyota vehicles.

Reserve Capacity (RC) The battery must provide reserve energy for the ignition system and for lights and accessories if the charging system fails.

The Reserve Capacity rating measures (in minutes) the amount of time a fully charged battery can ...

- discharge at 25 amperes, while maintaining a voltage of at least 1.75 volts per cell (total of 10.5 volts for a 6-cell, 12-volt battery).

Batteries in Toyota vehicles typically have an RC rating between 55 and 115 minutes, depending on vehicle model. Refer to TIS to obtain information for specific Toyota vehicles.

Ampere-Hours (AH) The Ampere-Hours, or AH rating, is another important measure of a battery's design performance.

The AH rating expresses the discharge current a fully charged battery can deliver for 20 hours ...

- at 80° F (27° C),
- while maintaining a voltage of at least 1.75 volts per cell (total of 10.5 volts for a 6-cell, 12-volt battery).

EXAMPLE A battery that can deliver 4 amps for 20 hours is rated at 80 amp-hours.

Batteries in Toyota vehicles typically have an AH rating between 40 and 80 amp-hours, depending on vehicle model. Refer to TIS to obtain information for specific Toyota vehicles.

Visual Inspection Battery service should always begin with a thorough visual inspection. Such an inspection may reveal simple, easily corrected problems or problems that require battery replacement without further testing.

Include these steps in a visual inspection:

1. Check for cracks in the battery case. Check particularly around battery terminals. These are sometimes overstressed when removing and installing battery cables. Replace the battery if there is any evidence of cracking.
2. Check for cracked or broken cables or connections. Replace cables or connectors as necessary.
3. Check for corrosion on terminals and dirt or acid on the case top. Clean the terminals and case top with a mixture of water and baking soda. Wire brush heavy corrosion on the terminals.
4. Check for a loose battery hold-down and loose cable connections. Tighten as needed.
5. On batteries with removable vent caps, remove the caps and check the electrolyte level. Add distilled water to each cell to restore the level if necessary. Avoid overfilling and never add additional acid. Tap water adds contaminants, and will reduce battery efficiency.

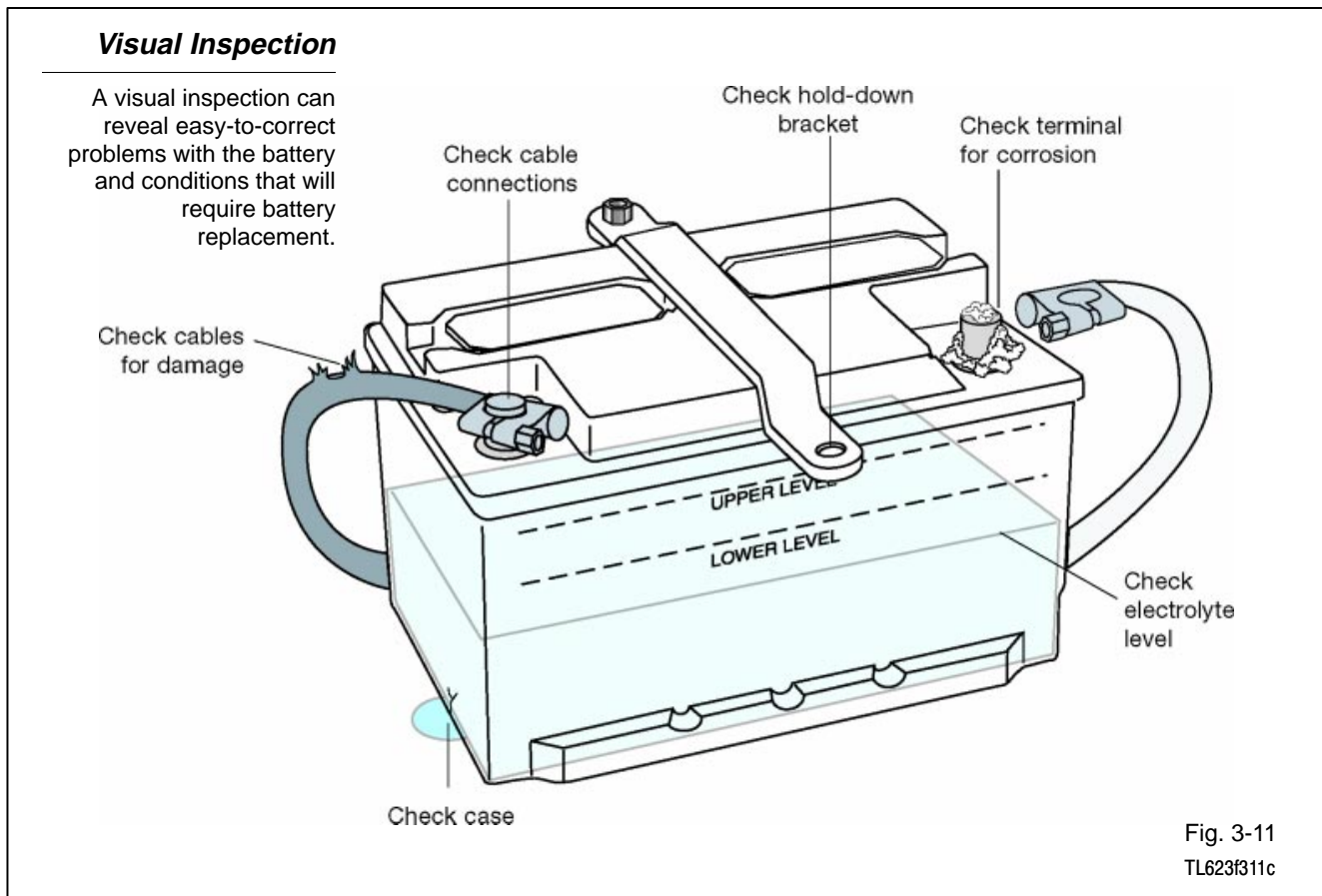

Battery Indicator Eye

The battery indicator eye can give a quick indication of battery condition.

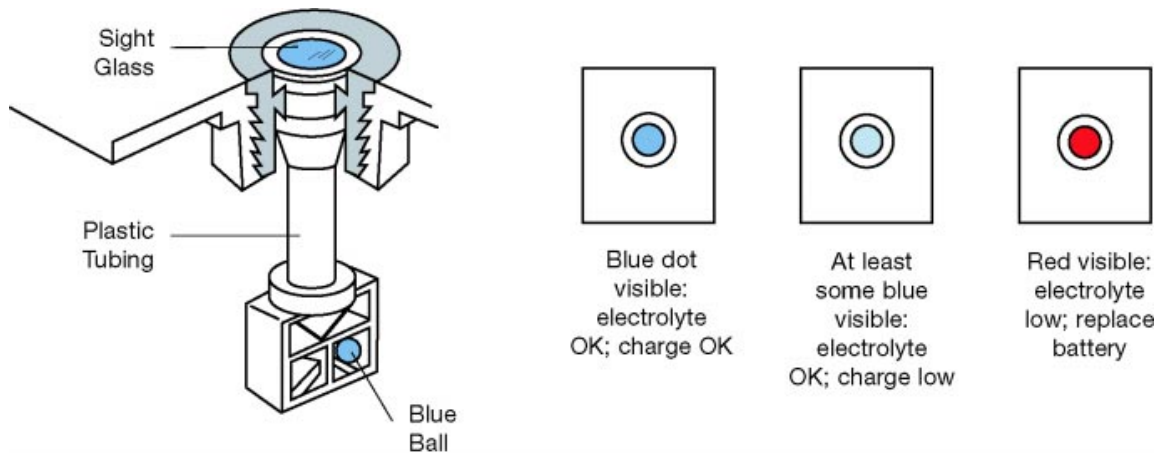

Fig. 3-12
TL623f312c

6. Check the indicator eye. A red eye indicates the battery is severely discharged or the electrolyte is low. The electrolyte level is sufficient and the battery is at least 25% charged if at least some blue is showing.
7. Check for cloudy or discolored electrolyte. This can be caused by overcharging or excessive vibration. Correct the problem and replace the battery.

Safety First Safety should be your first consideration whenever you inspect, test, or replace a lead acid battery. The electrolyte contains sulfuric acid. This acid can burn your skin, injure your eyes, and damage the vehicle, your tools, or your clothing.

If you splash electrolyte onto your skin or into your eyes, immediately rinse it away with large amounts of clean water. Contact a doctor immediately.

If you spill electrolyte onto any part of the vehicle, neutralize the acid with a solution of baking soda and water, then rinse liberally to remove any residue.

When a battery is charging, the electrolyte may release gasses (hydrogen and oxygen). Hydrogen gas is explosive, and oxygen supports combustion. A flame or spark near a charging battery can cause an explosion.

Precautions Take the following precautions when working with automotive batteries:

- Wear gloves and safety glasses.
- Never use spark-producing tools near the battery.
- Never lay any tools on the battery.
- If it is necessary to remove the battery cables, always remove the ground first.
- When connecting battery cables, always connect the ground cable last.
- Do not use the battery ground terminal when checking for ignition spark.
- Take care not to spill electrolyte into your eyes, onto your skin, and onto any part of the vehicle.
- If you mix electrolyte, pour the acid into the water (not the water into the acid).
- Always follow the recommended procedures for battery testing, charging, and for connecting jumper cables between two batteries.

Battery Drain Tests There are two tests for battery drain:

1. Parasitic load
2. Surface discharge

A parasitic load is created by a device that draws current even when the ignition switch is turned to “Off.” Even a small current can discharge the battery, if the vehicle is not used for an extended time.

Check for a parasitic load as follows:

1. Connect an ammeter in series between the battery negative terminal and the ground cable connector.
2. Select the appropriate scale and read the current draw.
3. Toyota vehicles typically draw between 20 and 75 milliamps (this is current used to maintain electronic memories).
4. Any reading higher than 100 milliamps is unacceptable. Locate and correct the cause of the excess parasitic drain.
5. Make sure that you wait a few minutes before checking for parasitic load. After the vehicle is shut down or a door is opened, parasitic load may be 50-75 milliamps, depending on model, for a few minutes.

Surface discharge is a small current that runs between the two battery terminals, across the surface of the battery. This can occur only when that surface is dirty.

Check for surface discharge as follows:

1. Connect a voltmeter, black test lead (negative) to the battery's negative terminal; red test lead (positive) to the top of the battery case.
2. Select an appropriate scale and read the voltage.
3. If the meter reading is higher than 0.5 volts, clean the case top with a solution of baking soda and water.

Two Tests for Battery Drain

Parasitic load current and battery surface discharge can cause batteries to discharge over time.

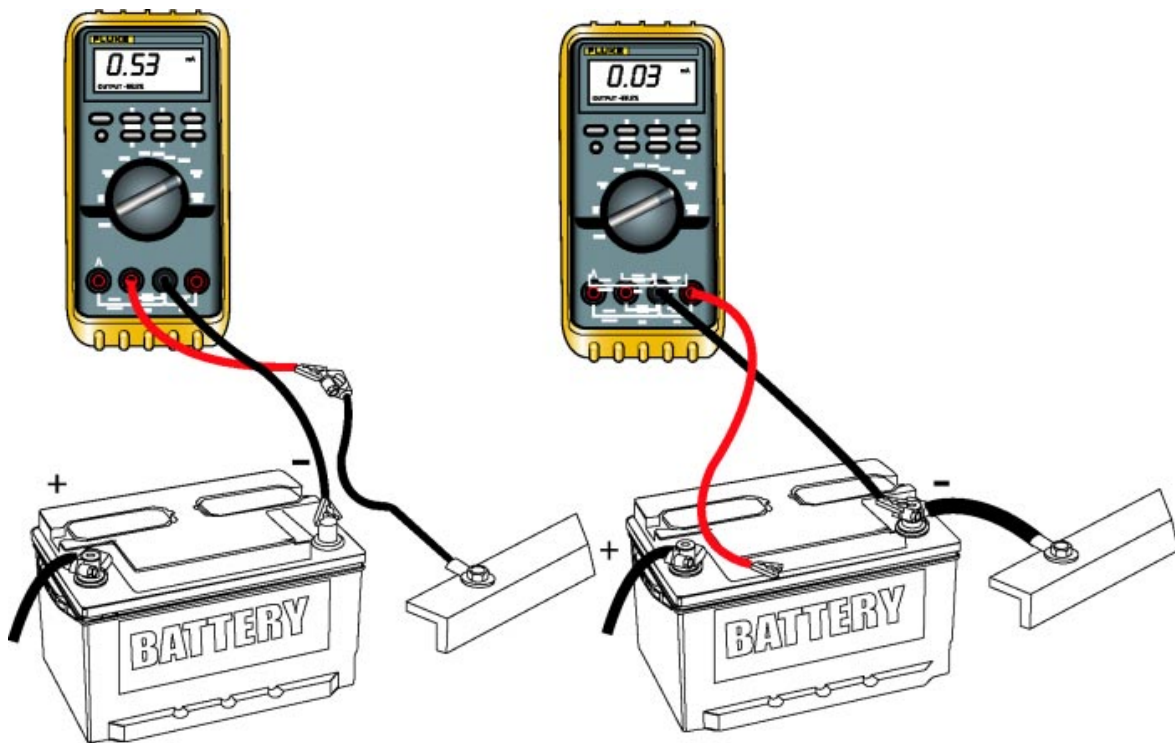

Fig. 3-13
TL623F313c

Micropro 815 Battery Analyzer

You can use a battery analyzer to obtain an indication of battery condition that is more accurate than just its state of charge. The Midtronics Micropro 815 Battery Analyzer uses conductance testing to evaluate the condition of the plates inside the battery.

There are several advantages of using this battery analyzer:

- Battery can be tested even when it's not fully charged.
- No need to charge battery before testing; can be tested as soon as vehicle arrives for service.
- Information from analyzer lets you make a quick decision.
- Reduces costly mistakes.

Micropro 815 Battery Analyzer

A battery analyzer can help you make a quick and accurate determination of battery condition.

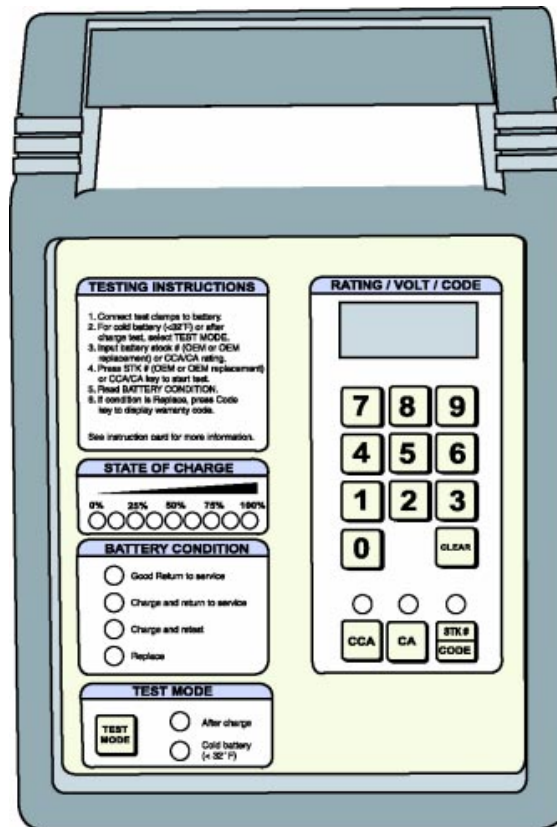

Fig. 3-14
TL623f314c

Preparing the Battery for Analyzer Tests

Prepare the battery for testing:

- Remove the battery's surface charge.
- Disconnect the battery from the vehicle.
- Make sure the terminals are clean and free of corrosion.
- If the battery has removable vent caps, check the electrolyte level. Top up with distilled water if needed.

To remove a battery's surface charge, turn on the headlights with the engine off. Leave the lights on for one minute.

You can test batteries either connected to or disconnected from the vehicle. In general, you get more reliable results with the battery disconnected. If you do leave the battery connected for testing, turn off all lights and accessories and set the ignition switch to the OFF position.

Preparing the Battery

To get the most accurate results, make sure the battery terminal posts are clean for testing.

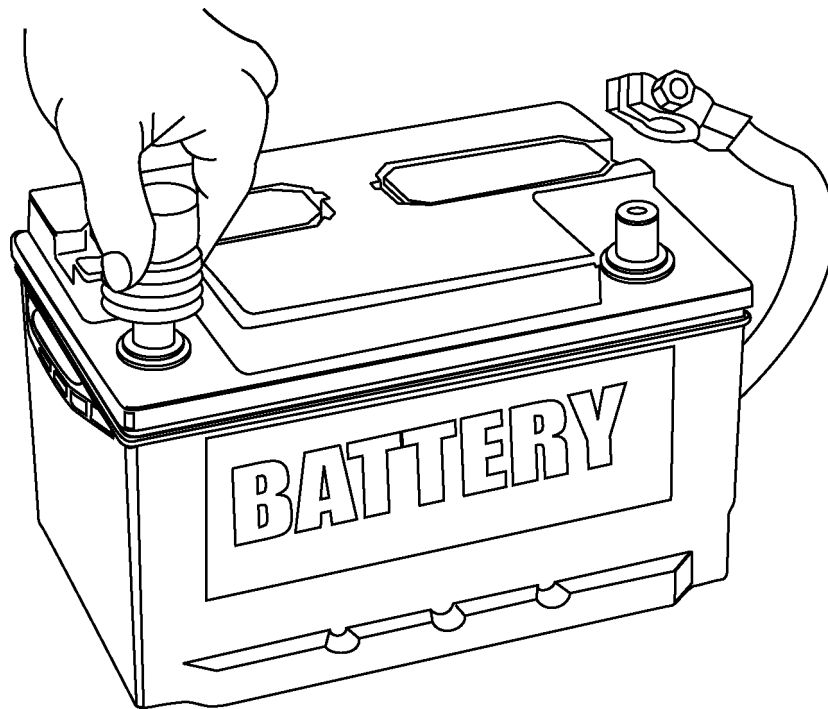

Fig. 3-15
TL623F315

Setting Up the Battery Analyzer

Set up the battery analyzer as follows:

1. Connect the analyzer's red lead to the positive battery terminal.
2. Connect the black lead to the negative battery terminal.
3. Check the analyzer's display. It should illuminate and show four zeros to indicate a good connection. The analyzer's display will not illuminate if there is a poor connection.

Connections - The teeth on both sides of each clamp must contact the battery terminal. Rock both clamps back and forth to ensure a good electrical connection.

4. Proceed to Testing the Battery (on the next page) if you have not charged the battery before test.
5. Press the Test Mode key once if you charged the battery before the test. The "After Charge" LED will light.

Press the Test Mode key twice if battery temperature is 32° F (0° C) or lower. The "Cold Battery" LED will light.

Analyzer Test Connections

The battery analyzer's clamp teeth must contact the battery terminal post on both sides.

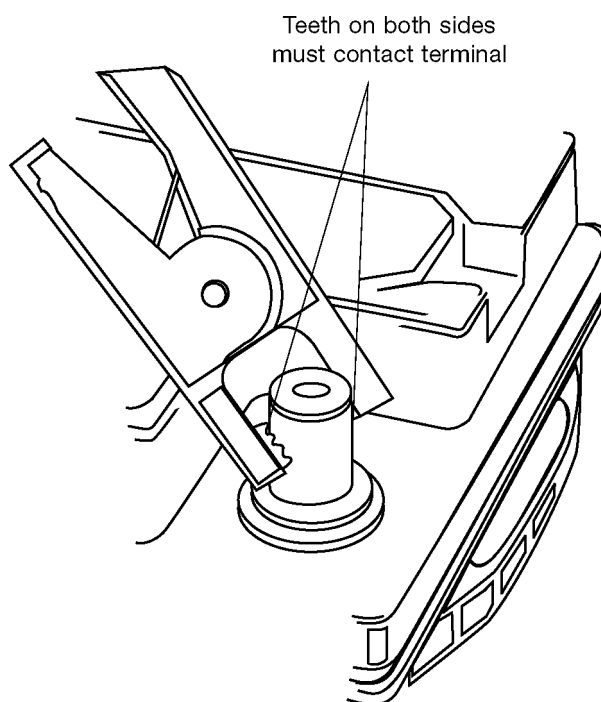

Fig. 3-16
TL623f316

Testing the Battery Use these steps to test an original equipment battery or OE replacement:

1. Select the correct STK# from the chart included with the tester (in the flap of the soft case).

NOTE

A valid STK# is a requirement for warranty testing. Updated charts can be found on TIS.

2. Use the analyzer's keypad to enter the 4-digit STK#.
3. Press the STK# key to start the test.

Testing the Battery

This table is enclosed with the Midtronics Battery Analyzer.



To test a Toyota OE or Toyota Interstate OE Replacement battery, input the STK# listed below and press the STK#/Code key to begin test. To test all other batteries, locate the battery's CCA or CA rating located on the battery label, and input the number using the keypad. Begin the test by pressing the CCA key if using the CCA rating or CA key if using the CA rating. If testing a Lexus OE or Lexus Interstate OE Replacement battery, refer to the testing instructions on the reverse side of this card.

TOYOTA OE BATTERY					INTERSTATE OE REPLACEMENT			
Model	OE STK#	CCA	Group Size	Supplier	REPL STK#	CCA	Group Size	Supplier
Avalon	2458	582	80D26L	JCI, GNB	2460	575	24F	INTERSTATE
Avalon	5523	356	55D23L	JCI, GNB	3560	550	35	INTERSTATE
Camry (USA)	2458	582	80D26L	JCI, GNB	2460	575	24F	INTERSTATE
Camry (Japan) ≤ 2001	5523	356	55D23L	JCI, GNB	3560	550	35	INTERSTATE
Camry (Japan)	8026	582	80D26L	PANASONIC	2460	575	24F	INTERSTATE
Celica ≤ 1999	5523	356	55D23L	PANASONIC	3560	550	35	INTERSTATE
Celica ≤ 1999	6523	420	65D23L	PANASONIC/YUASA	3560	550	35	INTERSTATE
Celica	5020	306	50D20L	PANASONIC	3560	550	35	INTERSTATE
Celica (cold pkge)	5523	356	55D23L	PANASONIC	3560	550	35	INTERSTATE
Corolla (Canada) ≤ 2002	3531	356	55D23L	DELCO / DELPHI	3560	550	35	INTERSTATE
Corolla (NUMM) ≤ 2002	3531	356	35	DELCO / DELPHI	3560	550	35	INTERSTATE
Corolla	3531	356	55D23L	DELPHI	3560	550	35	INTERSTATE
Corolla / Matrix	3531	356	55D23L	DELPHI	3560	550	35	INTERSTATE
Paseo	5020	306	50D20R	PANASONIC	2560	550	25	INTERSTATE
Paseo (cold pkge)	5523	356	55D23R	PANASONIC	2560	550	25	INTERSTATE
Tercel	5020	306	50D20R	PANASONIC	2560	550	25	INTERSTATE
Tercel (cold pkge)	5523	356	55D23R	PANASONIC	2560	550	25	INTERSTATE
Supra A/T	8026	582	80D26L	PANASONIC	2460	575	24F	INTERSTATE
Supra M/T	7526	490	75D26L	PANASONIC	2460	575	24F	INTERSTATE
Echo	5020	306	50D20R	PANASONIC	2560	550	25	INTERSTATE
Echo (cold pkge)	6523	420	65D23R	PANASONIC	2560	550	25	INTERSTATE
Tacoma 4X2	3531	356	55D23L	DELCO	3560	550	35	INTERSTATE
Tacoma 4X2 (cold pkge)	2455	582	80D26L	DELCO	2460	575	24F	INTERSTATE
Tacoma 4X4	2455	582	80D26L	DELCO	2460	575	24F	INTERSTATE
Tacoma 4X4	3531	356	55D23L	DELCO	3560	550	35	INTERSTATE
Tacoma 4X4 (cold pkge)	2455	582	80D26L	DELCO	2460	575	24F	INTERSTATE
4Runner	8026	582	80D26L	PANASONIC	2460	575	24F	INTERSTATE
4Runner (cold pkge)	9531	622	95D31L	PANASONIC	2761	675	27F	INTERSTATE
4Runner	5523	356	55D23L	PANASONIC	3560	550	35	INTERSTATE
4Runner (cold pkge)	8026	582	80D26L	PANASONIC	2460	575	24F	INTERSTATE
Highlander	8026	582	80D26L	PANASONIC	2460	575	24F	INTERSTATE
Land Cruiser (cold pkge)	0531	710	105D31L	PANASONIC	2771	710	27F	INTERSTATE
Land Cruiser	2455	582	80D26L	PANASONIC	2460	575	24F	INTERSTATE
MR2 Spider	5524	433	55B24L	PANASONIC	3560	550	35	INTERSTATE
Previa	5523	356	55D23L	PANASONIC	3560	550	35	INTERSTATE
Previa S/C	8026	582	80D26L	PANASONIC	2460	575	24F	INTERSTATE
Prius	3420	272	S34B20L	GS NIPPON DENCHO	NONE	NONE	NONE	NONE
T100	2455	550	80D26L	DELCO	2460	575	24F	INTERSTATE
RAV4	4624	325	46B24L	FURUKAWA	3560	550	35	INTERSTATE
RAV4 (cold pkge)	5523	356	55D23L	FURUKAWA, YUASA	3560	550	35	INTERSTATE
Sequoia	0531	710	105D31L	JCI, GNB	2771	710	27F	INTERSTATE
Sienna	2458	582	80D26L	JCI, GNB	2460	575	24F	INTERSTATE
Solara	2458	582	80D26L	JCI, GNB	2460	575	24F	INTERSTATE
Solara	5523	356	55D23L	JCI, GNB	3560	550	35	INTERSTATE
Tundra 5VZ-FE	5523	356	55D23L	JCI, GNB	3560	550	35	INTERSTATE
Tundra 5VZ-FE (cold pkge)	2458	582	80D26L	JCI, GNB	2460	575	24F	INTERSTATE
Tundra 2UZ-FE	2458	582	80D26L	JCI, GNB	2460	575	24F	INTERSTATE
Tundra 2UZ-FE (cold pkge)	0531	710	105D31L	JCI, GNB	2771	710	27F	INTERSTATE

Updated: May 2002

MIDTRONICS P/N 168-475C-T

Fig. 3-17
TL623F317

Use these steps to test a non-OE battery.

For battery with CCA rating:

1. Find the CCA (cold-cranking amps) rating on the battery label.
2. Enter the rating number via the keypad.
3. Press the CCA key to start the test.

For battery with a CA (cranking amps) rating:

1. Find the CA rating on the battery label.
2. Enter the rating number via the keypad.
3. Press the CA key to start the test.

Use this procedure if you cannot determine any usable rating for a battery to be tested:

1. Find an STK# on the chart that is recommended for the vehicle in which the battery is installed.
2. Use the analyzer's keypad to enter the 4-digit STK#.
3. Press the STK# key to start the test.

Interpreting the Results

The results will be displayed in the Battery Condition area of the panel.

Good return to service - The battery is in good condition and ready to return to service.

Charge and return to service - The battery is good, but must be fully charged before returning to service.

Charge and retest - The test result is inconclusive. "Quick Charge" the battery and retest using the After Charge test mode.

Replace - The battery must be replaced. Press the STK#/CODE key to show the warranty code for the repair order.

Interpreting the Results

The battery analyzer lights one of these LED's to tell you the battery condition.

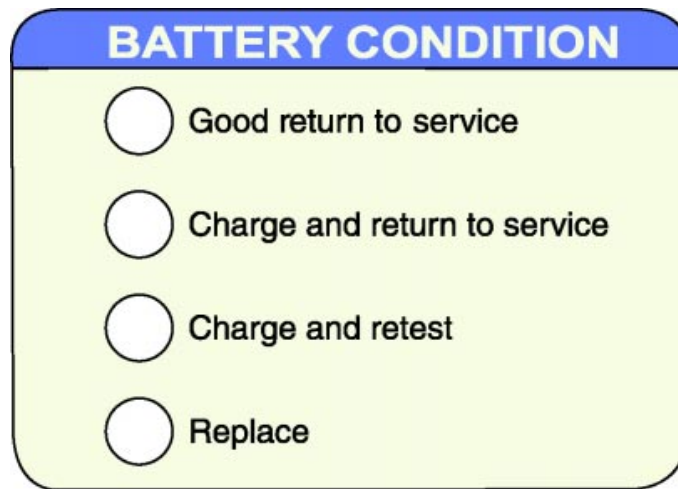

Fig. 3-18
TL623F318c

Fast Charging Fast charging is used to charge the battery for a short period of time with a high rate of current. Fast charging may shorten battery life. If time allows, **slow charging is preferred**. Some low maintenance batteries cannot be fast charged.

1. Preparation for charging:
 - Clean dirt, dust, or corrosion off the battery; if necessary, clean the terminals.
 - Check the electrolyte level and add distilled water if needed.
 - If the battery is to be charged while on the vehicle, be sure to disconnect both (-) (+) terminals.
2. Determine the charging current and time for fast charging:
 - Some chargers have a test device for determining the charging current and required time.
 - If the charger does not have a test device, refer to the chart to determine current and time.

Typical Charging Rates for Fully Discharged Batteries						
Reserve Capacity Rating	20-Hour Rating	5 Amperes	10 Amperes	20 Amperes	30 Amperes	40 Amperes
75 Minutes or less	50 Ampere-Hours or less	10 Hours	5 Hours	2½ Hours	2 Hours	
Above 75 to 115 Minutes	Above 50 to 75 Ampere-Hours	15 Hours	7½ Hours	3¼ Hours	2½ Hours	2 Hours
Above 115 to 160 Minutes	Above 75 to 100 Ampere-Hours	20 Hours	10 Hours	5 Hours	3 Hours	2½ Hours
Above 160 to 245 Minutes	Above 100 to 150 Ampere-Hours	30 Hours	15 Hours	7½ Hours	5 Hours	3½ Hours

3. Using the charger:
 - Make sure that the main switch and timer switch are OFF and the current adjust switch is at the minimum position.
 - Connect the positive lead of the charger to the battery's positive terminal (+) and the negative lead of the charger to the battery's negative terminal (-).
 - Connect the charger's power cable to the electric outlet.
 - Set the voltage switch to the correct battery voltage.
 - Set the main switch at ON.
 - Set the timer to the desired time and adjust the charging current to the predetermined amperage.

4. After the timer is OFF, check the charged condition using a voltmeter.
 - Correct Voltage: 12.6 volts or higher.

If the voltage does not increase, or if gas is not emitted no matter how long the battery is charged, there may be a problem with the battery, such as an internal short.

5. When the voltage reaches the proper reading,
 - Set the current adjust switch to minimum.
 - Turn off the main switch of the charger.
 - Disconnect the charger cable from the battery terminals.
 - Wash the battery case to clean off the acid emitted.

Slow Charging High charging rates are not good for completely charging a battery. To completely charge a battery, slow charging with a low current is required.

Slow charging procedures are the same as those for fast charging, except for the following:

1. The maximum charging current should be less than 1/10th of the battery capacity. For instance, a 40 AH battery should be slow charged at 4 amps or less.
2. Set the charger switch to the slow position (if provided).
3. Readjust the current control switch, if needed, while charging.
4. As the battery gets near full charge, hydrogen gas is emitted. When there is no further rise in battery voltage for more than one hour, the battery is completely charged.
 - Battery Voltage: 12.6 volts or higher.

Jump Starting Jump starting requires proper battery connecting procedures to prevent sparks. Jump start a vehicle using the following procedure:

1. Connect the two positive cables using the positive jumper leads.
2. Connect one end of the negative jumper lead to the booster battery.
3. Connect the other lead of the negative jumper lead to a good ground on the vehicle with the dead battery. This location could be:
 - The vehicle frame.
 - The engine block.

Using this method ensures that any possible sparks occur away from the battery.

NOTE Battery jumper leads should be high quality and have a large wire gauge (such as 4 gauge) to safely carry the current necessary to jump start a vehicle.

CAUTION Never try to jump start a vehicle with a visibly damaged battery or if no battery is present. Vehicle damage and risk of battery explosion are possible.

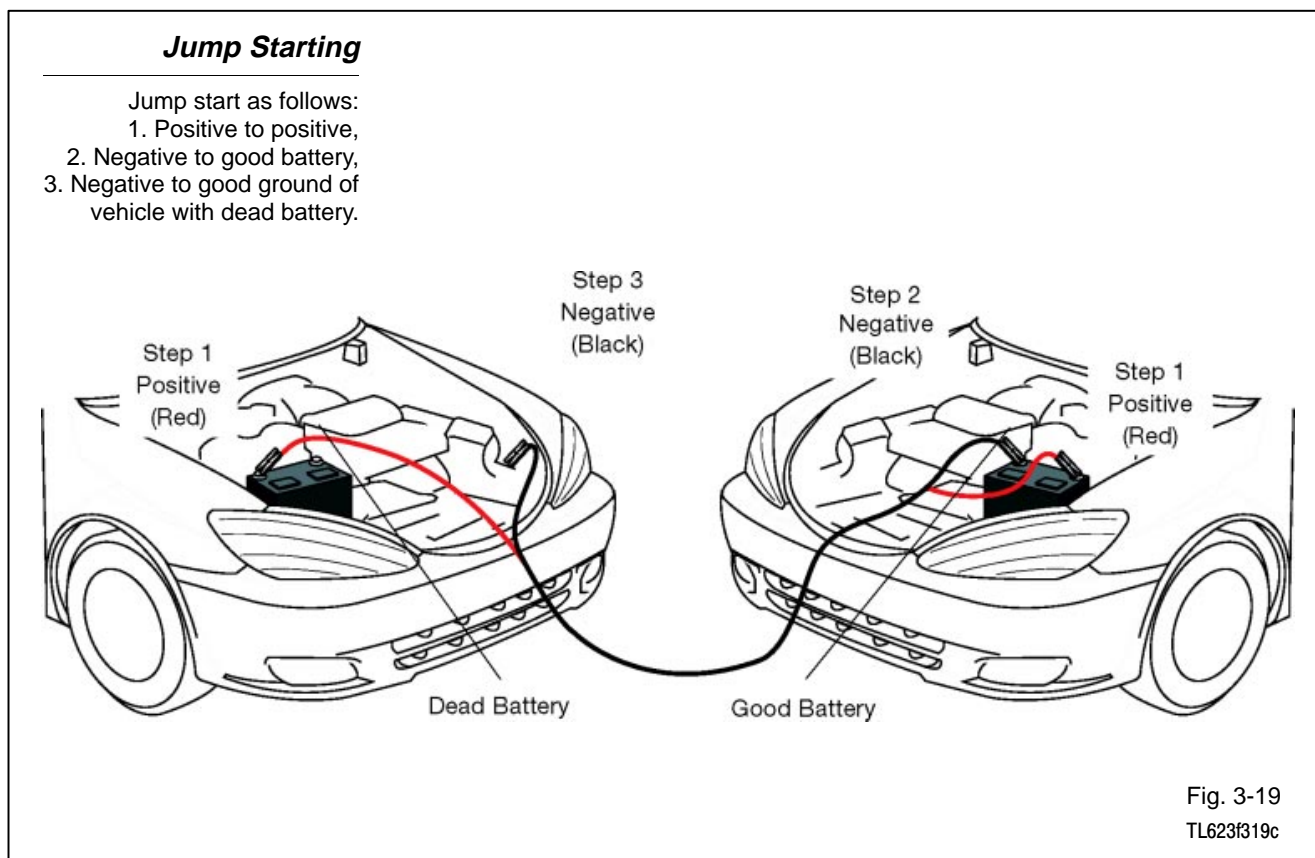



Notes



WORKSHEET 3-1
Battery Components

Worksheet Objectives

When you have completed this worksheet, you will be able to identify and name the components that make up a typical automotive battery.

Tools and Equipment

For this exercise you will need the following:

- Technician's Handbook

Exercise 1: Identifying and Naming the Components of a Battery

Refer to the drawing of a battery in Figure 3W1-1. Match the numbers on the drawing to the correct component names below:

1. _____
2. _____
3. _____
4. _____
5. _____
6. _____
7. _____

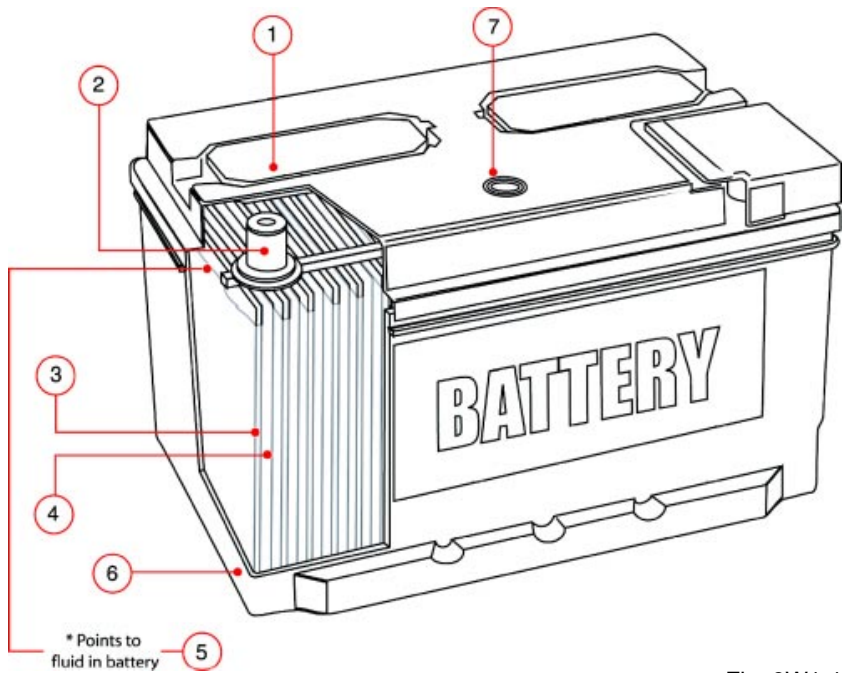

Fig. 3W1-1
TL623f001-3W1

Exercise 2: Associating Battery Component and Function

Refer to the list you made in Exercise 1. Match each of these functions with the associated component. Write the component's number in front of the function statement:

- _____ Allows checking of the battery's electrolyte level and state of charge.
- _____ Provides a connection point for the battery cable.
- _____ Separates and insulates battery plates from each other.
- _____ Is a mixture of sulfuric acid and water.
- _____ Houses and protects all the internal components and electrolyte.
- _____ Can be removed to add water to the electrolyte.
- _____ Is made of lead and takes part in the chemical reaction that produces electricity.

Battery Components

Name: _____ Date: _____

Review this sheet as you are doing the Battery Components worksheet. Check each category after viewing the instructor's presentation and completing the worksheet. Ask the instructor if you have questions regarding the topics provided below. Additional space is provided under topic for you to list any other concerns that you would like you instructor to address. The comments section is provided for your personal comments, information, questions, etc.

I have questions

I know I can

Topic	Comment		
Identify Battery Components			
Associate Components with their Function			



Notes



WORKSHEET 3-2
Battery Visual Inspection and Using the Battery Analyzer

Vehicle	Year/Prod. Date	Engine	Transmission
---------	-----------------	--------	--------------

Worksheet Objectives

In this worksheet, you will practice performing a visual inspection of the battery on an actual vehicle. When you have completed these exercises, you will be able to demonstrate the proper use of the approved battery tester.

Tools and Equipment

For this exercise you will need the following:

- Technician’s Handbook
- Vehicle
- MicroPro Battery Analyzer
- Battery
- Eye protection
- Access to TIS (PG017-02).

Exercise 1: Visual Inspection

Inspect each component on the list; describe the condition of each item in the table below:

Inspection Item	Condition
Positive battery cable	
Negative battery cable	
Positive battery terminal	
Negative battery terminal	
Battery case	
Hold-down bracket	
Electrolyte	

Exercise 2: Setting up the Battery Analyzer

Your instructor will provide you with a battery to test (this should be a Toyota battery).

Set up the battery analyzer as follows:

1. Connect the analyzer's red lead to the positive battery terminal.
2. Connect the black lead to the negative battery terminal.
3. Check the analyzer's display. It should illuminate and show four zeros to indicate a good connection. The analyzer's display will not illuminate if there is a poor connection.

Connections - The teeth on both sides of each clamp must contact the battery terminal. Rock both clamps back and forth to ensure a good electrical connection.

4. Proceed to Testing the Battery (on the next page) if you have not charged the battery before test.
5. Press the Test Mode key once if you charged the battery before the test. The "After Charge" LED will light.

Press the Test Mode key twice if battery temperature is 32°F (0°C) or lower.

The "Cold Battery" LED will light.

Exercise 3: Test the Battery

Use the following steps to test the Toyota OEM battery.

1. Select the correct STK# from the chart included with the tester (in the flap of the soft case).
 - Can also be found on T.I.S.
 - Go to T.I.S. home page
 - Click on "Diagnostics"
 - Click on "Midronics Battery Tester Software"
 - Click on "Toyota Stock Number Chart"

Note: A valid STK# is a requirement for warranty testing.

2. Use the analyzer's keypad to enter the 4-digit STK#.
3. Press the STK#/CODE key to start the test.
4. Note the result on the analyzer display and record it here:

5. What would you do if the analyzer display showed "REPLACE?"

Battery Visual Inspection and Using the Battery Analyzer

Name: _____ Date: _____

Review this sheet as you are doing the Battery Visual Inspection and Using the Battery Analyzer worksheet. Check each category after viewing the instructor's presentation and completing the worksheet. Ask the instructor if you have questions regarding the topics provided below. Additional space is provided under topic for you to list any other concerns that you would like your instructor to address. The comments section is provided for your personal comments, information, questions, etc.

I have questions

I know I can

Topic			Comment
Battery Visual Inspection			
Use of Battery Tester			



Notes

The Starting System

Starter

The starter motor drives the engine through a pinion gear that engages the ring gear on the flywheel.

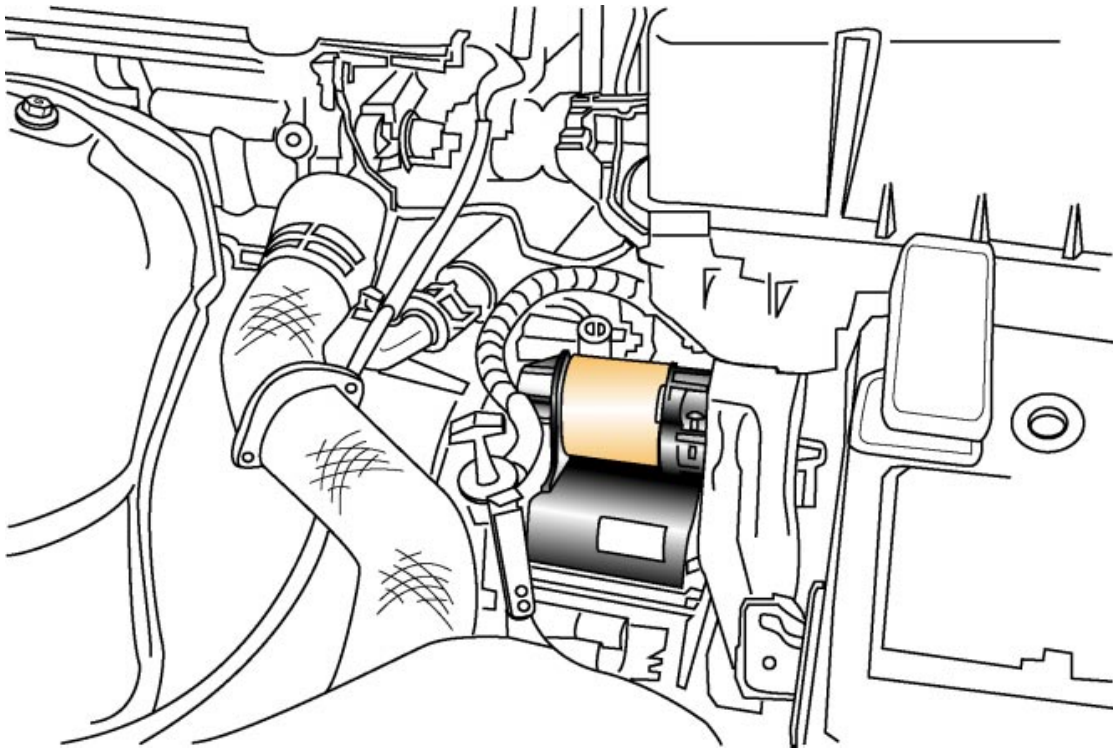

Fig. 4-01
TL623f401c

Starting System Overview

The starting system:

- Uses a powerful electric motor to drive the engine at about 200 RPM (fast enough to allow the fuel and ignition systems to operate).
- Drives the engine through a pinion gear engaged with a ring gear on the flywheel.
- Disengages as soon as the engine starts.

Starting System Components

These components make up a typical Toyota starting system:

- Starter motor
- Magnetic switch
- Over-running clutch
- Ignition switch contacts
- Park/neutral position (A/T) or clutch start (M/T) switch
- Clutch start cancel switch (on some models)
- Starter relay

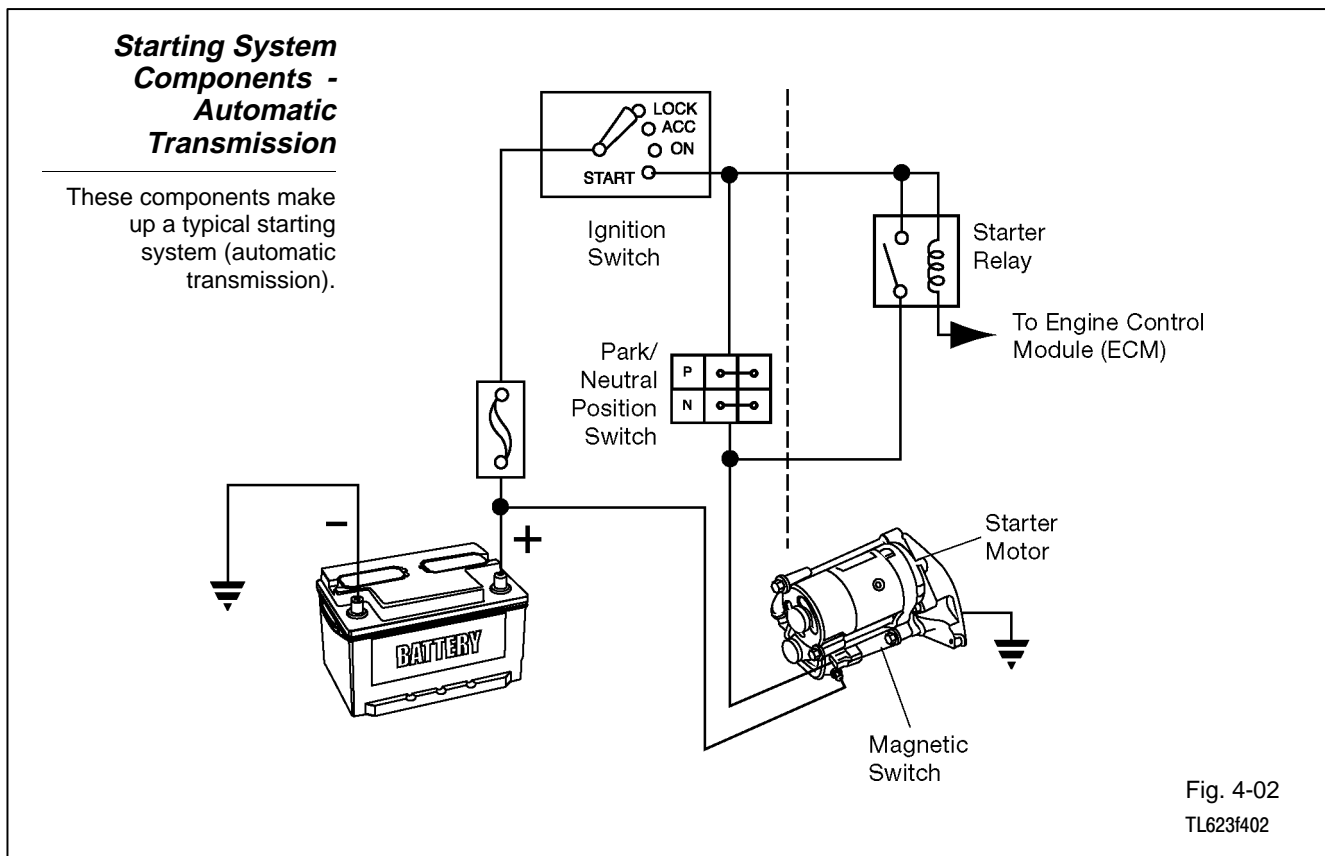

**Starting System
Components -
Manual
Transmission**

These components make up a typical starting system (manual transmission).

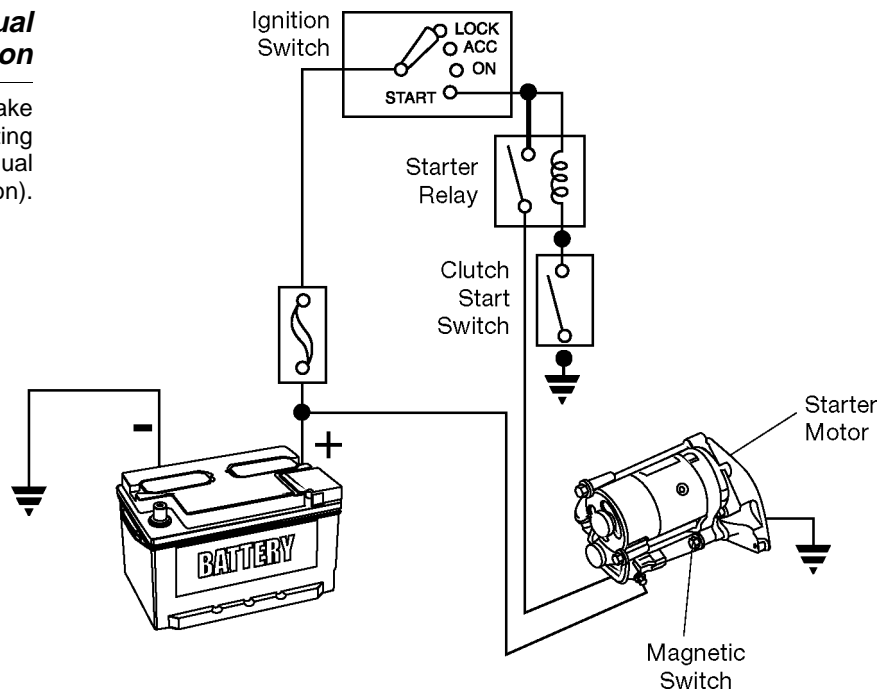
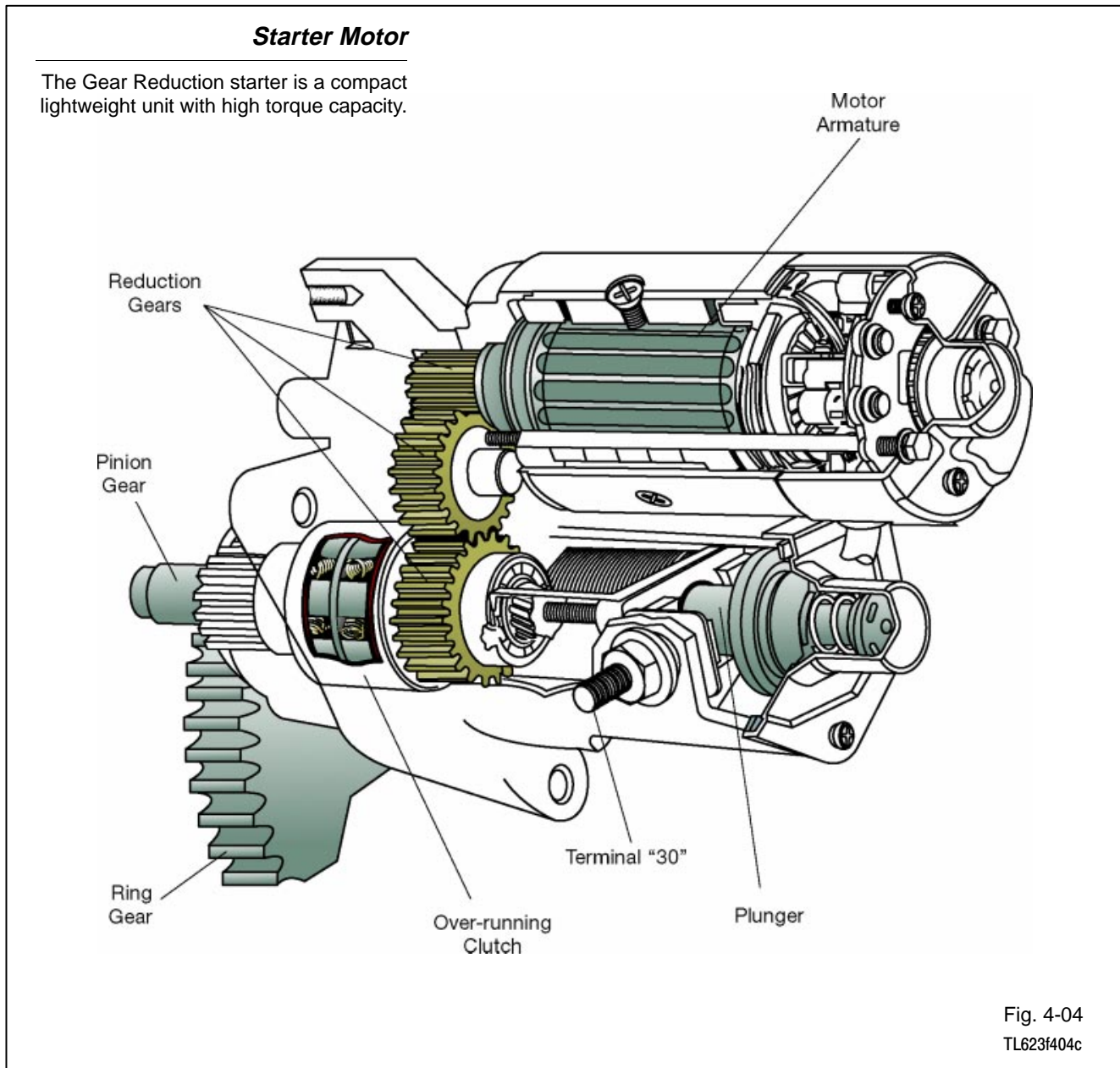

Fig. 4-03
L623f403

Starter Motor Toyota vehicles are fitted with one of two types of starter motors:

- Gear reduction
- Planetary Reduction Segment (PS)



Gear-Reduction Starter Motor The gear-reduction starter motor contains the components shown. This type of starter has a compact, high-speed motor and a set of reduction gears. While the motor is smaller and weighs less than conventional starting motors, it operates at higher speed. The reduction gears transfer this torque to the pinion gear at $\frac{1}{4}$ to $\frac{1}{3}$ the motor speed. The pinion gear still rotate faster than the gear on a conventional starter **and** with much greater torque (cranking power).

The reduction gear is mounted on the same shaft as the pinion gear. Unlike the conventional starter, the magnetic switch plunger acts directly on the pinion gear (not through a drive lever) to push the gear into mesh with the ring gear.

This type of starter was first used on the 1973 Corona MKII with the 4M, six cylinder engine. It is now used on most 1975 and newer Toyotas. Ratings range from 0.8 KW on most Tercels and some older models to as high as 2.5 KW on the diesel Corolla, Camry and Truck. The cold-weather package calls for a 1.4 KW or 1.6 KW starter, while a 1.0 KW starter is common on other models.

The gear-reduction starter is the replacement starter for most conventional starters.

NOTE Older Toyota models use conventional type starters. This type of starter drives the pinion gear directly. The pinion gear turns at the same speed as the motor shaft. These starters are heavier and draw more current than gear reduction and PS type starters.

Conventional Starter Motor

Conventional type starter motors drive the pinion directly.

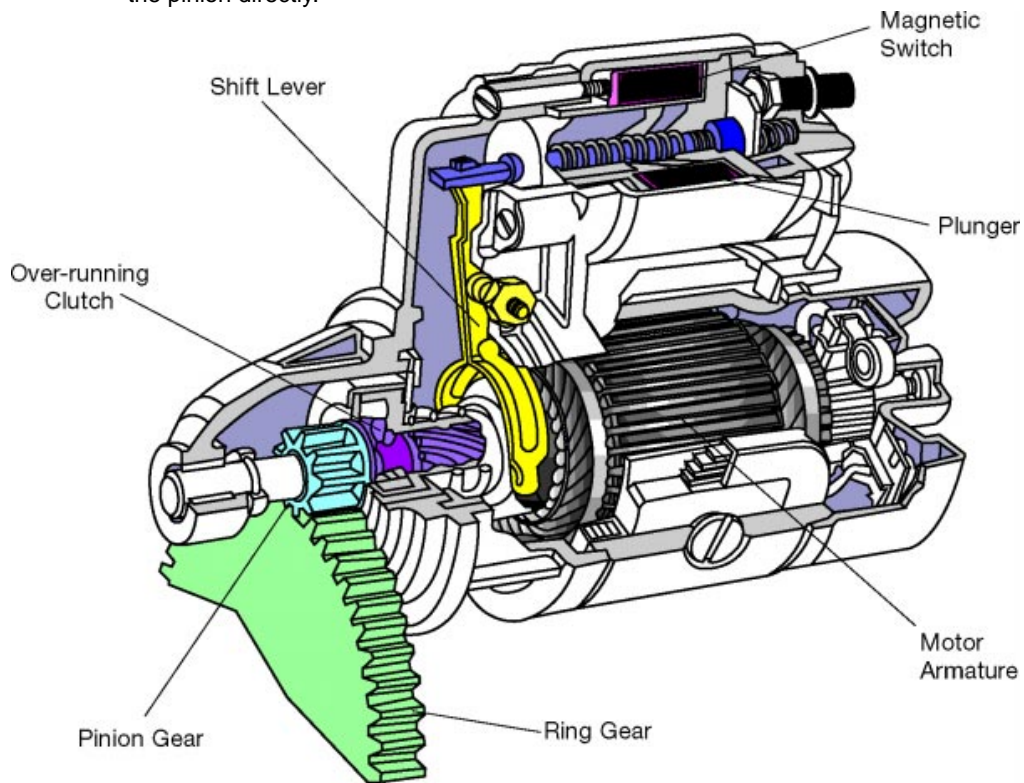
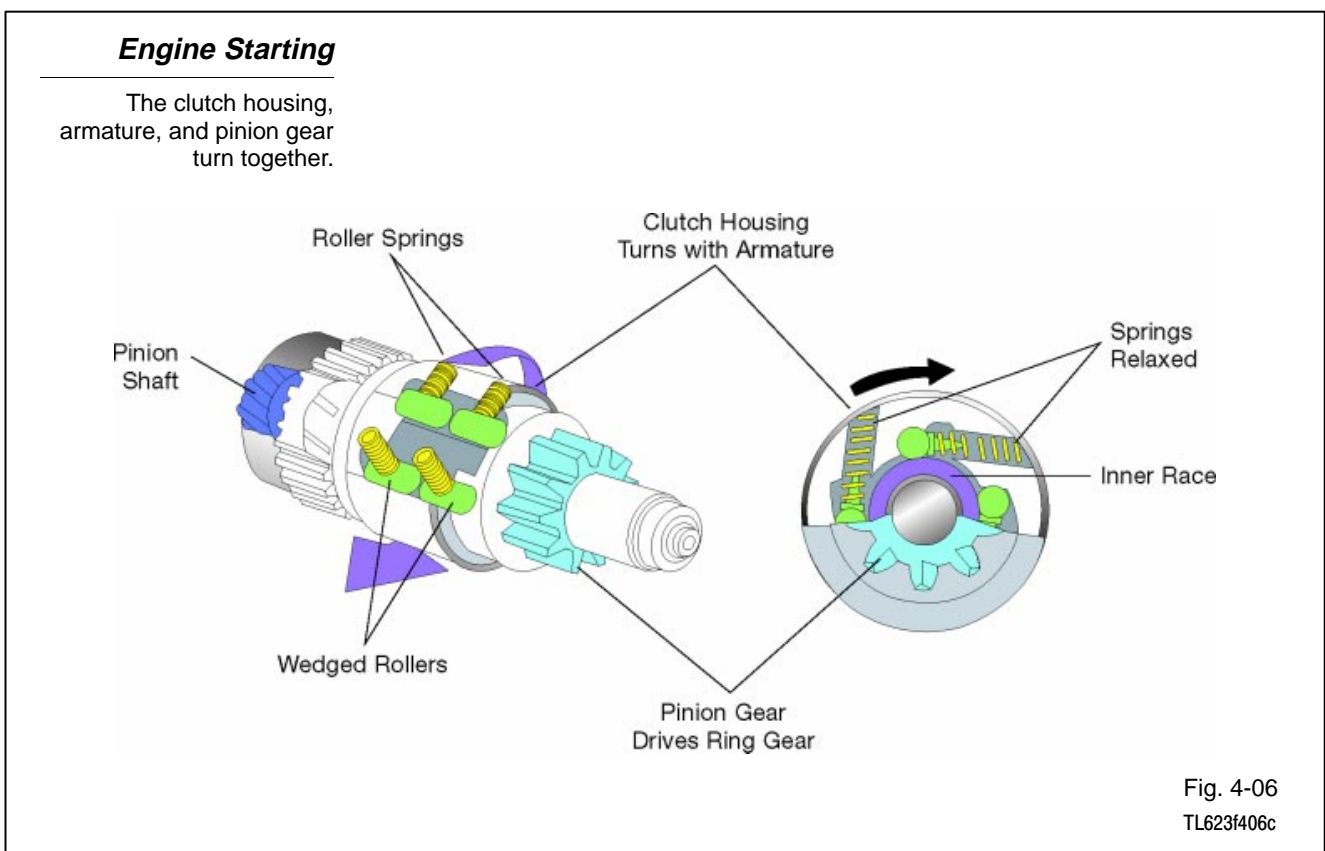

Fig. 4-05
TL623f405c

Over-running Clutch Both conventional and gear reduction starter motors are fitted with a one-way, over-running clutch. The clutch prevents damage to the starter when the engine starts.

Clutch Operation:

1. During engine start, the starter pinion gear drives the engine's flywheel ring gear.
2. Once the engine fires, the ring gear almost instantly begins to turn faster than the starter pinion gear. Over-speeding would damage the starter motor if it were not immediately disengaged from the pinion gear.
3. The clutch uses its wedged rollers and springs to disengage the pinion shaft from the clutch housing (which turns with the motor armature). This happens any time the pinion shaft tries to turn faster than the clutch housing.



Engine Started

The clutch housing and the armature turn together. The ring gear drives the pinion gear. The pinion shaft is disengaged from the clutch housing.

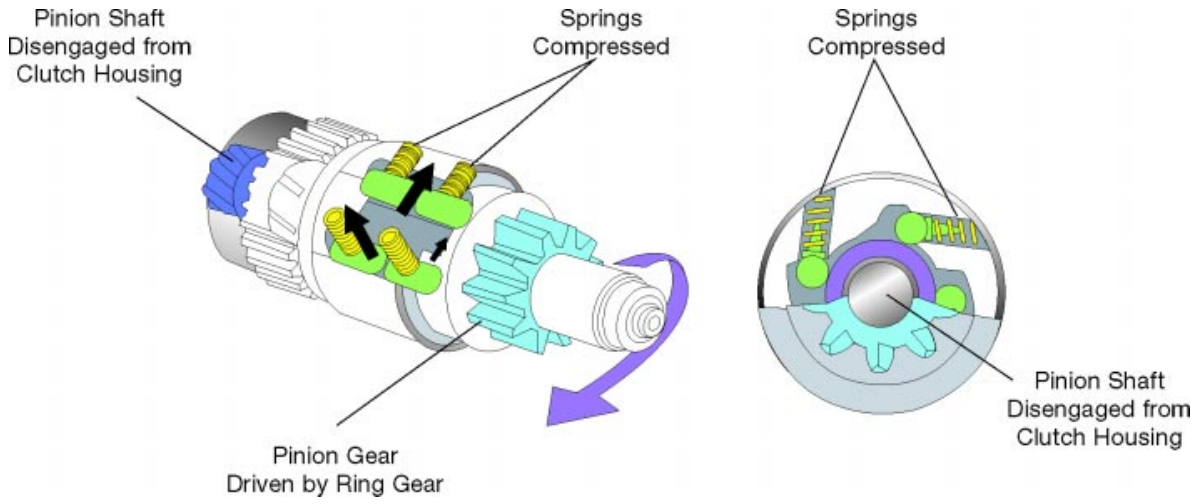
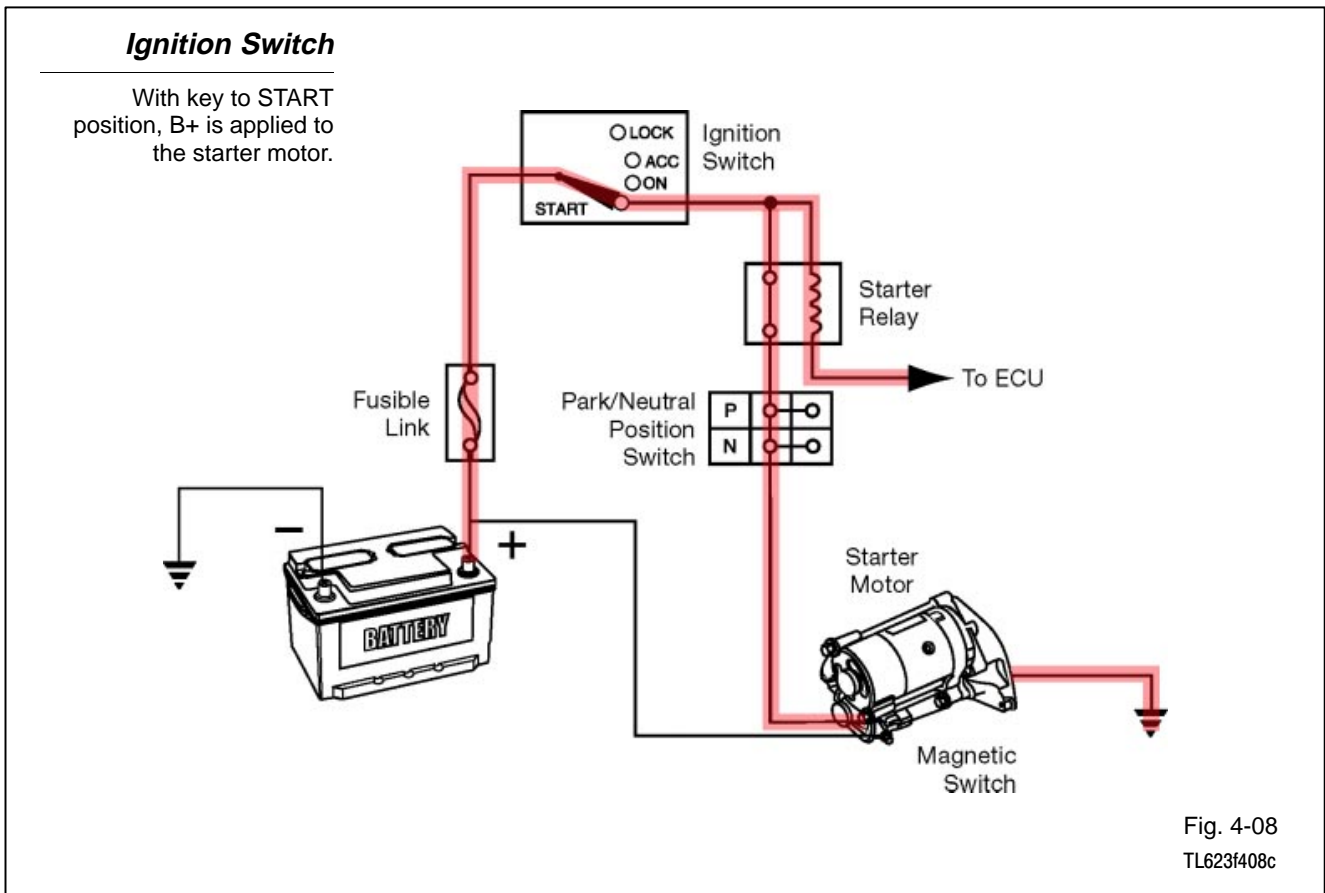

Fig. 4-07
TL623f407c

Ignition Switch The ignition switch incorporates contacts to provide B+ to the starter. The relay energizes the starter magnetic switch when the driver turns the ignition key to the START position.



**Park/Neutral
Position Switch
(Automatic
Transmission)**

The park/neutral position switch prevents operation of the starter motor unless the shift lever is in Park or Neutral. The switch contacts are in series with the starter control circuit.

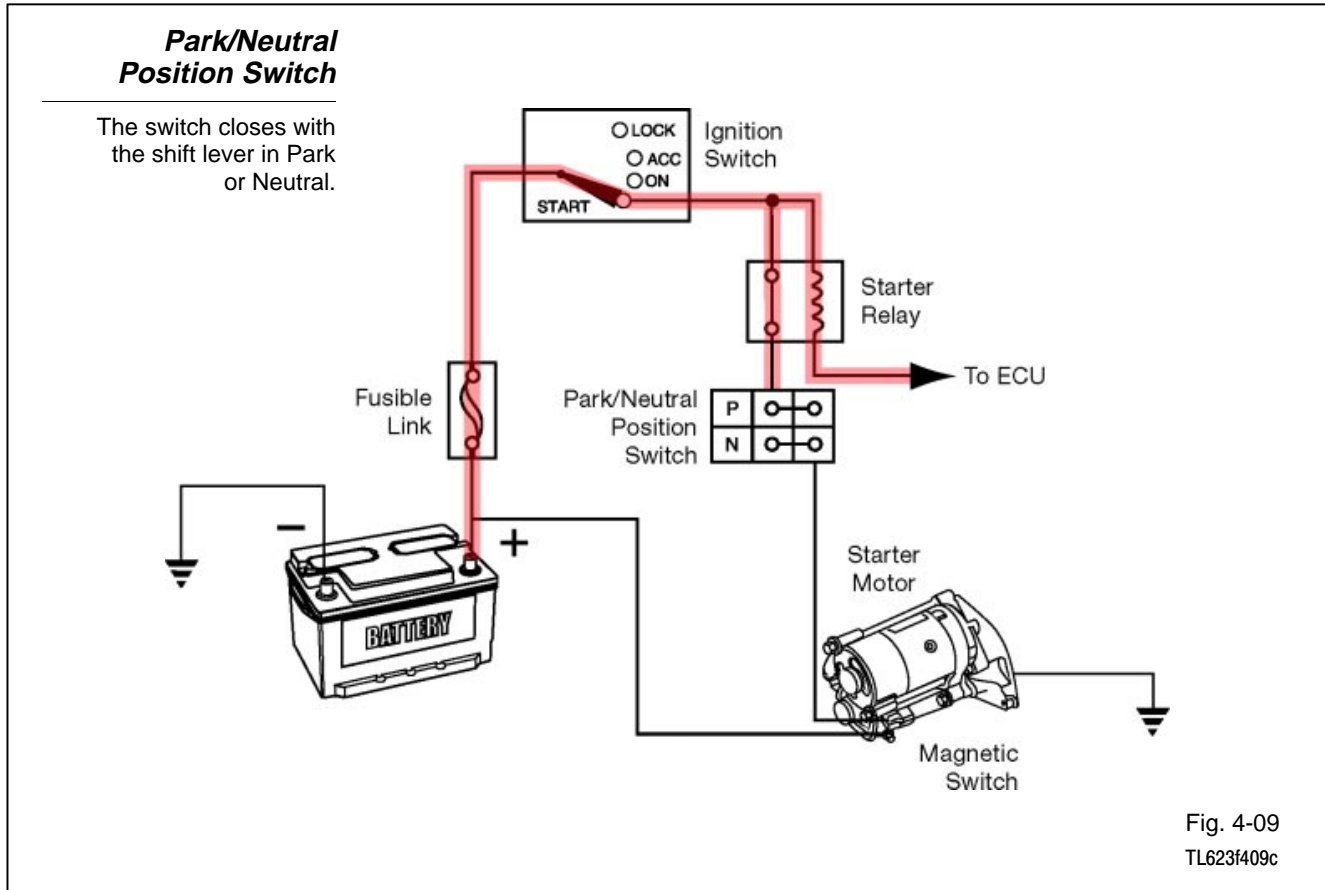

Clutch Start Switch (Manual Transmission) For manual transmissions the clutch start switch performs the same function as the park/neutral position switch. The clutch start switch opens the starter control circuit unless the clutch is engaged.

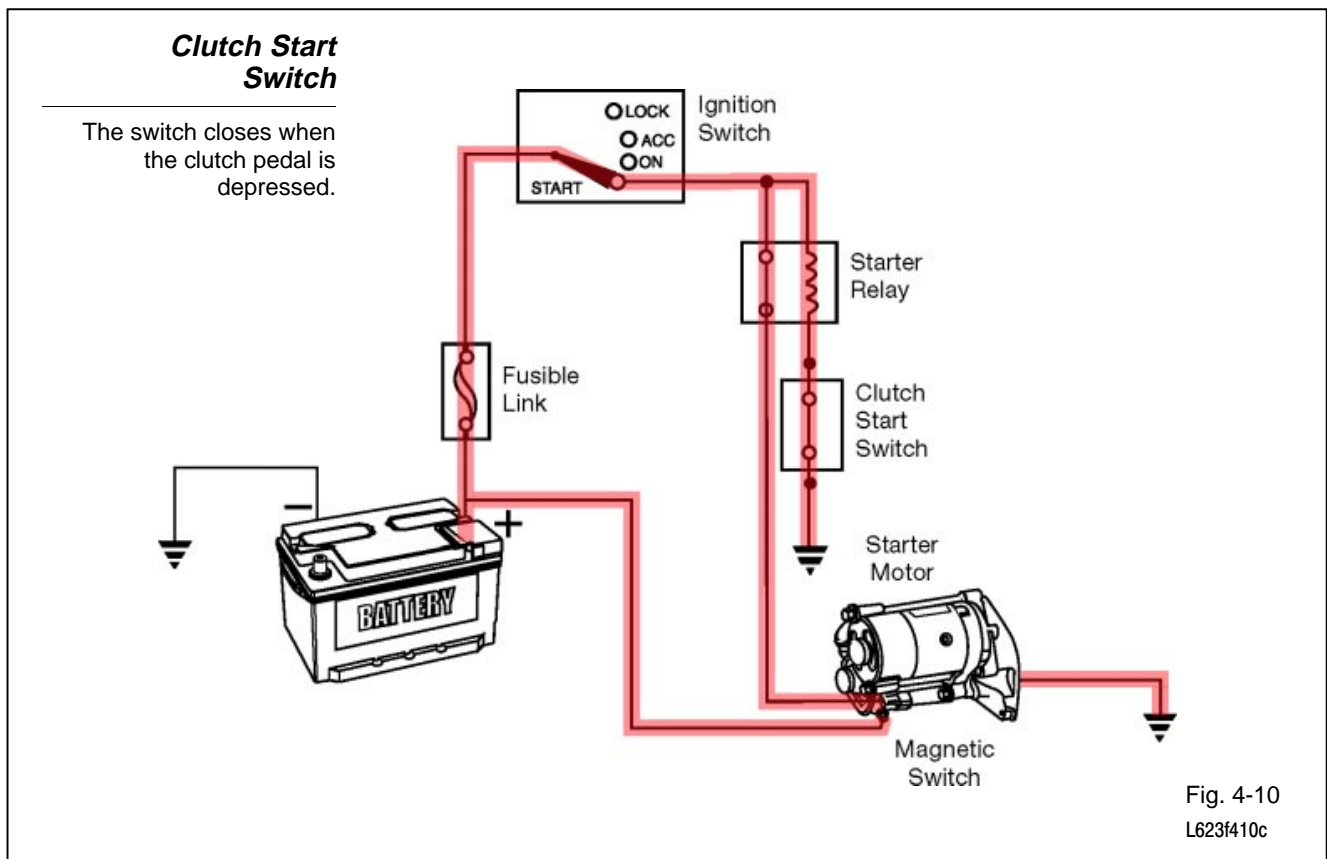

Clutch Start Cancel Switch

In some off-road situations it is advantageous to start a manual transmission vehicle while in gear with the clutch engaged. The driver-controlled safety cancel switch allows the driver to bypass the clutch start switch to make this possible. This feature is only available on some models.

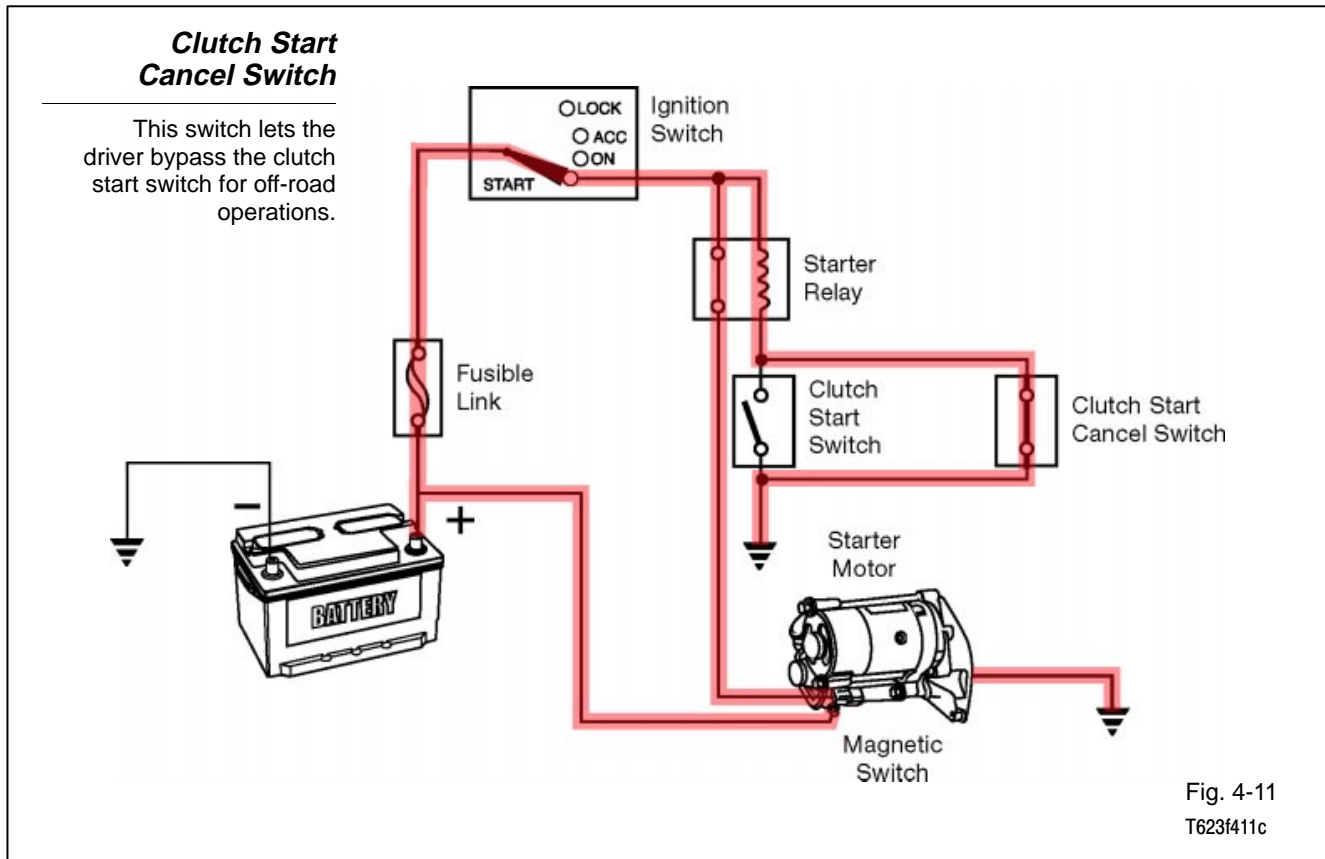

Gear-Reduction Starter Operation

Ignition switch in ST:

1. Current travels from the battery through terminal "50" to the hold-in and pull-in coils. Then, from the pull-in coil, current continues through terminal "C" to the field coils and armature coils.
2. Voltage drop across the pull-in coil limits the current to the motor, keeping its speed low.
3. The magnetic switch plunger pushes the pinion gear to mesh with the ring gear.
4. The screw spline and low motor speed help the gears mesh smoothly.

Ignition Switch to ST

The plunger pulls the drive lever, which moves the pinion gear into engagement with the ring gear.

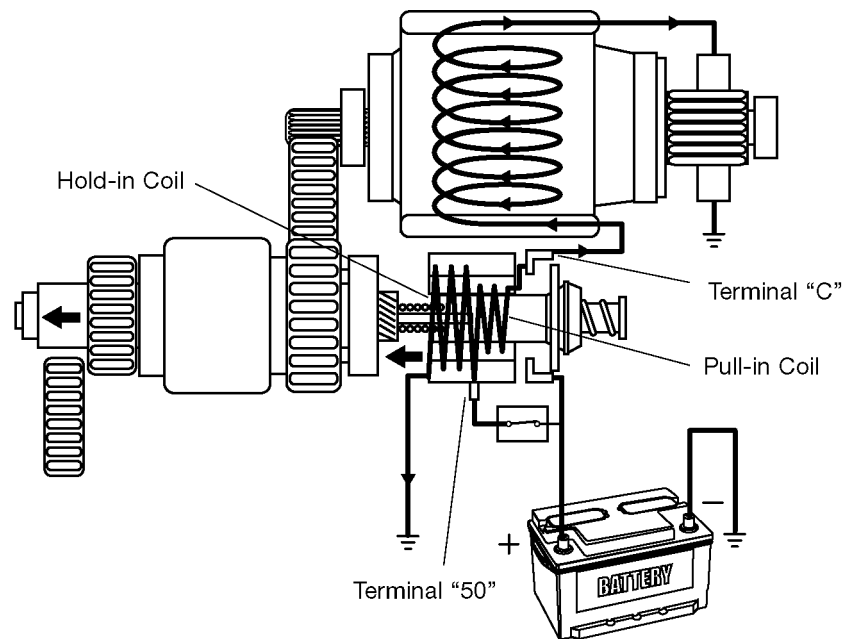

Current Flow

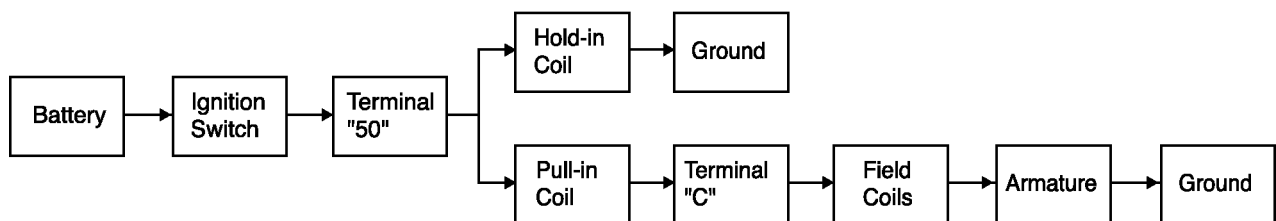

Fig. 4-12
TL623f412

Pinion and ring gears engaged:

1. When the gears are meshed, the contact plate on the plunger turns on the main switch by closing the connection between terminals "30" and "C."
2. More current goes to the motor and it rotates with greater torque.
3. Current no longer flows in the pull-in coil. The plunger is held in position by the hold-in coil's magnetic force.

Ignition Switch to ST (Cont.)

The magnetic switch closes and current from the battery drives the starter motor directly.

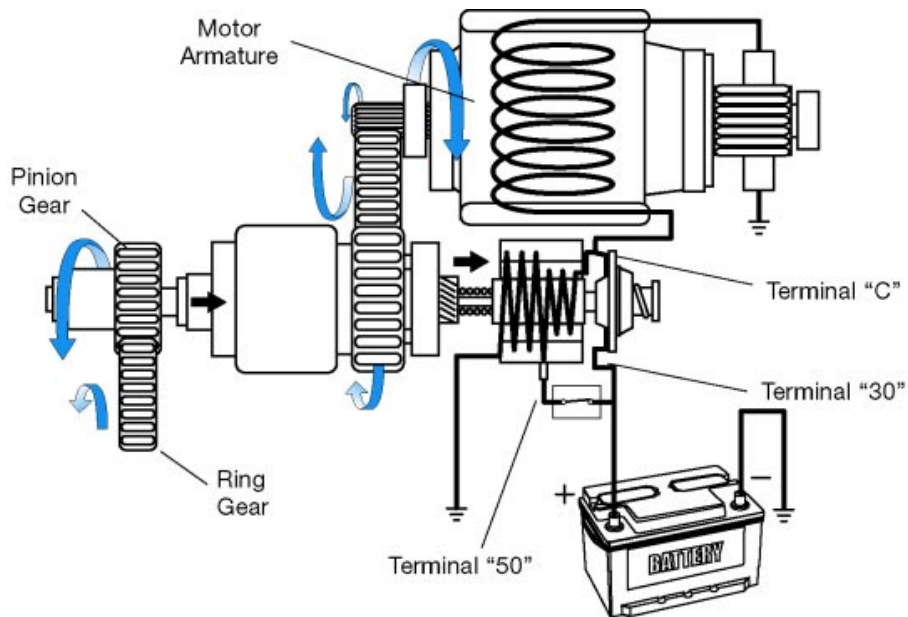

Current Flow

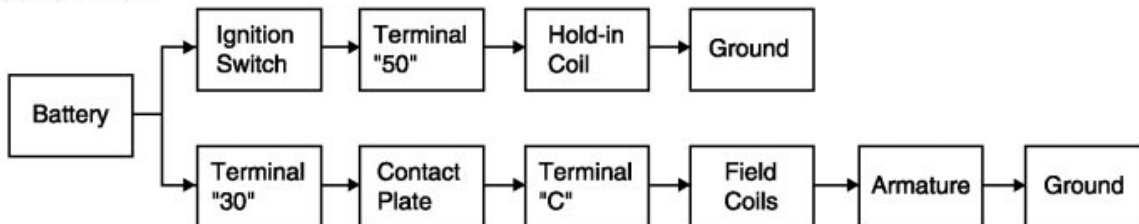

Fig. 4-13
TL623f413c

Ignition switch in ON:

1. Current no longer present at terminal "50," but the main switch remains closed to allow current from terminal "C" through the pull-in coil to the hold-in coil.
2. The magnetic fields in the two coils cancel each other, and the plunger is pulled back by the return spring.
3. The high current to the motor is cut off and the pinion gear disengages from the ring gear.
4. The armature has less inertia than the one in a conventional starter. Friction stops it, so a brake is not needed.

Ignition Switch ON

Current through the starter relay stops. The pinion gear disengages from the ring gear, and the magnetic switch opens.

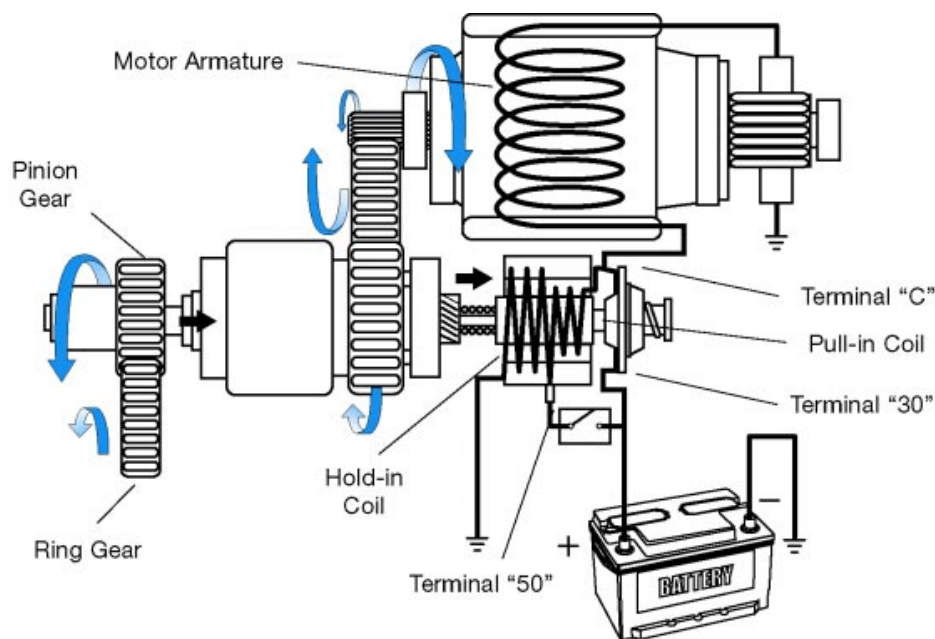

Current Flow

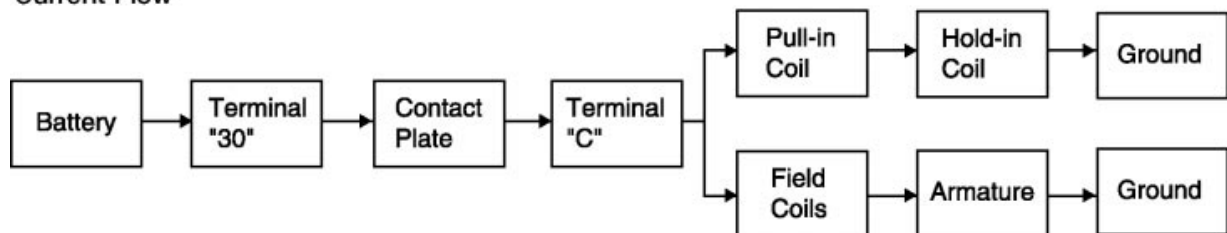

Fig. 4-14
TL623f414c

PS Starter Motors - Overview All current Toyota models are fitted with Planetary Reduction Segment Conductor (PS) starters.

Planetary reduction allows the starter motor to operate at a higher speed than a conventional starter.

- The reduction gear set reduces the pinion gear speed compared to motor shaft speed.
- Higher motor speed yields greater torque.

Segment conductor type starters incorporate several design improvements:

- More compact
- Lighter weight
- Greater output torque

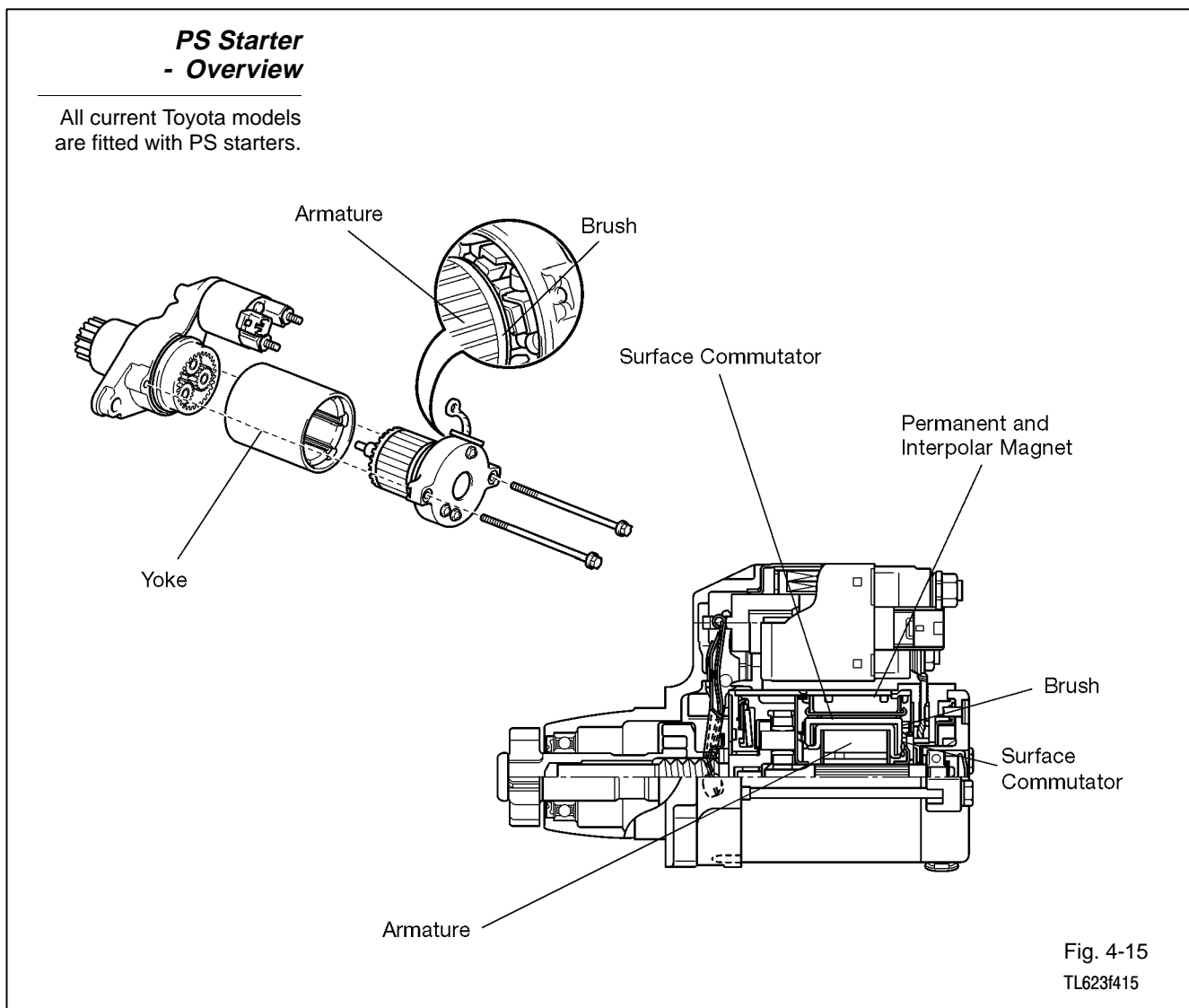

Fig. 4-15
TL623f415

**PS Starter
- Construction**

Coil wires in PS type starters are square in cross-section for more compact winding and greater output torque.

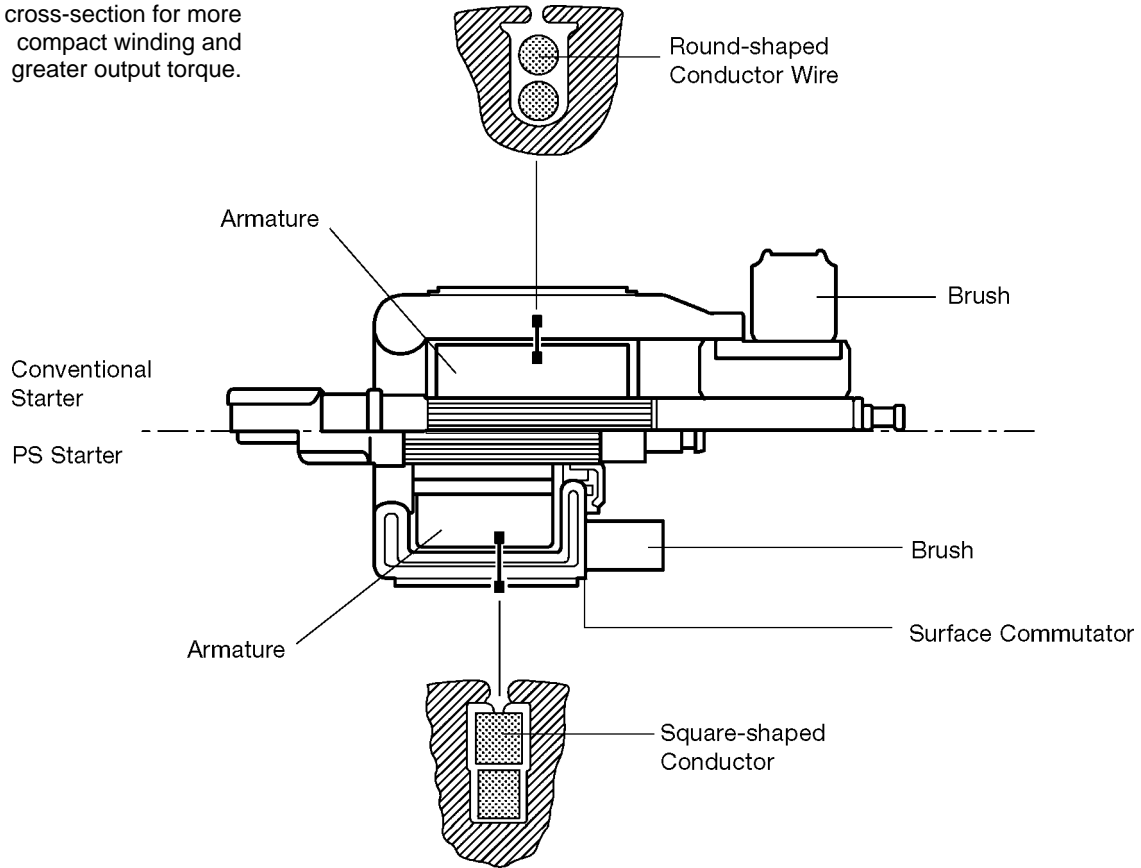

Fig. 4-16
TL623f416

PS Starter Motors - Construction

Armature coil wires - The coil wires in a PS starter armature are square in cross-section.

- More compact winding than round cross-section wires
- Greater output torque

Surface commutator - The square shape of the armature conductors allow the surface of the armature to act as a commutator.

Field coils - Conventional starters use field coils. PS type starters use two types of permanent magnets instead:

- Main magnets
- Inter-polar magnets

The two types of magnets are arranged alternately inside the yoke.

- Work together to increase magnetic flux
- Allows shorter yoke

PS Starter - Construction

PS type starters use two types of permanent magnets instead of field coils.

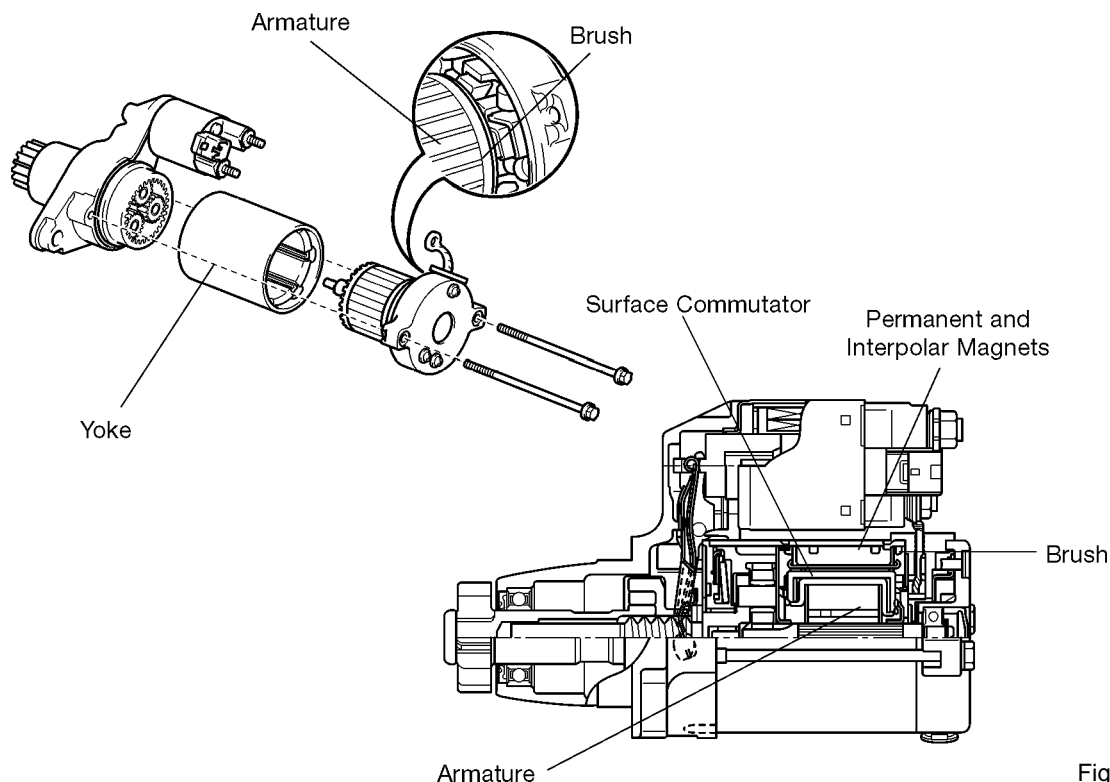

Fig. 4-17
TL623f415

PS Starter Operation

With the ignition switch placed to the START position:

1. Current travels from the battery through the closed ST1 contacts of the Ignition Switch and the Park/Neutral Switch, through the coil of the ST Relay to ground.
2. The ST Relay contacts close.

Ignition Switch to START

Current from Ignition Switch ST1 contacts energizes the ST Relay coil.

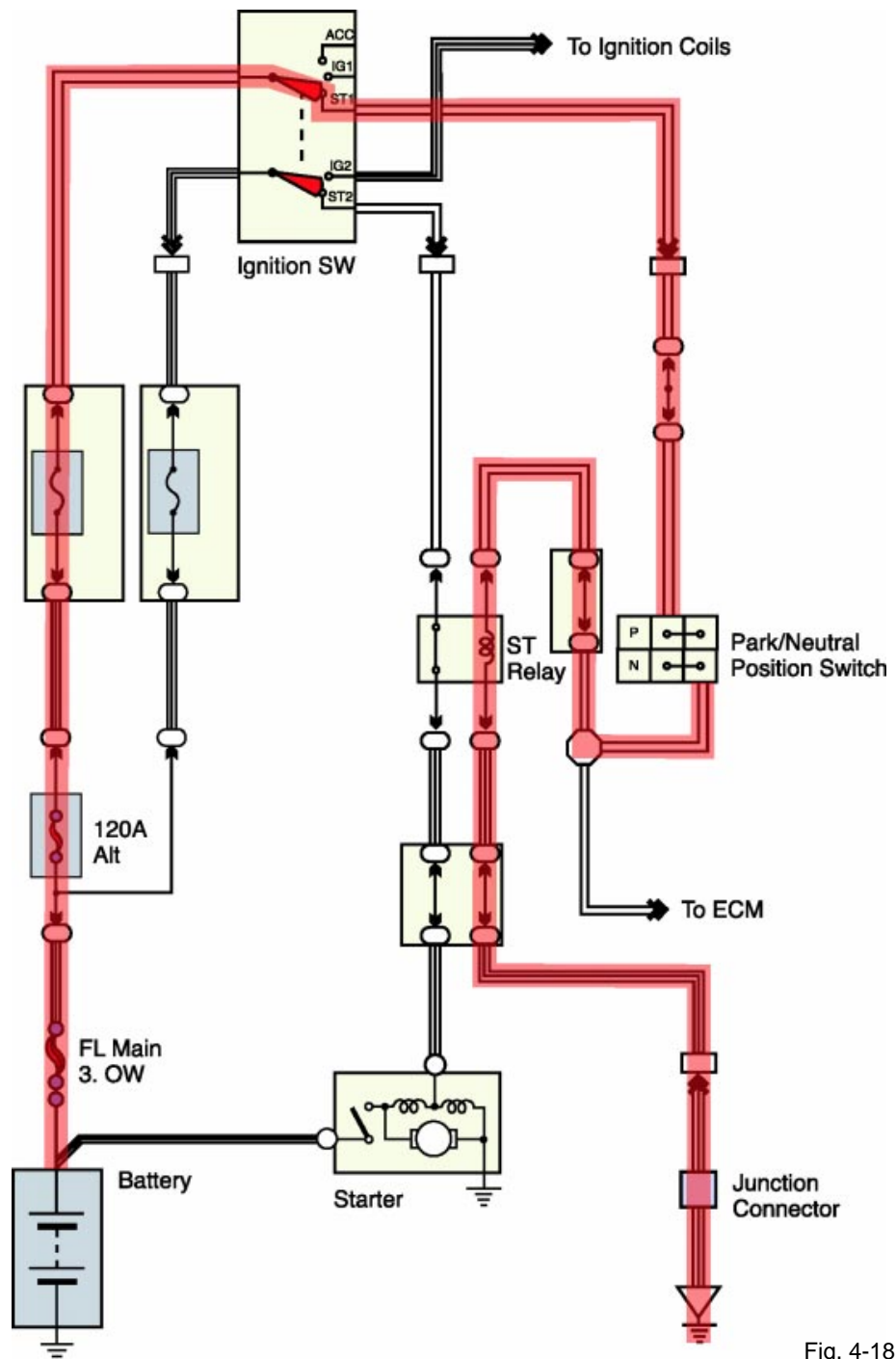
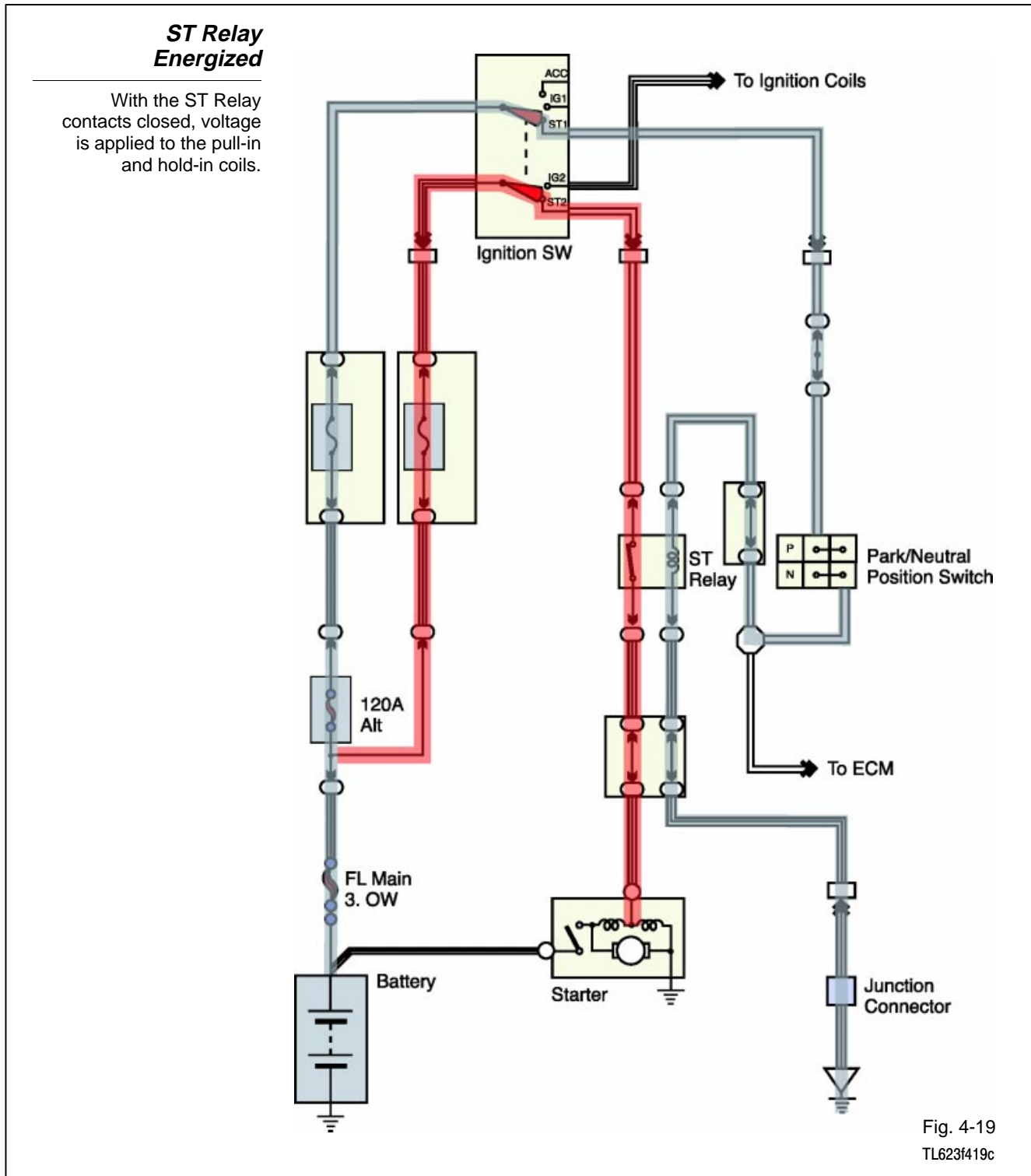

Fig. 4-18
TL623f418c

3. Voltage is applied through the closed ST2 contacts of the Ignition Switch to the hold-in and pull-in coils of the starter.



- Current is present through the hold-in coil to ground and through the pull-in coil and the starter motor windings (armature and field coil) to ground. The voltage drop created by the pull-in coil limits current through the motor windings and keeps motor speed low.

Starter Motor Turns at Slow Speed

Current is present through the hold-in coil to ground and through the pull-in coil and the motor windings to ground.

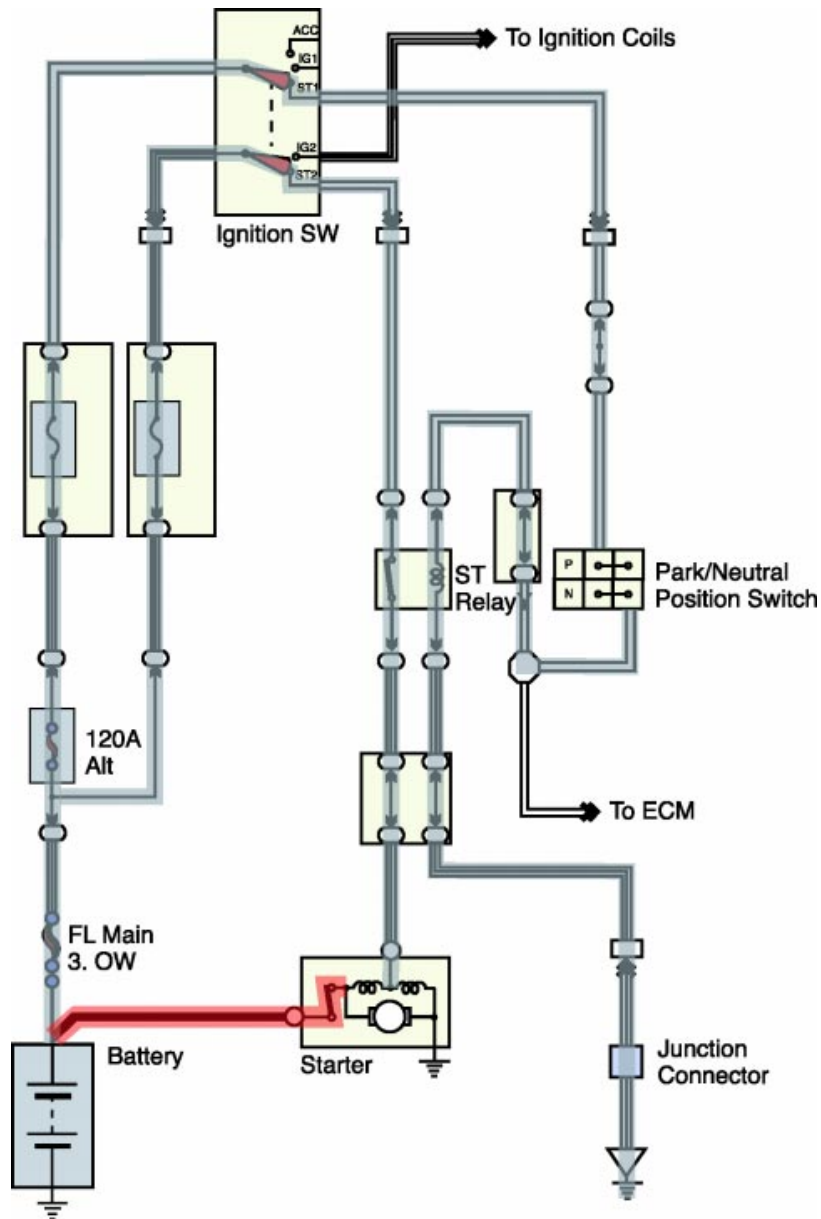

Fig. 4-20
TL623f420c

5. With the pull-in coil energized, the solenoid plunger moves the drive lever to mesh the pinion gear with the ring gear.
6. As the pinion gear engages the ring gear, the magnetic switch closes.
7. With the magnetic switch closed, voltage is applied directly from the battery, through the magnetic switch, to the pull-in coil. With voltage applied to both sides of the pull-in coil, no current is present through the coil. The magnetic switch is now held closed by the magnetic force of the still energized hold-in coil.

Current Through Pull-in Coil Stops

With battery voltage applied to both sides of the pull-in coil, no current is present in the coil.

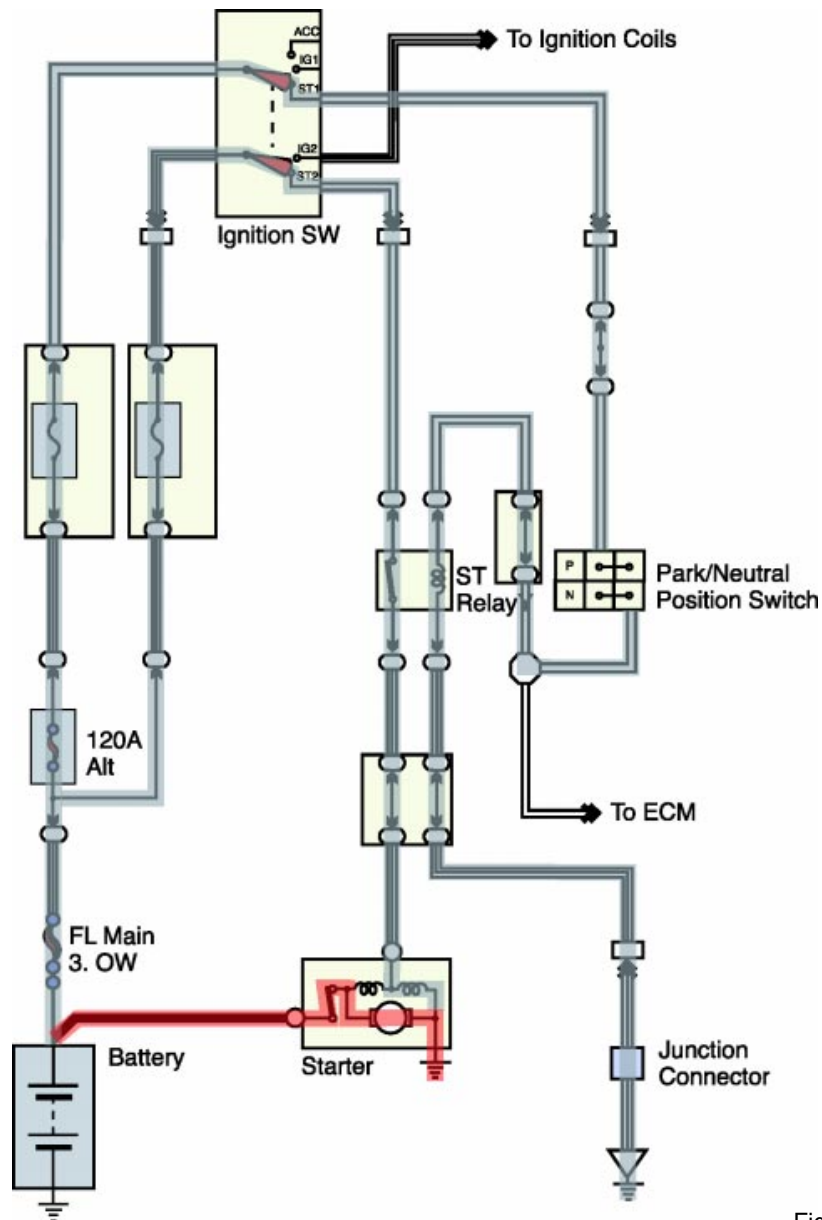

Fig. 4-21
TL623f421c

8. Current is now present from the battery through the closed magnetic switch and the motor windings to ground. This current is not limited through the pull-in coil, so it drives the starter motor with greater speed and torque.

Pinion Gear Engaged with Ring Gear

With the magnetic switch closed, there is a large current directly from the battery through the motor windings.

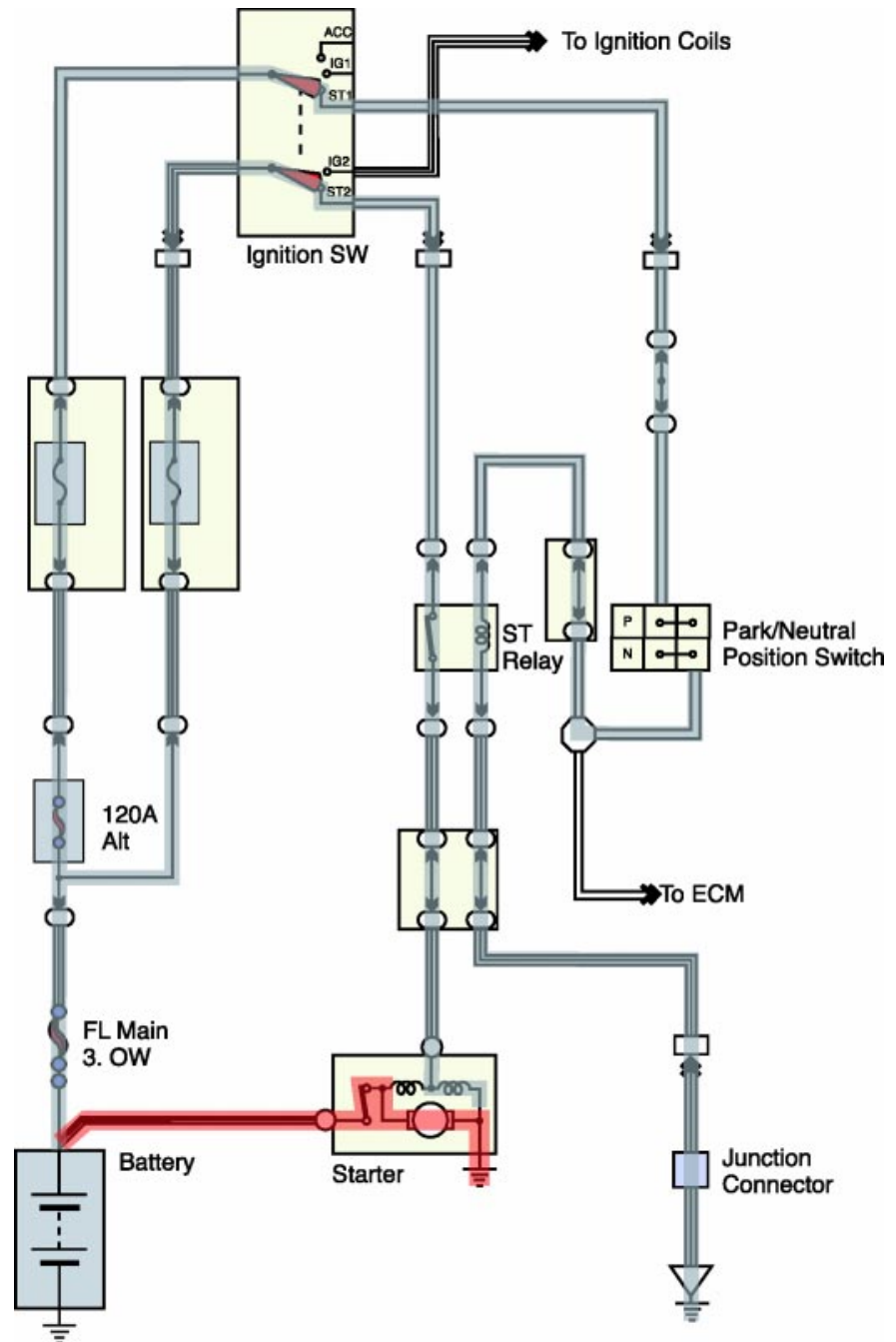
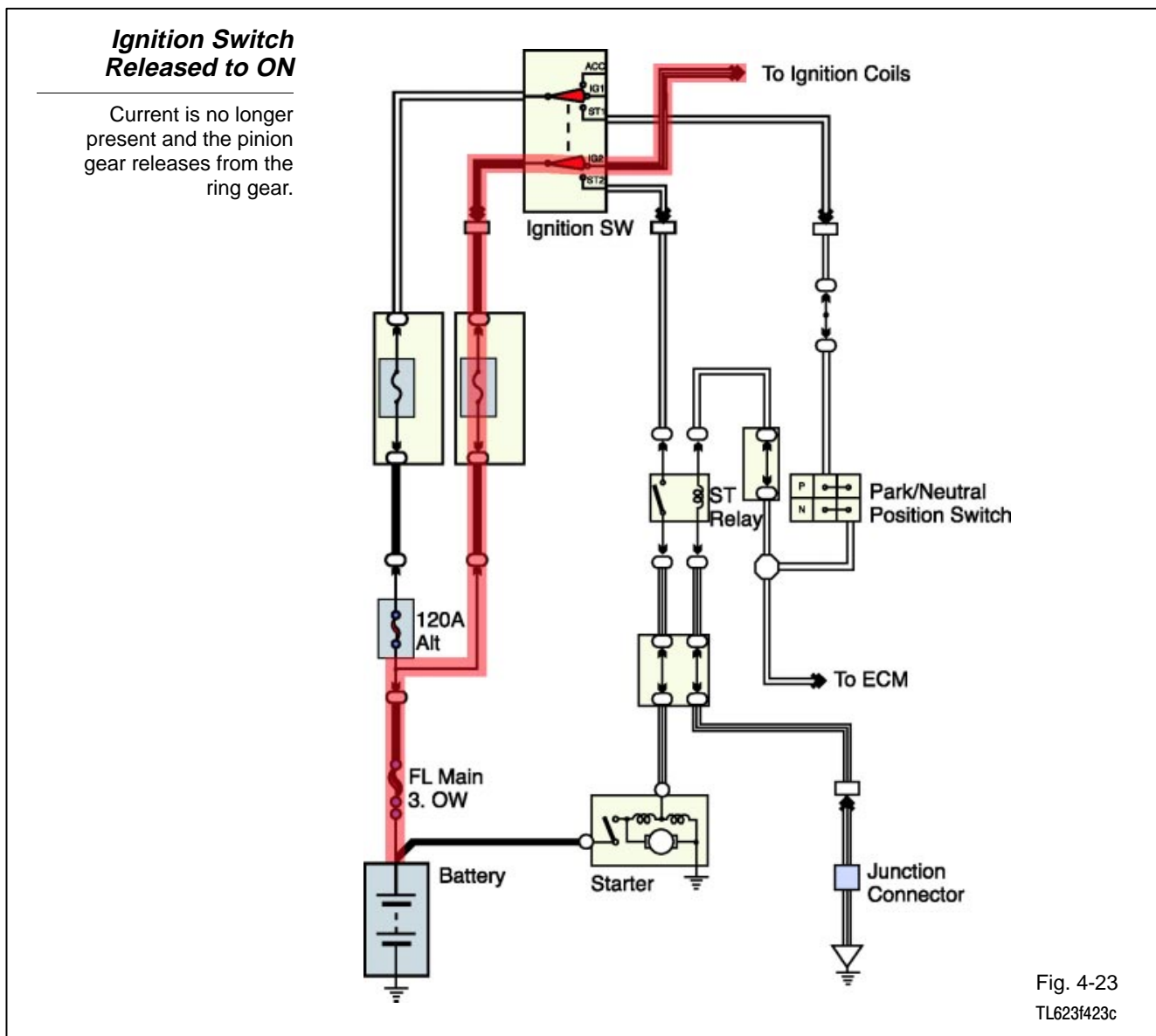

Fig. 4-22
TL623f422c

With the engine started and the ignition switch released to the ON or IG position:

9. Voltage is removed from the Ignition Switch ST contacts and applied to the IG contacts. Current is present through the IG2 contacts to the ignition coils.
10. Current through the hold-in coil stops. Current through the pull-in coil reverses direction and flows from the battery through the magnetic switch, the pull-in coil, and the hold-in coil to ground. With current through the pull-in coil reversed, the magnetic fields of the pull-in and hold-in coils cancel each other out.
11. A return spring pulls the solenoid plunger and the drive lever back. The pinion gear disengages from the ring gear. The magnetic switch opens. Current through the starter motor stops.



Diagnosis and Testing The starting system requires little maintenance. The battery should be fully charged and connections kept clean and tight.

Diagnosis of starting system problems is usually straightforward. Problems may be electrical or mechanical.

The Starting System Troubleshooting chart lists the most common starting system problems, the possible causes, and recommended actions to resolve the problem.

Begin with a thorough visual inspection. If this fails to turn up the possible cause, several tests are available to help you find the problem:

- Starter motor current draw test
- Voltage drop tests
- Operational and continuity tests
- Starter motor bench tests

Starting System Troubleshooting Chart

Symptoms	Possible Cause	Action Needed
Engine will not crank	<ul style="list-style-type: none"> • Dead battery • Melted fusible link • Loose connections • Faulty ignition switch • Faulty magnetic switch, relay, neutral start switch or clutch switch • Mechanical problem in engine • Problem in theft deterrent system 	<ul style="list-style-type: none"> • Check battery state-of-charge • Replace fusible link • Clean and tighten connections • Check switch operation; replace as needed • Check and replace as needed • Check engine • Check repair manual for system tests
Engine cranks too slowly to start	<ul style="list-style-type: none"> • Weak battery • Loose or corroded connections • Faulty starter motor • Mechanical problems with engine or starter 	<ul style="list-style-type: none"> • Check battery and charge as needed • Clean and tighten connections • Test starter • Check engine and starter; replace worn out parts
Starter keeps running	<ul style="list-style-type: none"> • Damaged pinion or ring gear • Faulty plunger in magnetic switch • Faulty ignition switch or control circuit • Binding ignition key 	<ul style="list-style-type: none"> • Check gears for wear or damage • Test starter pull-in and hold-in coils • Check switch and circuit components • Check key for damage
Starter spins, but engine will not crank	<ul style="list-style-type: none"> • Faulty over-running clutch • Damaged or worn pinion gear or ring gear 	<ul style="list-style-type: none"> • Check over-running clutch for proper operation • Check gears for damage and wear; replace as needed
Starter does not engage/disengage properly	<ul style="list-style-type: none"> • Faulty magnetic switch • Damaged or worn pinion gear or ring gear 	<ul style="list-style-type: none"> • Check and replace as needed • Check gears for damage and wear; replace as needed

Fig. 4-24

Visual Inspection A visual inspection of the starting system can save you time and effort by uncovering obvious or simple and easy-to-fix problems.

CAUTION

The battery contains sulfuric acid. Take precautions to avoid possible injury or damage to the vehicle:

- Remove rings, wristwatch, and any other jewelry that might contact the battery terminals before beginning the inspection.
- Wear safety glasses and protective clothing to protect yourself from acid.

Include these components in your inspection:

- Battery
- Starter
- Ignition switch
- Park/neutral position or clutch start switch

Visual Inspection

BATTERY

- Inspect the battery for external damage to the case or the cables, corroded terminals, and loose connections.
- Check the battery's state of charge (with a battery analyzer). Charge if needed.
- Check the electrolyte level and top up with distilled water if needed.

STARTER

- Inspect the starter motor for external damage to the case or wiring (including the magnetic switch circuit), corroded terminals, and loose connections.
- Check for loose mounting hardware. Tighten as needed.

IGNITION SWITCH

- Inspect the ignition switch for loose connections and damaged wiring.
- Confirm that the battery voltage is available at the magnetic switch with the ignition switch set to ON and the clutch switch or neutral start switch closed.
- If you suspect the ignition switch is faulty, use a remote starter switch and jumper wire to confirm starter operation.

PARK/NEUTRAL/CLUTCH START SWITCHES

- Conduct a voltage drop test to verify proper operation (max. 0.1 V drop).

Fig. 4-25

Current Draw Test The starter current draw test effectively checks the entire starting system. A special purpose tester connects to the battery to measure starting current and cranking voltage.

The procedure shown here applies to the VAT-40 and (with some minor differences) the VAT-60:

1. Make a visual inspection of the battery, electrolyte, and battery cables.
2. Turn off all electrical accessories and lights in the vehicle; set ignition switch to OFF.
3. Disable the fuel or ignition system so the engine will not start while cranking.
4. Connect the tester in this sequence:
 - Red lead to positive battery terminal
 - Black lead to negative battery terminal
 - Current probe on negative battery cable

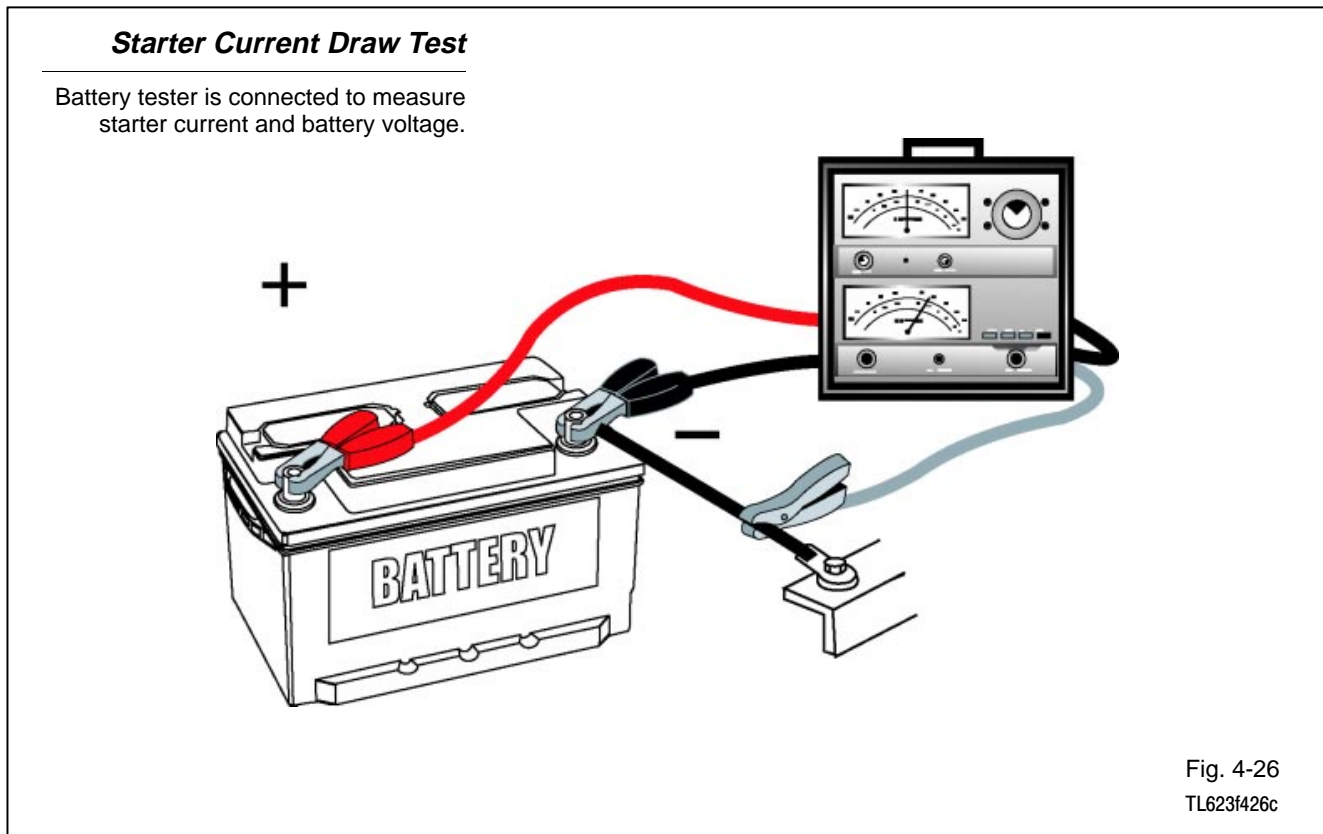

5. For VAT-40, set the voltage selector to EXT 18 (volts).
6. Without cranking the engine, note the voltage reading.
 - Should be at least 12.6 volts.
 - Recharge the battery before proceeding if the voltage is below 12.6 volts.
7. Crank the engine and observe the voltage and current readings.
 - Engine speed should be between 200 and 250 RPM while cranking.
 - Voltage should be at or above the service specification (refer to appropriate repair manual).
 - Current should be at or below the service specification (refer to appropriate repair manual).
8. When finished with the test, disconnect the tester leads and enable the fuel or ignition system (replace fuse or relay).

NOTE

For most Toyota vehicles, you can pull the Electronic Fuel Injection (EFI) fuse or relay to prevent engine start.

You can connect the current probe to either battery cable. Just be sure to orient the arrow on the probe correctly. The arrow should point down (away from the battery) for the positive cable; the arrow should point up (toward the battery) for the negative cable.

Do not crank the engine longer than 10 seconds at a time.

Voltage Drop Tests
- Starter Motor
Circuit

Voltage drop tests can find excessive resistance in the starting system. High resistance in the starter motor circuit can ...

- Reduce starter motor current.
- Cause slow cranking.

Preparation - Prepare the tester and the vehicle with these steps:

1. Disable the fuel or ignition system so engine will not start while cranking.

NOTE

For most Toyota vehicles, you can pull the Electronic Fuel Injection (EFI) fuse or relay to prevent engine start.

2. Set the VAT-40 volt selector to EXT 3 (volts). If you're using a DMM, select a low voltage scale.
3. Connect the VAT-40 or DMM leads to measure voltage drop for the following:
 - Battery + post to + cable
 - Battery + cable to starter
 - Starter relay to starter (PS type)
 - Starter case to - cable • - cable to - battery post
 - Terminal C to terminal 30 (gear reduction type)
 - Battery to terminal 50 (gear reduction type)

Normal voltage drops in the starting system are in the range of 0.2 volts to 0.5 volts.

Battery Positive Cable

This test measures the voltage drop across the positive battery post to the cable and the connections at the battery and the starter.

NOTE

Do not crank the engine longer than 10 seconds at a time.

Crank the engine and note the voltage reading:

- 0.5 volts or less is acceptable resistance
- More than 0.5 volts is excessive resistance

If you find excessive resistance, perform these steps:

- Isolate the cause
- Repair the fault
- Re-test the voltage drop

Excessive resistance could be caused by any of these:

- Damaged battery cable
- Poor connection at battery or starter terminal
- Defective magnetic switch

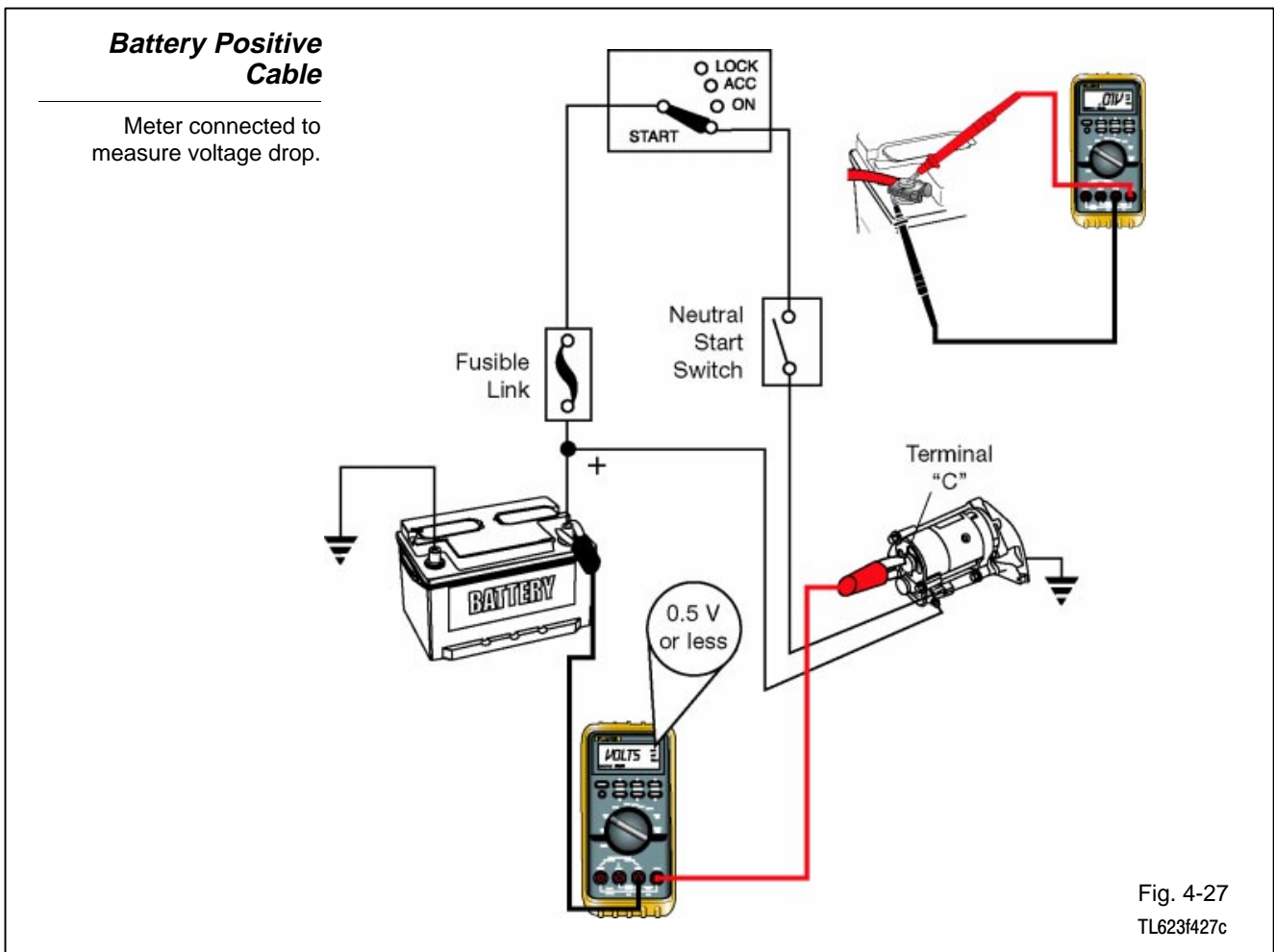

Battery Negative Cable This test measures the voltage drop across the negative battery cable, the connections at the battery and the starter, and the connection to ground through the starter motor case:

1. Connect the tester or meter leads:
 - Red lead to the starter motor housing
 - Black lead to negative terminal of the battery

NOTE Do not crank the engine longer than 10 seconds at a time.

2. Crank the engine and note the voltage reading:
 - 0.2 volts or less is acceptable resistance
 - More than 0.2 volts is excessive resistance

If you find excessive resistance, perform these steps:

- Isolate the cause
- Repair the fault
- Re-test the voltage drop

Excessive resistance could be caused by any of these:

- Damaged battery cable
- Poor connection at battery or starter terminal
- Poor connection between the starter case and the vehicle chassis (could be caused by a loose motor mount)

**Battery
Negative Cable**

Meter connected to measure voltage drop.

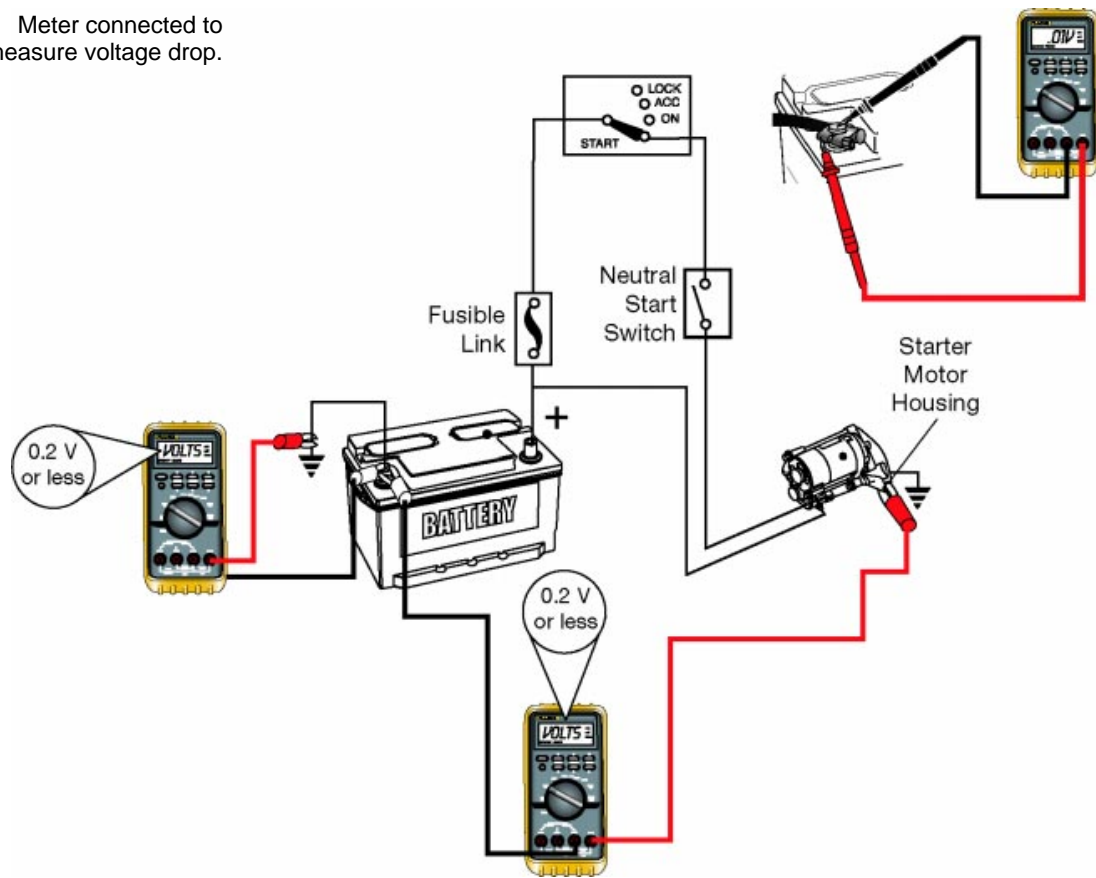

Fig. 4-28
TL623f428c

Magnetic Switch This test measures the voltage drop across the magnetic switch:

NOTE Starters with planetary gear reduction do not have a magnetic switch.

1. Connect the tester or meter leads:

- Red lead to starter terminal C
- Black lead to starter terminal 30

NOTE Do not crank the engine longer than 10 seconds at a time.

2. Crank the engine and note the voltage reading:

- 0.3 volts or less is acceptable resistance
- More than 0.3 volts is excessive resistance

If you find excessive resistance, perform these steps:

- Isolate the cause
- Repair the fault
- Re-test the voltage drop

A faulty magnetic switch could cause excessive resistance.

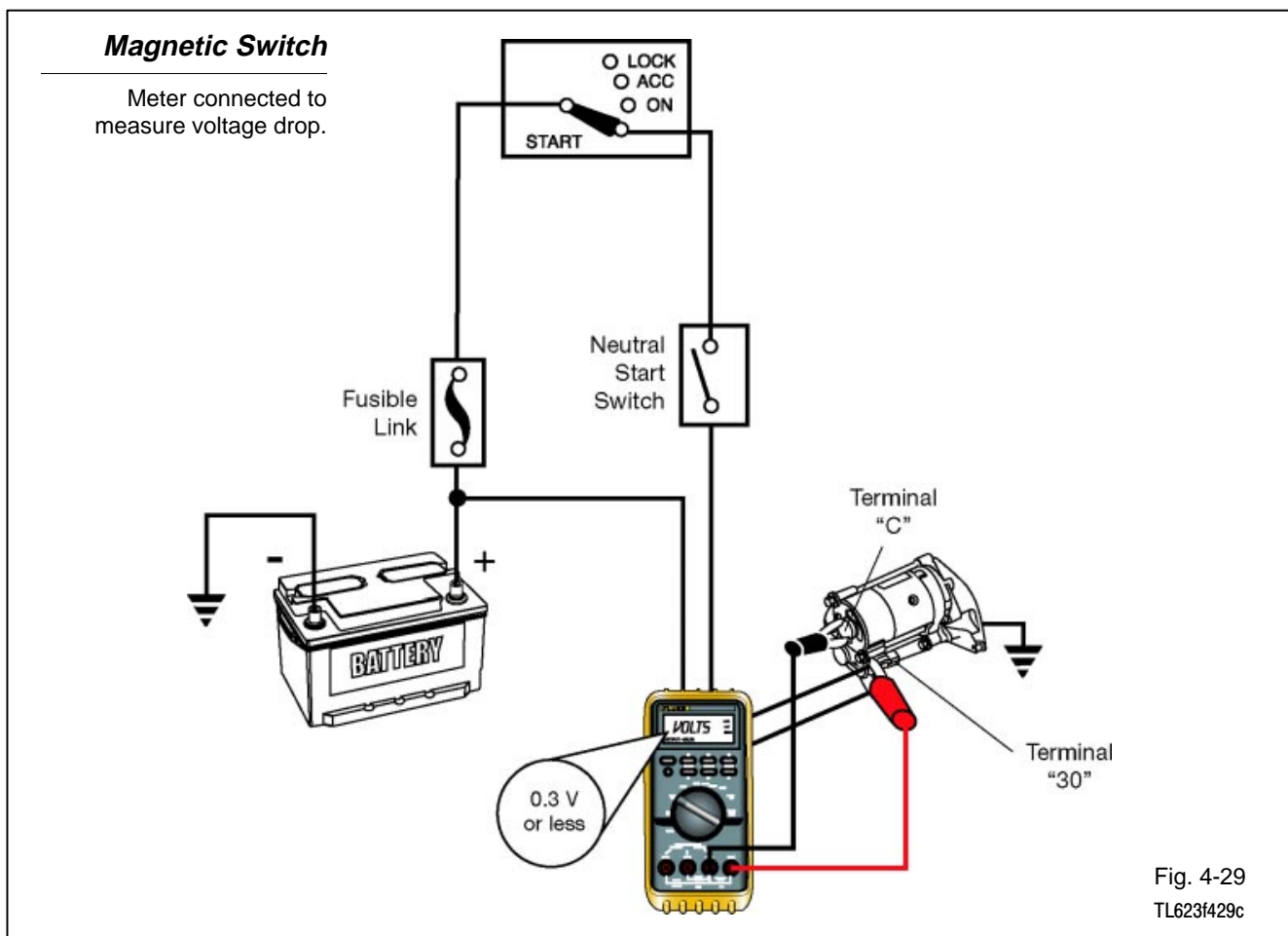

Voltage Drop Tests - Starter Control Circuit

Excessive resistance in the starter control circuit can reduce the voltage available to the magnetic switch. Symptoms of excessive voltage include the following:

- Pinion gear does not engage
- Pinion gear engages only partially

There are several areas where excessive resistance can occur:

- ST contacts of the ignition switch
- Neutral start switch /clutch start switch
- Circuit wiring and connections

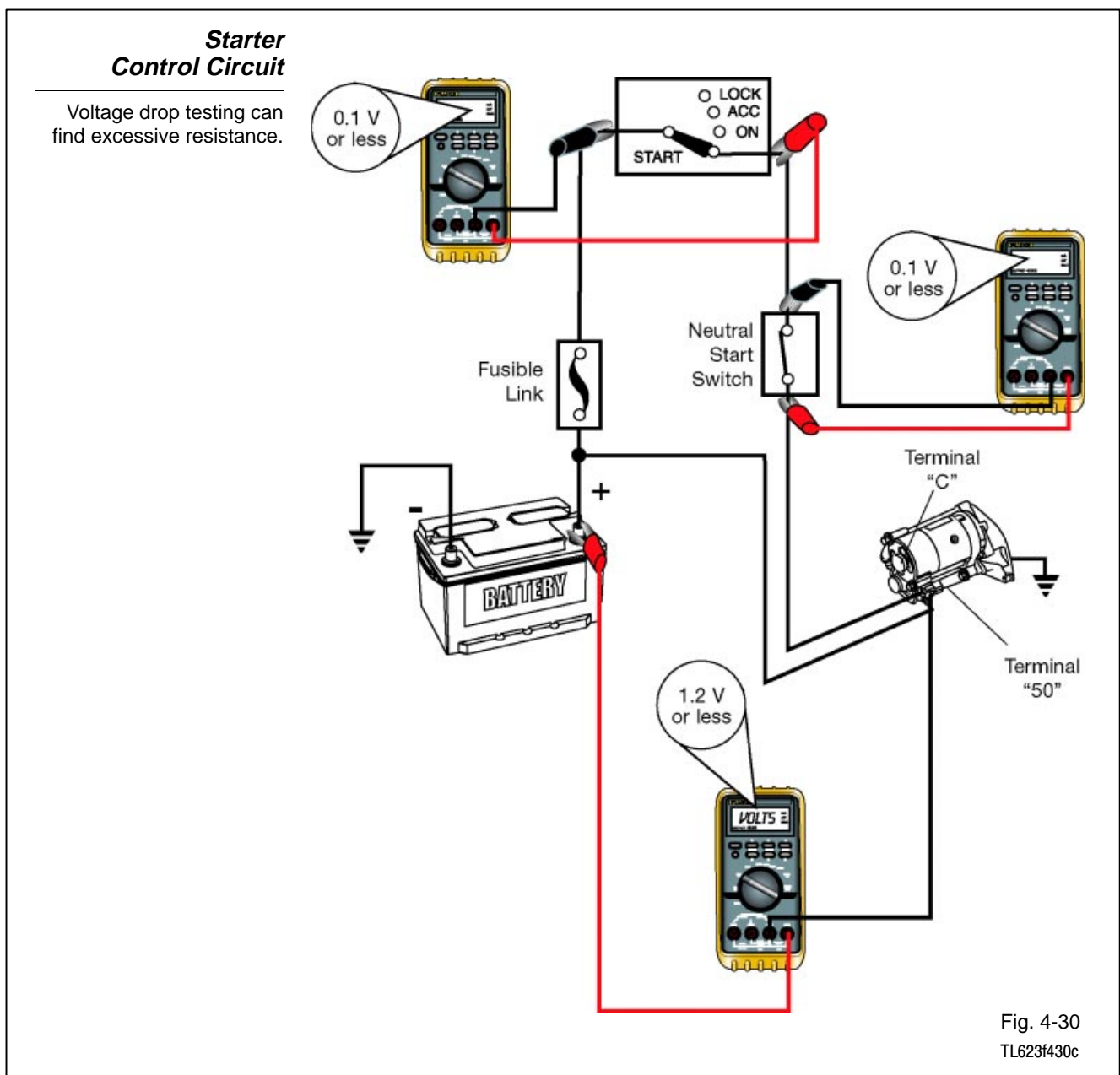

Test for excessive resistance in the starter control circuit with these steps:

1. Connect tester or meter leads -
 - Red lead to the positive battery terminal
 - Black lead to terminal 50 on the starter motor
2. On a vehicle with an automatic transmission, put the shift selector in Park or Neutral. For a vehicle with a manual transmission, depress the clutch pedal.

NOTE

Do not crank the engine longer than 10 seconds at a time.

3. Crank the engine and note the voltage reading:
 - 1.2 volts or less is acceptable
 - More than 1.2 volts is an indication of excessive resistance.
4. Measure the voltage drop across the ignition switch and the neutral start/clutch start switch:
 - 0.1 volts or less is acceptable
 - More than 0.1 volts is an indication of excessive resistance

If you find excessive resistance, perform these steps:

- Isolate the cause
- Repair the fault
- Re-test the voltage drop

Testing the Starter Relay

Testing the starter relay involves two steps:

1. Check for continuity with the relay de-energized.
2. Check for continuity with the relay energized.

Relay de-energized (2004 Camry starter relay in this example) -

- No continuity between pins 3 and 5 (through the open contacts)
- Continuity between pins 1 and 2 (through the relay coil)

NOTE

To energize the relay, connect two jumper wires:

- Battery positive to pin 1
- Battery negative to pin 2

Relay energized -

- Continuity between pins 3 and 5 (through the closed contacts)

If any of these checks do not produce the specified result, replace the relay.

Starter Relay Tests

Relays must be tested for continuity in both states: energized and de-energized.

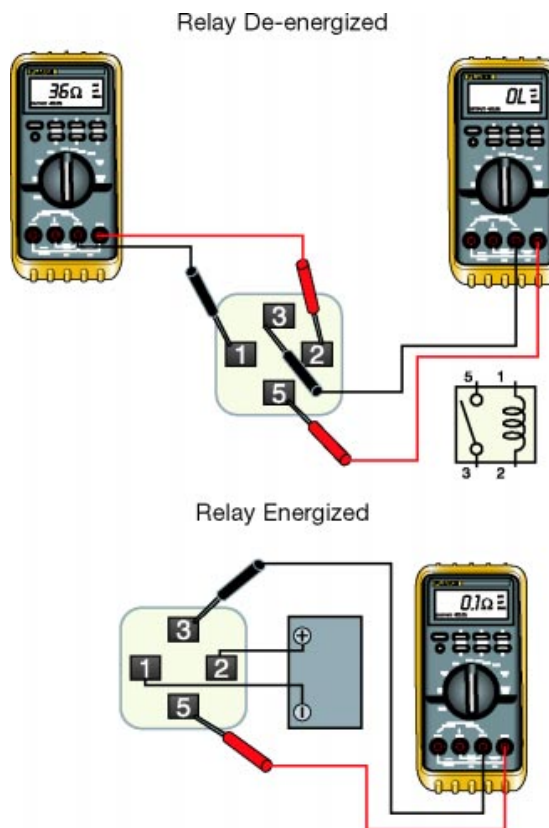

Fig. 4-31
TL623f431c

Ignition Switch and Key

Check the ignition switch both mechanically and electrically.

Mechanically - Switch should turn smoothly without binding. Binding may mean problems with the lock cylinder or the electrical contacts.

Check the ignition key for excessive wear or rough surfaces.

Electrically - Disconnect the battery ground cable and check for continuity through the ST contacts. Refer to the appropriate service manual for wiring details.

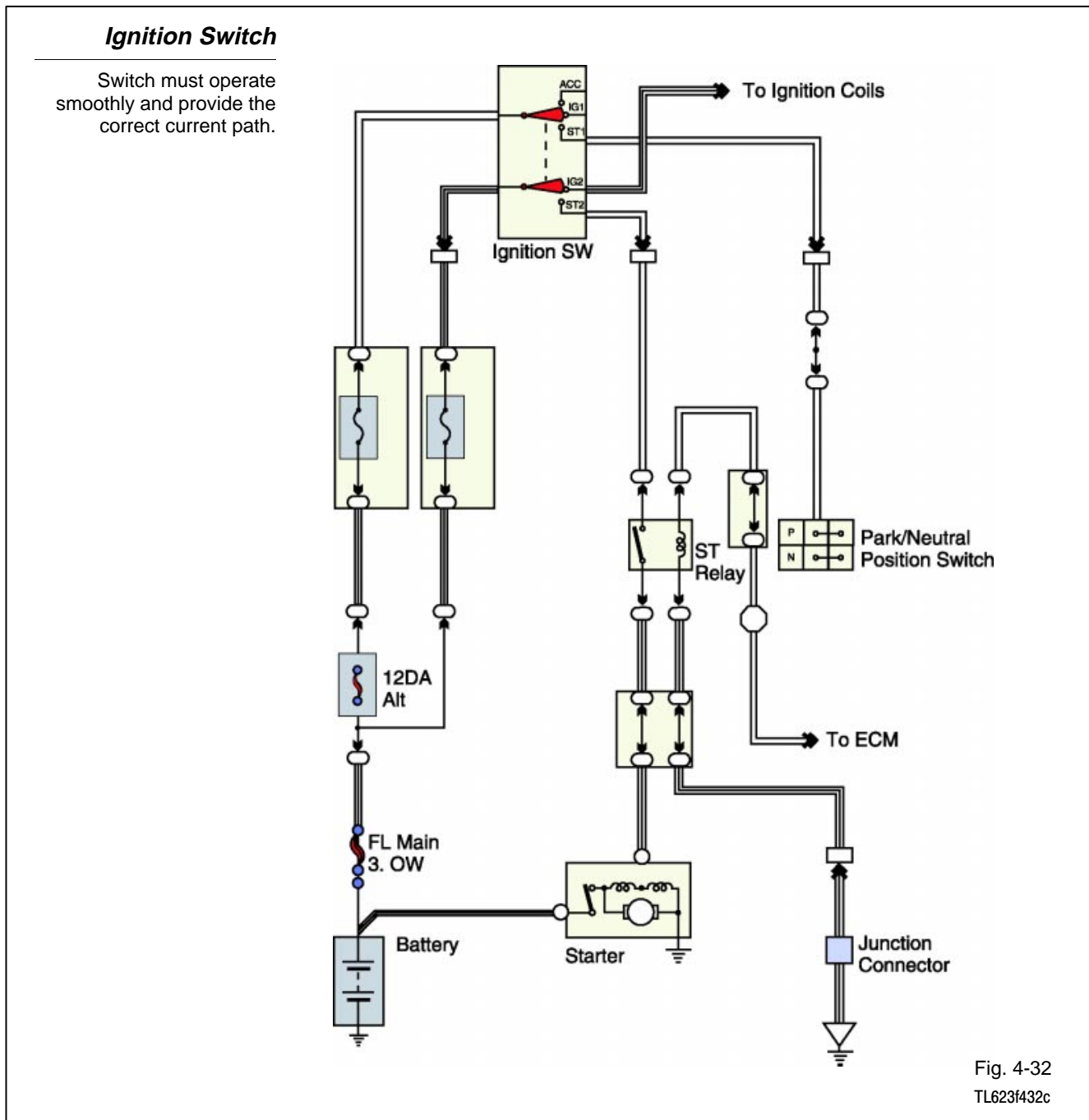

Park/Neutral Position Switch

Adjust the park/neutral position switch if you can operate the starter with the gear selector in any position other than Park or Neutral.

Adjust the switch as follows:

1. Loosen the switch retaining bolt.
2. Disconnect the switch electrical connector.
3. Set the gear selector to the Neutral position.
4. Connect an ohmmeter across the switch contacts (refer to the appropriate service manual for wiring details).
5. Adjust the switch to the point where the ohmmeter shows continuity.
6. Set the gear selector to Park; confirm that there is still continuity through the switch.
7. Set the gear selector to any position other than Park or Neutral. Confirm that there is no continuity through the switch.

Park/Neutral Position Switch

Switch may need adjustment if ignition switch operates starter with gear selector in any position other than Park or Neutral.

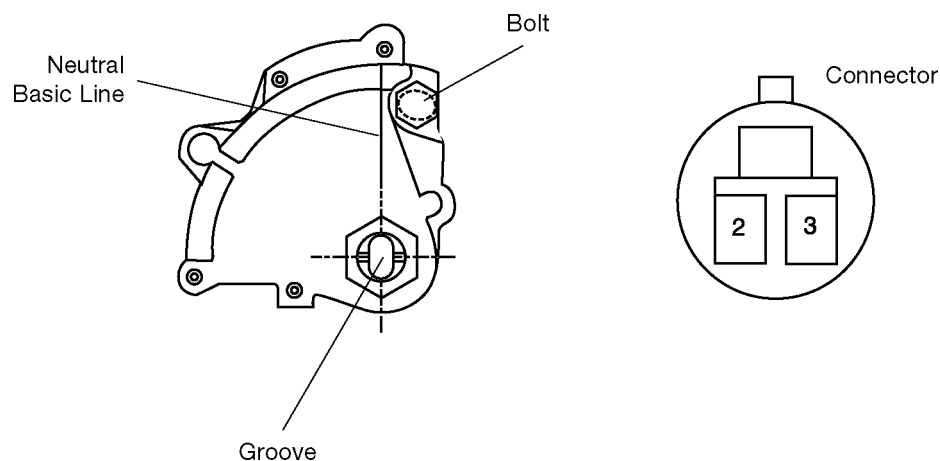

Fig. 4-33
TL623f433

Clutch Start Switch Adjust the Clutch Start Switch using the appropriate service manual. The procedure involves checking clutch pedal height and free-play in the switch.

Use a digital multimeter to check continuity through a properly adjusted switch:

Pedal depressed - There should be continuity through the switch with the clutch pedal depressed.

Pedal released - There should be no continuity through the switch with the clutch pedal released.

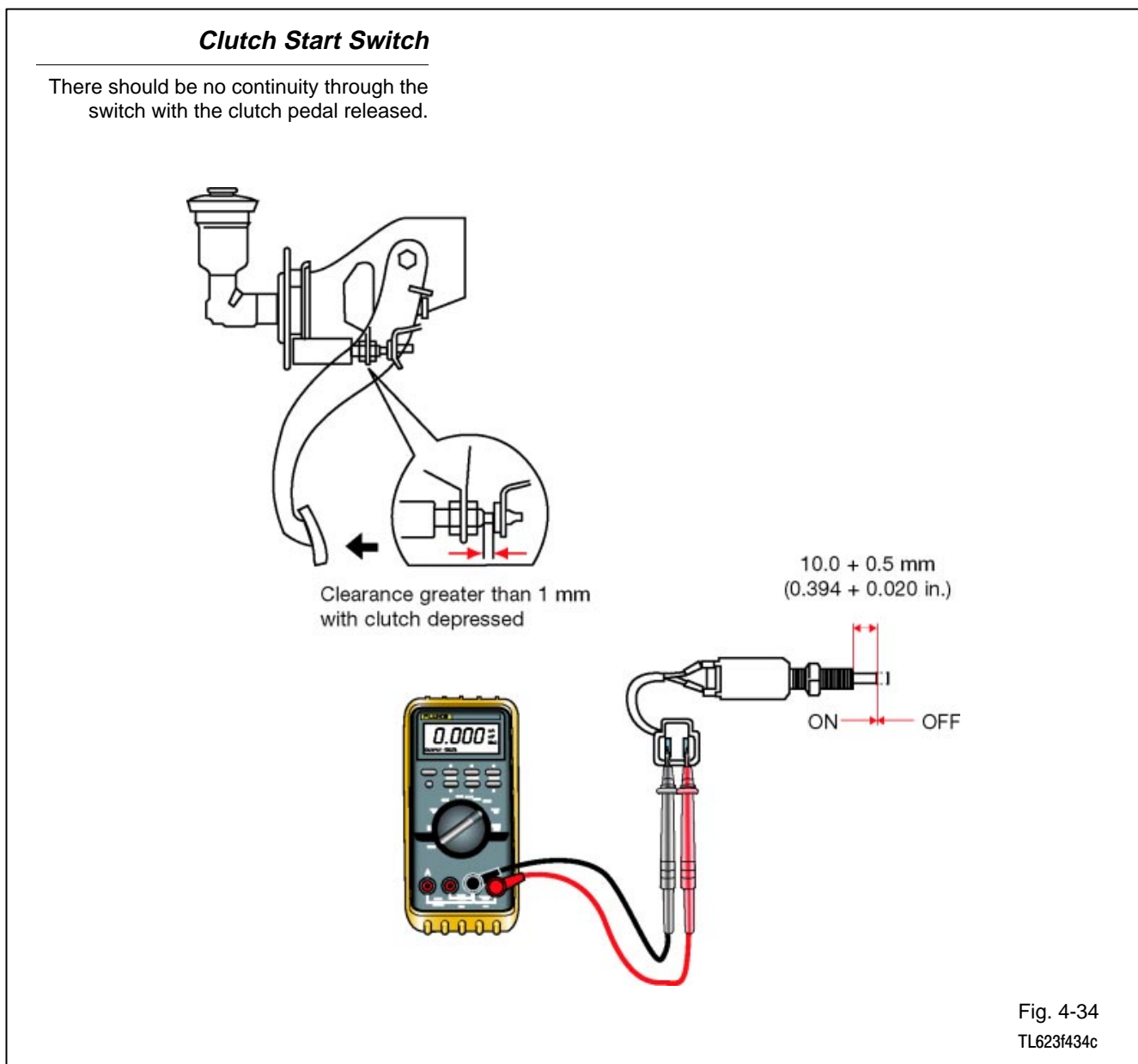

Clutch Start Cancel Switch Troubleshoot the Clutch Start Cancel Switch with these continuity and operational checks.

Continuity - Use a digital multimeter to confirm that there is no continuity between these terminals:

- 1 and 2
- 1 and 3
- 2 and 3

Replace the switch if you find continuity between any of these pairs of pins.

Operational - Connect a battery across pins 1 and 3. Use a digital multimeter to check for continuity as follows:

- no continuity between pins 1 and 2 with switch OFF
- continuity between pins 1 and 2 with switch ON

Replace the switch if either of these tests gives a continuity result different from the specification.

Clutch Start Cancel Switch

Switch must be tested with continuity checks and operational checks.

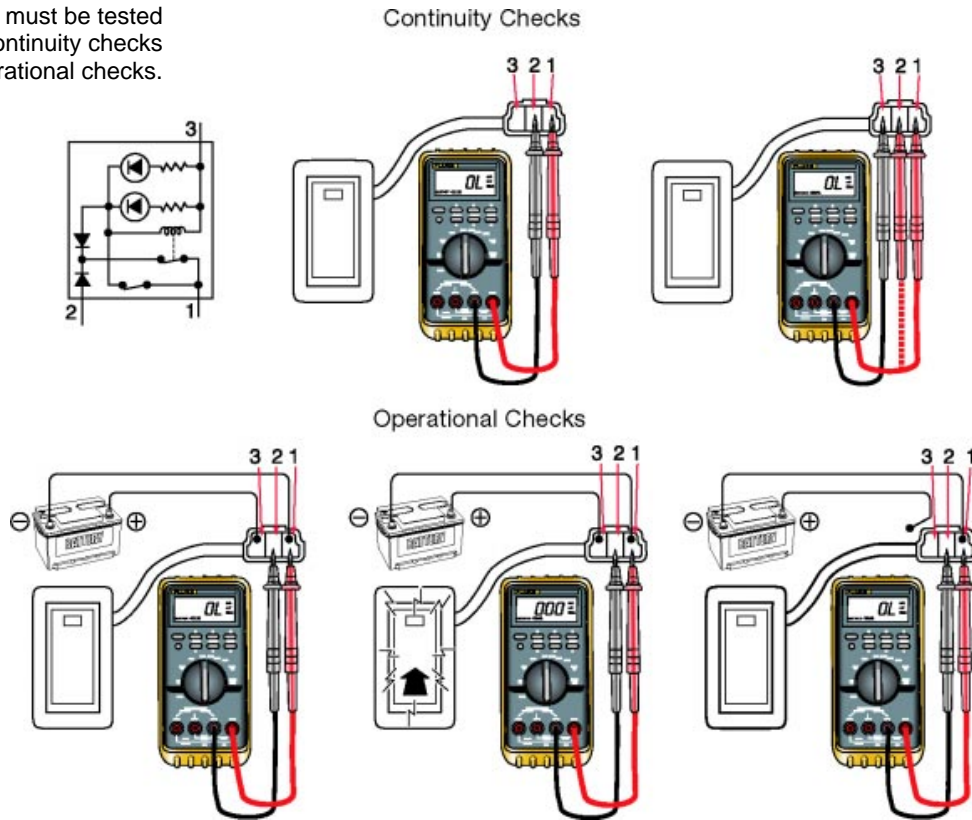

Fig. 4-35
T623f435c



WORKSHEET 4-1
Starting System Components

Worksheet Objectives

When you have completed this worksheet, you will be able to identify and name the components that make up the starting system.

Tools and Equipment

For this exercise you will need the following:

- Technician's Handbook
- Repair Manual/EWD

Exercise 1: Identifying and Naming Components

Refer to the starting system diagram in Figure 4W1-1. Match the numbers on the drawing to the correct component names below:

- 1. _____ 6. _____
- 2. _____ 7. _____
- 3. _____ 8. _____
- 4. _____ 9. _____
- 5. _____ 10. _____

Exercise 2: Associating Component and Function

Refer to the list you made in Exercise 1. Match each of these functions with the associated component. Write the component's number in front of the function statement:

- _____ Provides electrical power to operate the starter motor.
- _____ Closes to allow current flow to the pull-in and hold-in coils.
- _____ Closes when current flows through the pull-in coil to provide a large current flow from the battery through the starter motor to ground.
- _____ (More than one component) Opens when excessive current flows in the circuit.
- _____ Closes when the gear selector is in Neutral or Park.

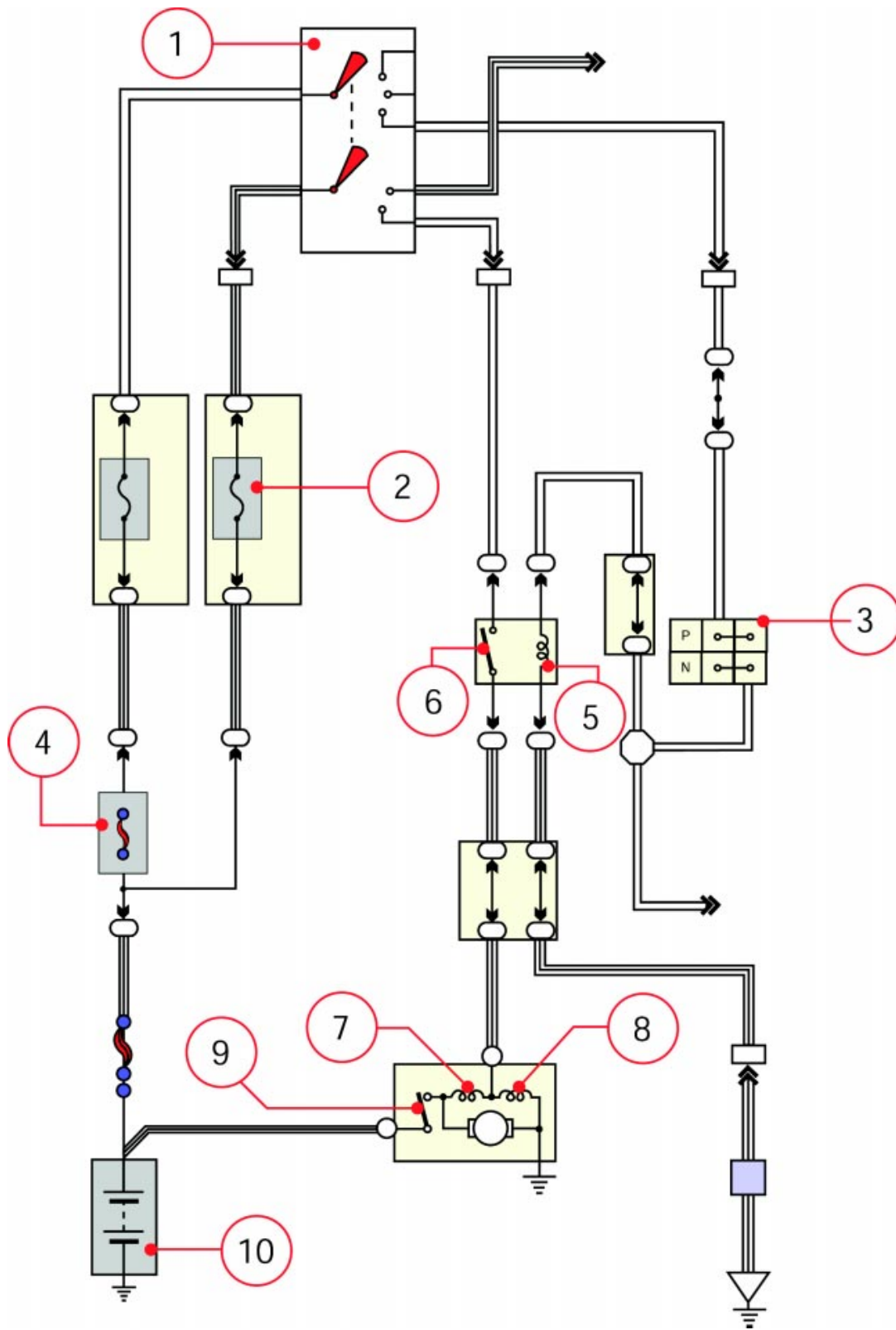
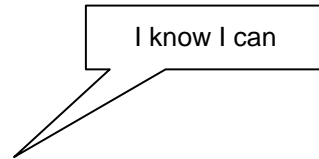
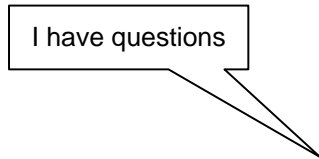

Fig. 4W1-1
TL623f001c-4W1

Starting System Components

Name: _____ Date: _____

Review this sheet as you are doing the Starting System Components worksheet. Check each category after viewing the instructor’s presentation and completing the worksheet. Ask the instructor if you have questions regarding the topics provided below. Additional space is provided under topic for you to list any other concerns that you would like you instructor to address. The comments section is provided for your personal comments, information, questions, etc.



Topic	Comment		
Identify Starting System Components			
Associate Components with Function			



Notes



WORKSHEET 4-2
PS Starter Internal Components

Worksheet Objectives

When you have completed this worksheet, you will be able to identify and name the components of Planetary Reduction Segment Conductor (PS) type starters.

Tools and Equipment

For this exercise you will need the following:

- Technician's Handbook
- Repair Manual/EWD

Exercise 1: Identifying and Naming the Components of a Starter

Refer Figure 4W2-1. Match the numbers on the drawing to the correct component names below:

1. _____
2. _____
3. _____
4. _____

Exercise 2: Associating Component and Function

Determine whether each of the following statements about PS starters is true or false. Write your answer in the blank space in front of each statement.

_____ Planetary reduction gears allow the starter motor to operate at a lower speed than a conventional starter motor.

_____ The purpose of the reduction gear set is to reduce pinion gear speed compared to motor shaft speed.

_____ Segment conductor type starters are more compact than conventional starter motors.

_____ Segment conductor type starters are heavier than conventional starter motors.

_____ Segment conductor type starters provide greater output torque than conventional starter motors.

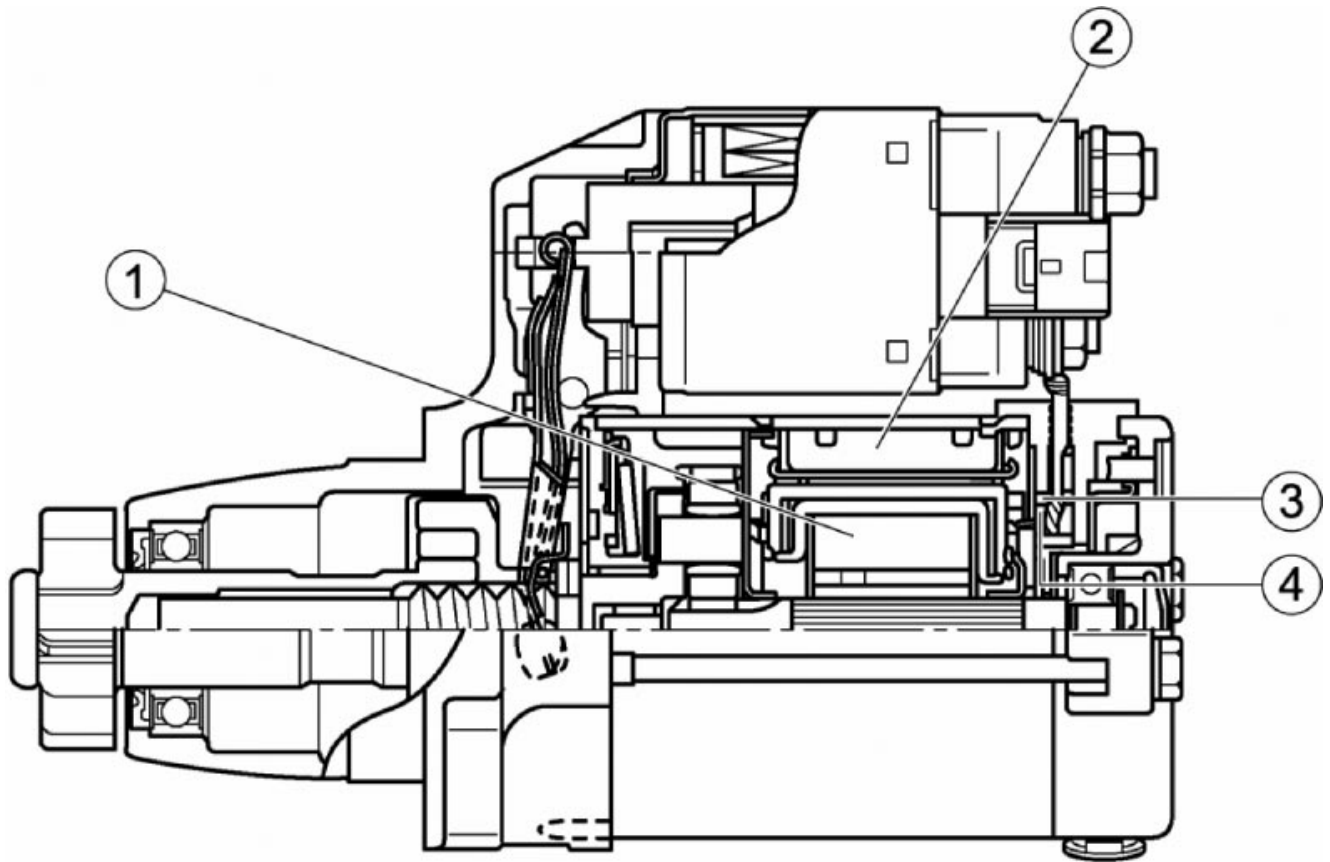

Fig. 4W2-1
TL623f001-4W2

PS Starter Internal Components

Name: _____ Date: _____

Review this sheet as you are doing the PS Starter Internal Components worksheet. Check each category after viewing the instructor’s presentation and completing the worksheet. Ask the instructor if you have questions regarding the topics provided below. Additional space is provided under topic for you to list any other concerns that you would like your instructor to address. The comments section is provided for your personal comments, information, questions, etc.

I have questions

I know I can

Topic			Comment
Identify Starter Components			
Associate Component with Function			



Notes



WORKSHEET 4-3

Current Flow in the Starting System

Worksheet Objectives

When you have completed this worksheet, you will be able to show how current flows in the starting system.

Tools and Equipment

For this exercise you will need the following:

- Technician's Handbook
- Repair Manual/EWD
- Pens or highlighters (red/pink and green).

Exercise 1: Ignition Switch to START

Refer to Figure 4W3-1. The conditions in the circuit are as follows:

- Ignition switch turned to the START position
- Park neutral switch closed
- Start relay coil energized
- Start relay contact closed
- Pull-in and hold-in coils energized
- Magnetic switch contact closed

Use a highlighter (red or pink for power, green for ground) to trace current flow in these paths. Show each path from voltage source to ground:

1. Through the Start relay coil
2. Through the Start relay contact
3. Through the magnetic switch contact

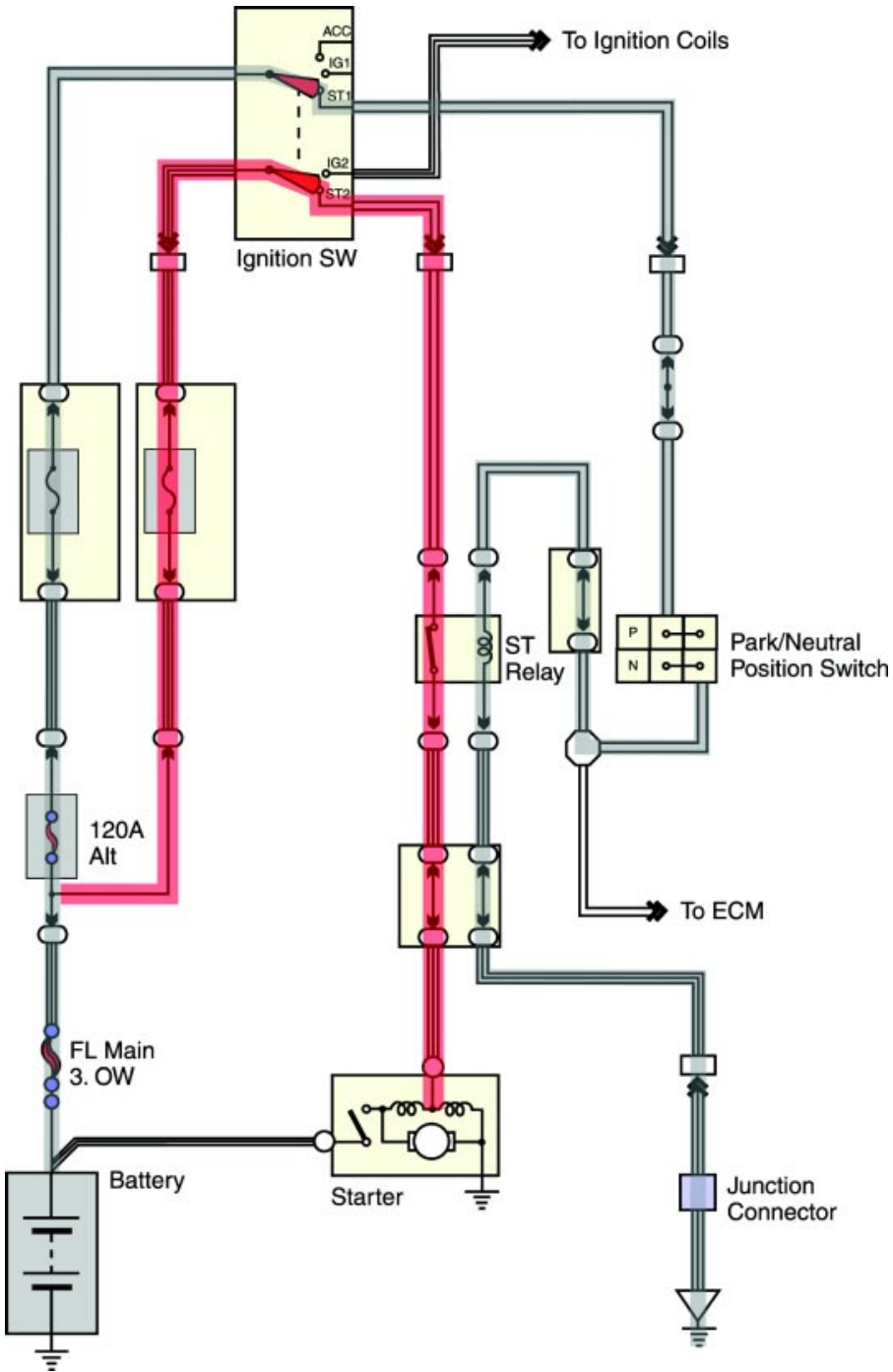

Fig. 4W3-1
TL623f001c-4W3

Exercise 2: Ignition Switch to ON

Refer to the Figure 4W3-2. The ignition switch has just returned to the ON position immediately after engine start.

State the conditions in the circuit; answer by checking the appropriate condition for each statement:

- | | |
|---------------------|--|
| Park neutral switch | <input type="checkbox"/> Open |
| | <input type="checkbox"/> Closed |
| ST Relay coil | <input type="checkbox"/> Energized |
| | <input type="checkbox"/> Not energized |
| ST relay contact | <input type="checkbox"/> Open |
| | <input type="checkbox"/> Closed |
| Pull-in coil | <input type="checkbox"/> Energized |
| | <input type="checkbox"/> Energized, reverse current flow |
| | <input type="checkbox"/> Not energized |
| Hold-in coil | <input type="checkbox"/> Energized |
| | <input type="checkbox"/> Not energized |
| Magnetic switch | <input type="checkbox"/> Open |
| | <input type="checkbox"/> Closed |

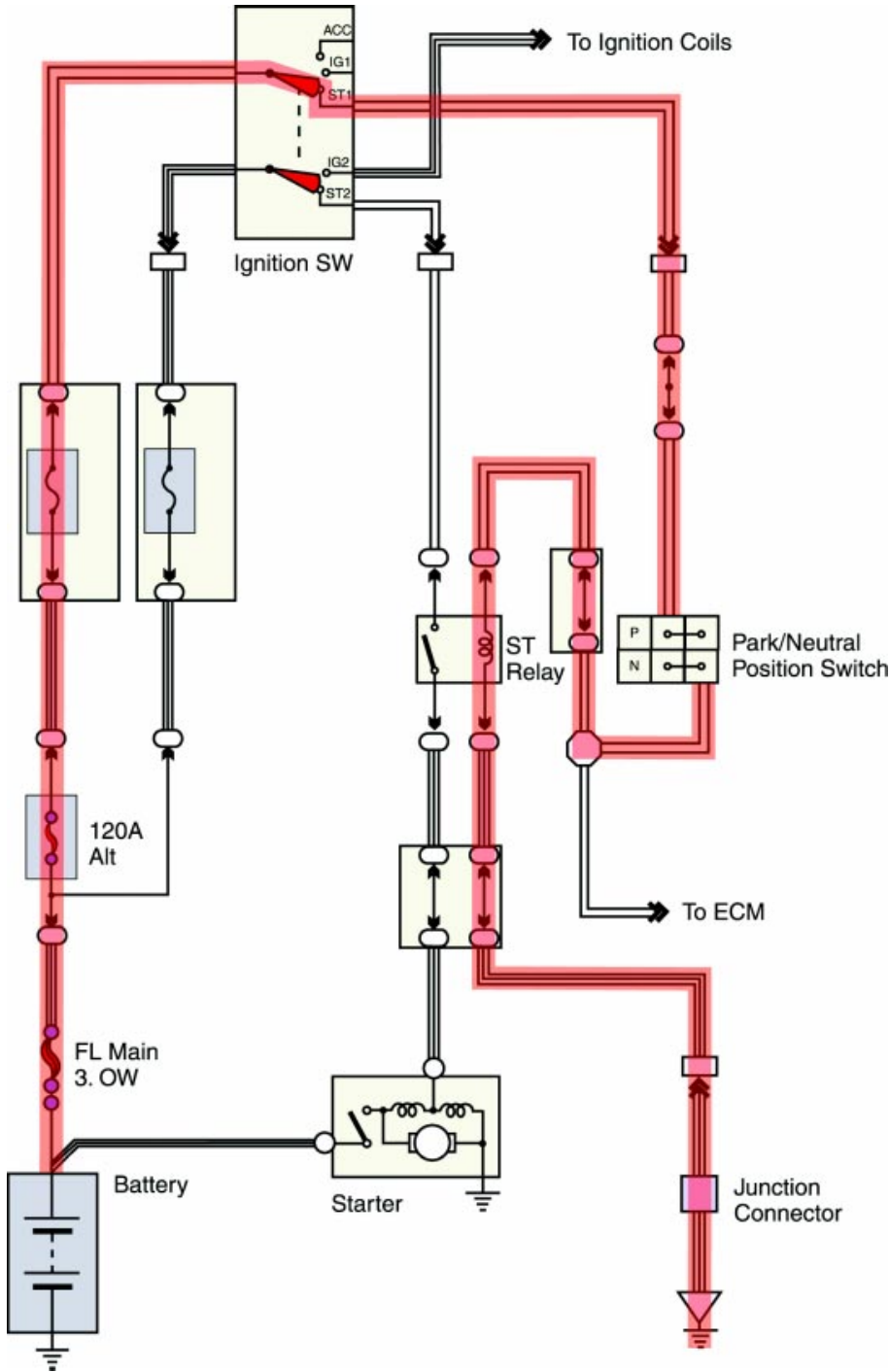

Fig. 4W3-2
TL623f002c-4W3

Current Flow in the Starting System

Name: _____ Date: _____

Review this sheet as you are doing the Current Flow in the Starting System worksheet. Check each category after viewing the instructor's presentation and completing the worksheet. Ask the instructor if you have questions regarding the topics provided below. Additional space is provided under topic for you to list any other concerns that you would like your instructor to address. The comments section is provided for your personal comments, information, questions, etc.

I have questions

I know I can

Topic	Comment		
Trace Current Flow			



Notes



WORKSHEET 4-4
Starting System Visual Inspection

Vehicle	Year/Prod. Date	Engine	Transmission
---------	-----------------	--------	--------------

Worksheet Objectives

When you have completed this worksheet, you will be able to demonstrate a visual inspection of the starting system on an actual vehicle.

Tools and Equipment

For this exercise you will need the following:

- Technician’s Handbook
- Vehicle
- Repair Manual/EWD

Exercise 1: Visual Inspection

Caution - The battery contains sulfuric acid. Take precautions to avoid possible injury or damage to the vehicle:

- Remove rings, wristwatch, and any jewelry.
- Wear safety glasses and protective clothing.

Inspect each component on the list below. Describe the condition of each item you inspected in the table below:

Inspection Item	Condition
Battery	
Starter motor	
Neutral start switch	
Clutch start switch	
Ignition switch	

Starting System Visual Inspection

Name: _____ Date: _____

Review this sheet as you are doing the Starting System Visual Inspection worksheet. Check each category after viewing the instructor's presentation and completing the worksheet. Ask the instructor if you have questions regarding the topics provided below. Additional space is provided under topic for you to list any other concerns that you would like your instructor to address. The comments section is provided for your personal comments, information, questions, etc.

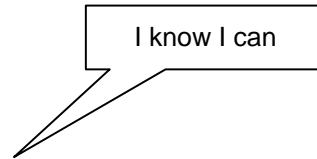
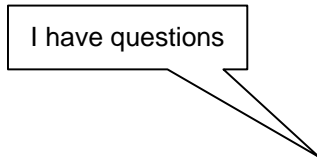

Topic	Comment		
Visual Inspection			



WORKSHEET 4-5 *Starter Current Draw Test*

Vehicle	Year/Prod. Date	Engine	Transmission
---------	-----------------	--------	--------------

Worksheet Objectives

When you have completed this worksheet, you will be able to demonstrate a starter current draw test.

Tools and Equipment

For this exercise you will need the following:

- Technician's Handbook
- Repair Manual / EWD
- Vehicle
- VAT-40 or VAT-60 Tester

Exercise 1: Current Draw Test

1. Turn off all electrical accessories and lights in the vehicle; set ignition switch to OFF.
2. Disable the fuel or ignition system so engine will not start while cranking. (e.g. remove EF 1 main relay)
3. Connect the tester in this sequence:
 - Red lead to positive battery terminal
 - Black lead to negative battery terminal
 - Current probe
4. For VAT-40, set the voltage selector to INT 18 (volts).
 - Set "Test Selection" to position #1 "Starting."
 - Adjust Ammeter to zero.
5. Without cranking the engine, note the voltage reading.
 - Should be at least 12.6 volts
 - Recharge the battery before proceeding if the voltage is below 12.6 volts

Note - Do not crank the engine longer than 10 seconds at a time.

6. Crank the engine and observe the voltage and current readings.

7. Record the test values in the blank spaces below:

Cranking current draw _____ Amps

Cranking voltage _____ Volts

Starter passed test? _____ Yes

_____ No

8. When finished with the test, disconnect the tester leads and restore the vehicle to its original condition (replace fuse or relay).

Starter Current Draw Test

Name: _____ Date: _____

Review this sheet as you are doing the Starter Current Draw Test worksheet. Check each category after viewing the instructor's presentation and completing the worksheet. Ask the instructor if you have questions regarding the topics provided below. Additional space is provided under topic for you to list any other concerns that you would like your instructor to address. The comments section is provided for your personal comments, information, questions, etc.

I have questions

I know I can

Topic	Comment		
Current Draw Test			



Notes



WORKSHEET 4-6
Starting System Voltage Drop Testing

Vehicle	Year/Prod. Date	Engine	Transmission
---------	-----------------	--------	--------------

Worksheet Objectives

When you have completed this worksheet you will be able to demonstrate measuring voltage drops in the starting system.

Tools and Equipment

For this exercise you will need the following:

- Technician's Handbook
- EWD (or TIS)
- DMM or VAT 40 (or equivalent)
- Vehicle (as assigned)

Exercise 1: Preparation

1. Locate the starting system circuit for your assigned vehicle in TIS or the EWD.
2. Set the DMM to measure DC voltage (auto range or 20 volt scale).
3. Locate the EFI or Fuel pump fuse (or relay) to disable engine starting.
4. Use the DMM to measure voltage drops in the starting circuit applicable to your vehicle. Conduct the voltage drop test by cranking the engine and note the reading on the DMM. Write the readings in the chart below.

Caution: Do not crank the engine for more than 10 seconds at a time. Longer cranking periods can damage the starter and related components.

Location	Voltage Drop
Positive battery post to battery cable	_____
Positive battery cable to starter	_____
Starter relay to starter (if equipped)	_____
Terminal C to terminal 30 (if equipped)	_____
Positive battery cable to terminal 50 (if equipped)	_____
Positive battery cable to starter ground	_____
Starter ground to negative battery cable	_____
Negative battery cable to negative battery post	_____

5. Are any of the test results out of range? YES / NO (circle one)

If YES, list here along with possible cause of the condition:

6. Reinstall the EFI fuse or fuel pump relay.

7. Start the vehicle and run for 2-5 minutes to recharge the battery.

Starting System Voltage Drop Testing

Name: _____ Date: _____

Review this sheet as you are doing the Starting System Voltage Drop Testing worksheet. Check each category after viewing the instructor's presentation and completing the worksheet. Ask the instructor if you have questions regarding the topics provided below. Additional space is provided under topic for you to list any other concerns that you would like your instructor to address. The comments section is provided for your personal comments, information, questions, etc.

I have questions

I know I can

Topic	Comment		
Measure Voltage Drop			



Notes



WORKSHEET 4-7
Starter Relay Test

Vehicle	Year/Prod. Date	Engine	Transmission
---------	-----------------	--------	--------------

Worksheet Objectives

When you have completed this worksheet, you should be able to test the starter relay for proper operation.

Tools and Equipment

For this exercise you will need the following:

- Technician's Handbook
- Vehicle
- DMM
- Repair Manual/EWD

Exercise 1: Continuity Checks

1. Check the electrical wiring diagram for the vehicle you are testing. Note the terminal assignments for the starter relay connector.

For the coil: _____

For the contacts: _____

2. Set up the DMM to check continuity:
 - Mode selector knob to Ohms
 - Auto-range on
 - Black lead inserted into COM input jack
 - Red lead inserted into Volt/Ohm/Diode input jack

3. Remove the starter relay.

4. Measure continuity through the relay:

Through the coil _____ ohms

Through the contacts _____ ohms

5. Use a set of jumper wires and the power supply from the electrical simulator to apply battery voltage across the relay coil.

6. Measure continuity through the relay contacts only (do not apply the meter leads to the coil with voltage applied).

Record your measurement here: _____ ohms

Does the relay pass the continuity checks? _____ Yes _____ No

7. Re-install the relay in its socket when you have finished the test.

Starter Relay Test

Name: _____ Date: _____

Review this sheet as you are doing the Starter Relay Test worksheet. Check each category after viewing the instructor's presentation and completing the worksheet. Ask the instructor if you have questions regarding the topics provided below. Additional space is provided under topic for you to list any other concerns that you would like you instructor to address. The comments section is provided for your personal comments, information, questions, etc.

I have questions

I know I can

Topic	Comment		
Check Continuity			



Notes

Section 5

The Charging System

Charging System

The charging system has two essential functions:

- Generate electrical power to run the vehicle's electrical systems
- Generate current to recharge the vehicle's battery

Electrical power - At low engine speeds, the battery may supply some of the power the vehicle needs. At high engine speeds, the charging system handles all of the vehicle's electrical requirements.

Charging - Alternator (generator) output is higher than battery voltage to recharge the battery.

Charging System

The alternator supplies power for the vehicle when the engine is running and engine speed is above idle.

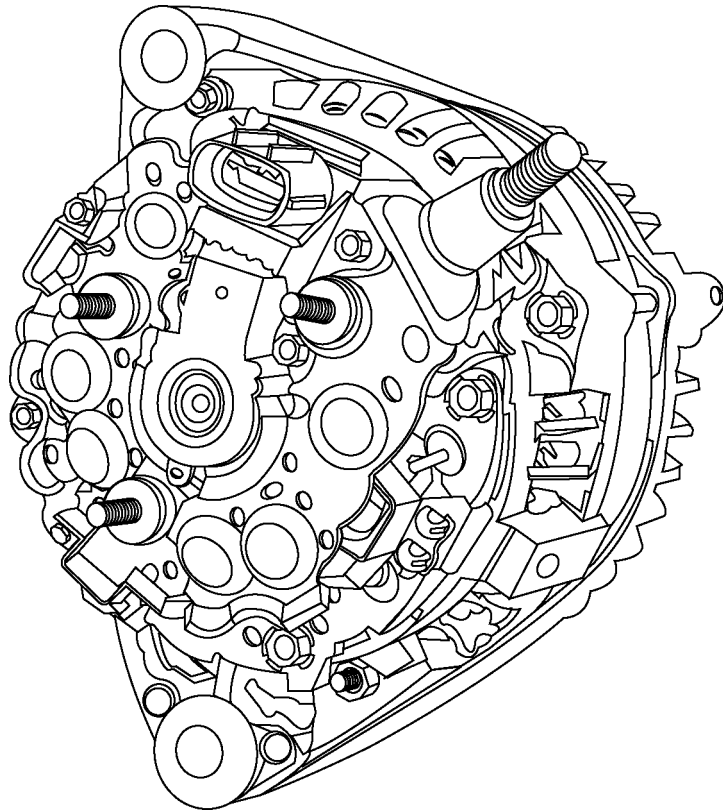

Fig. 5-01
TL623f501

Charging System Components

These components make up the charging system:

- Alternator
- Voltage regulator
- Battery
- Charging indicator

Charging System Components

This figure shows the major components of the charging system.

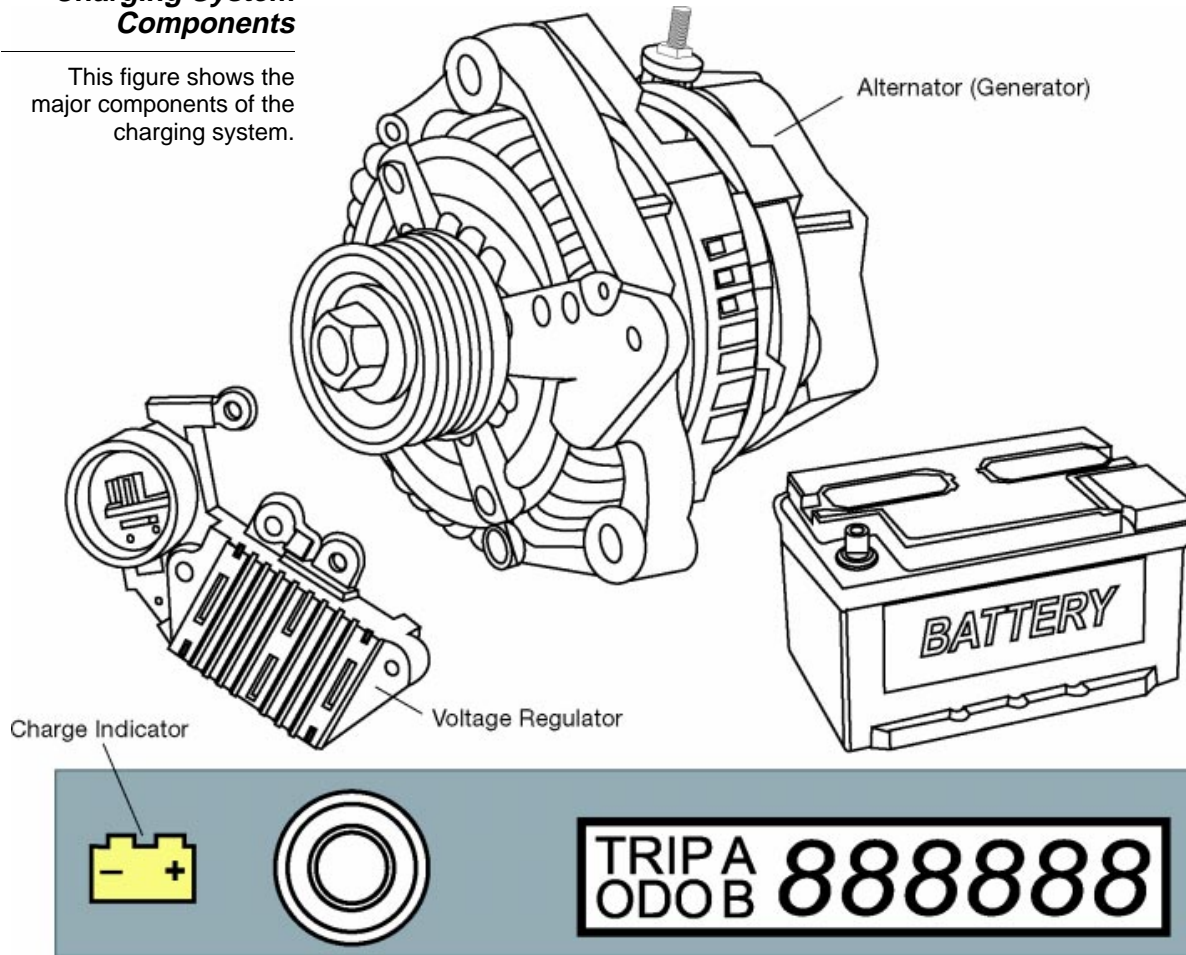

Fig. 5-02
TL623f500

Alternator The alternator contains these main components:

- Stator (attached to alternator housing, remains stationary)
- Rotor (spins inside the stator)
- Rectifier
- Voltage regulator

Slip rings and brushes make an electrical connection to the spinning rotor.

The alternator generates electricity through these steps:

- Engine power drives the alternator rotor through a pulley and drive belt.
- The alternator rotor spins inside the windings of the stator.
- The stator windings generate an alternating current.
- Rectifier diodes change the alternating current (AC) into direct current (DC).

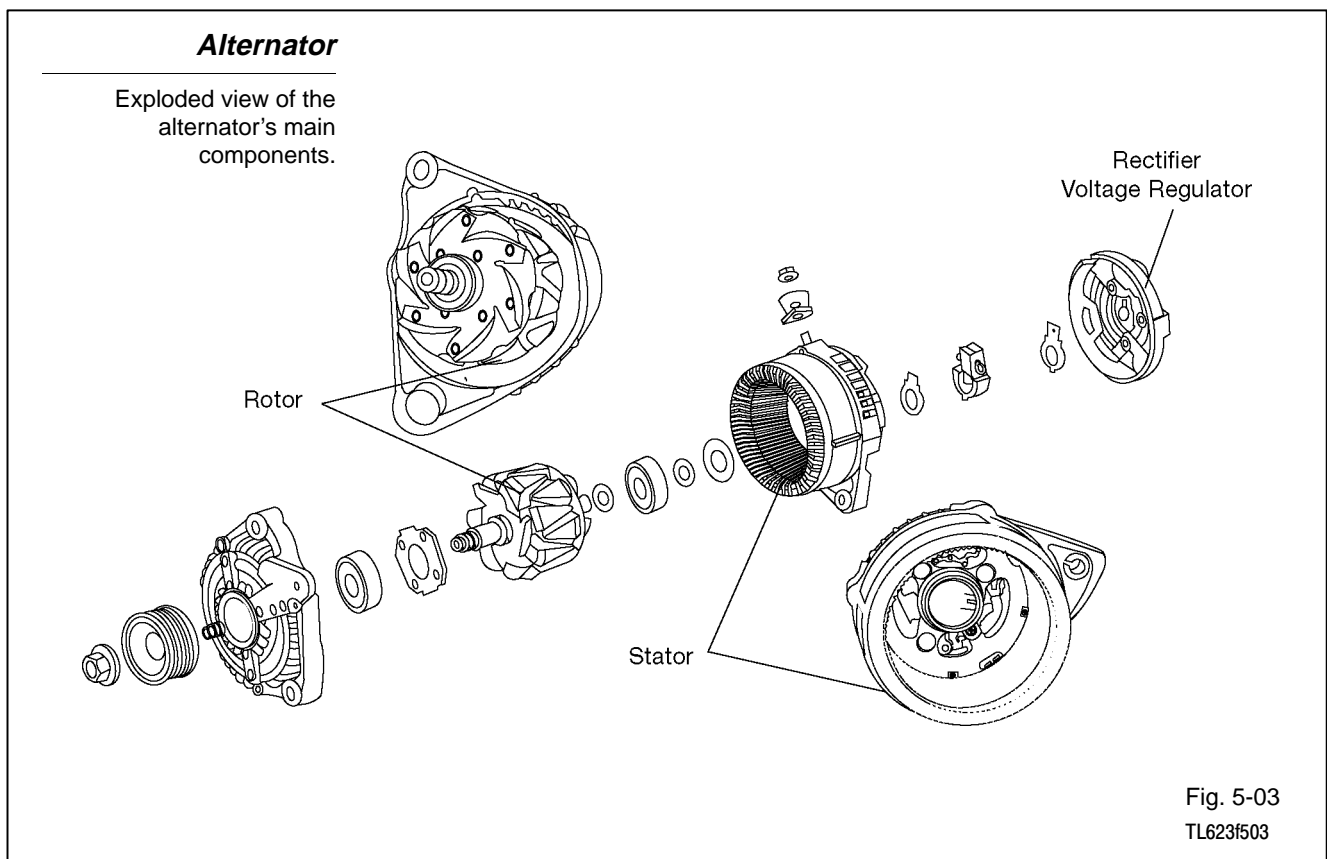

Voltage Regulator The voltage regulator controls the alternator's output current to prevent over-charging and under-charging of the battery. It does this by regulating the current flowing from the battery to the rotor's field coil.

Today's IC voltage regulator is a fully electronic device, using resistors and diodes.

Voltage Regulator

The voltage regulator controls the alternator's output current.

Voltage Regulator

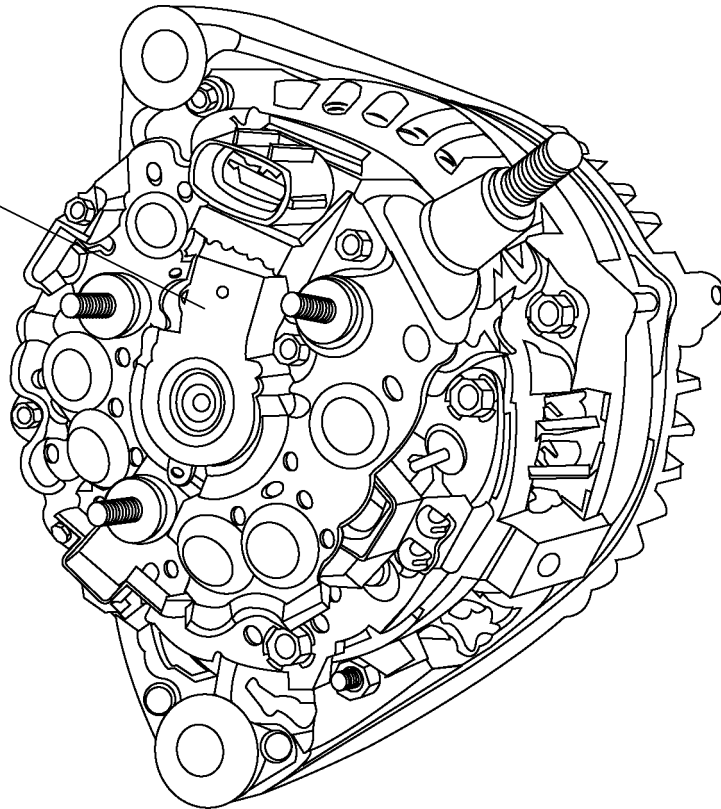

Fig. 5-04
TL623f504

Battery The battery supplies current to energize the alternator field coil. The battery also acts as a voltage stabilizer. The battery must always remain attached to the electrical system while the engine is running.

Battery

The battery supplies current to energize the alternator's field coil.

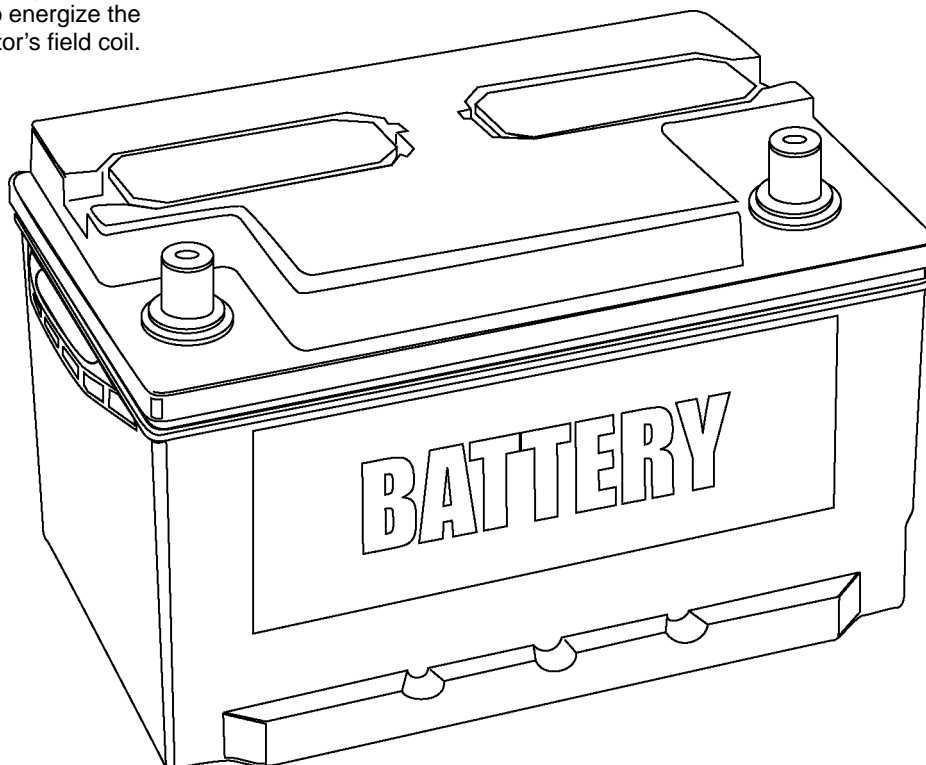

Fig. 5-05
TL623f505

Charging Indicator The charging indicator is usually an ON/OFF warning lamp. When the system is running, the light should be OFF. The lamp lights when the charging system is not providing sufficient charge.

Charging Indicator

The charging indicator lights when the charging system is not supplying enough power to charge the battery.

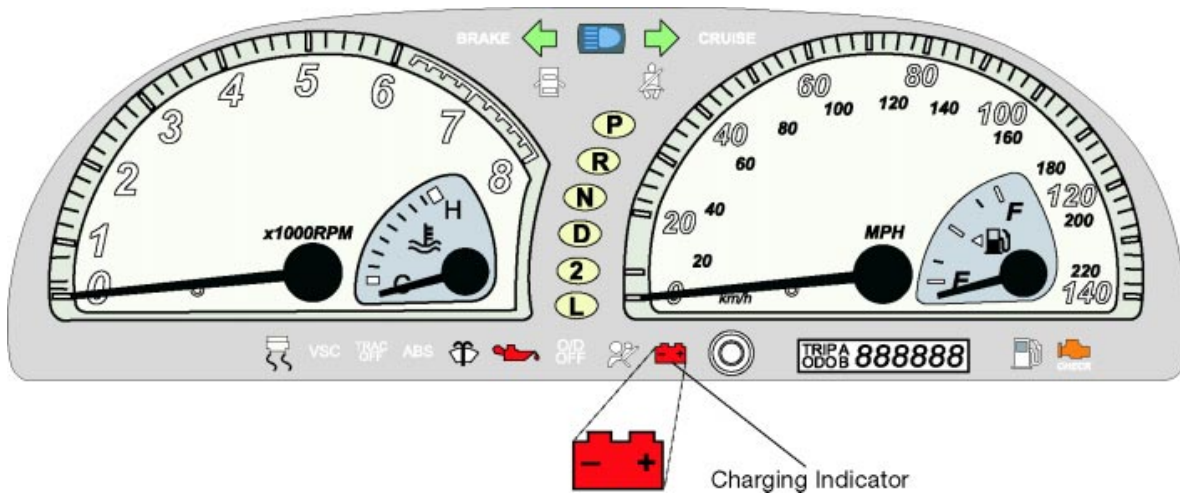

Fig. 5-06
TL623f506c

Charging System Operation

Current in the charging system changes for these three different operating conditions:

- Ignition switch to ON - engine stopped
- Ignition switch to ON - engine running alternator output below desired voltage
- Ignition switch to ON - engine running alternator output above desired voltage

Ignition switch to ON - engine stopped:

- As soon as the ignition switch is turned to ON, the IC regulator causes a current of about 0.2 amps through the rotor's field coil.
- The IC regulator turns on the charging indicator.
- There is no output from the stator because the rotor is not turning.

Ignition Switch to ON - Engine Stopped

The IC regulator causes a small current through the alternator rotor field coil.

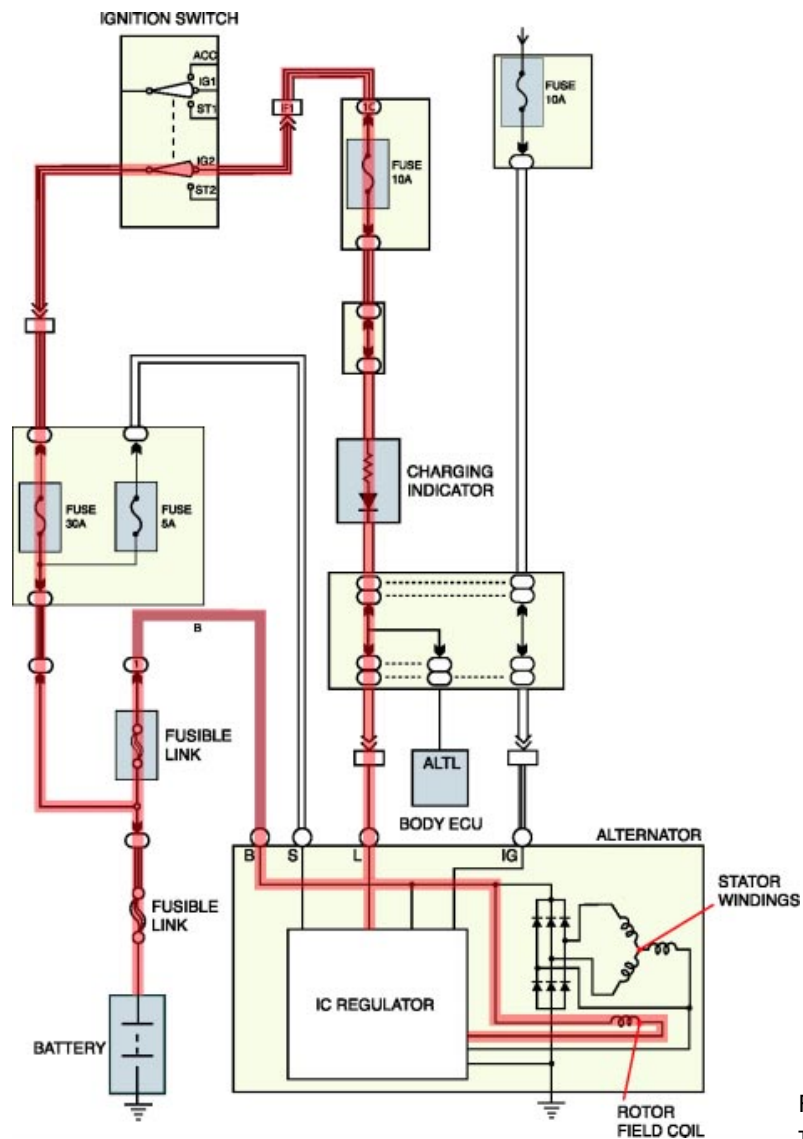

Fig. 5-07
TL623f507c

Ignition switch to ON - engine running, alternator output below desired voltage:

- The windings in the stator generate a voltage any time the rotor is energized and spinning.
- Voltage generated in the stator is applied to the voltage regulator.
- If the alternator output voltage is below 14.5 volts, the voltage regulator responds by increasing current through the field coil of the rotor. This causes the voltage to increase.
- A charging current is sent to the battery.

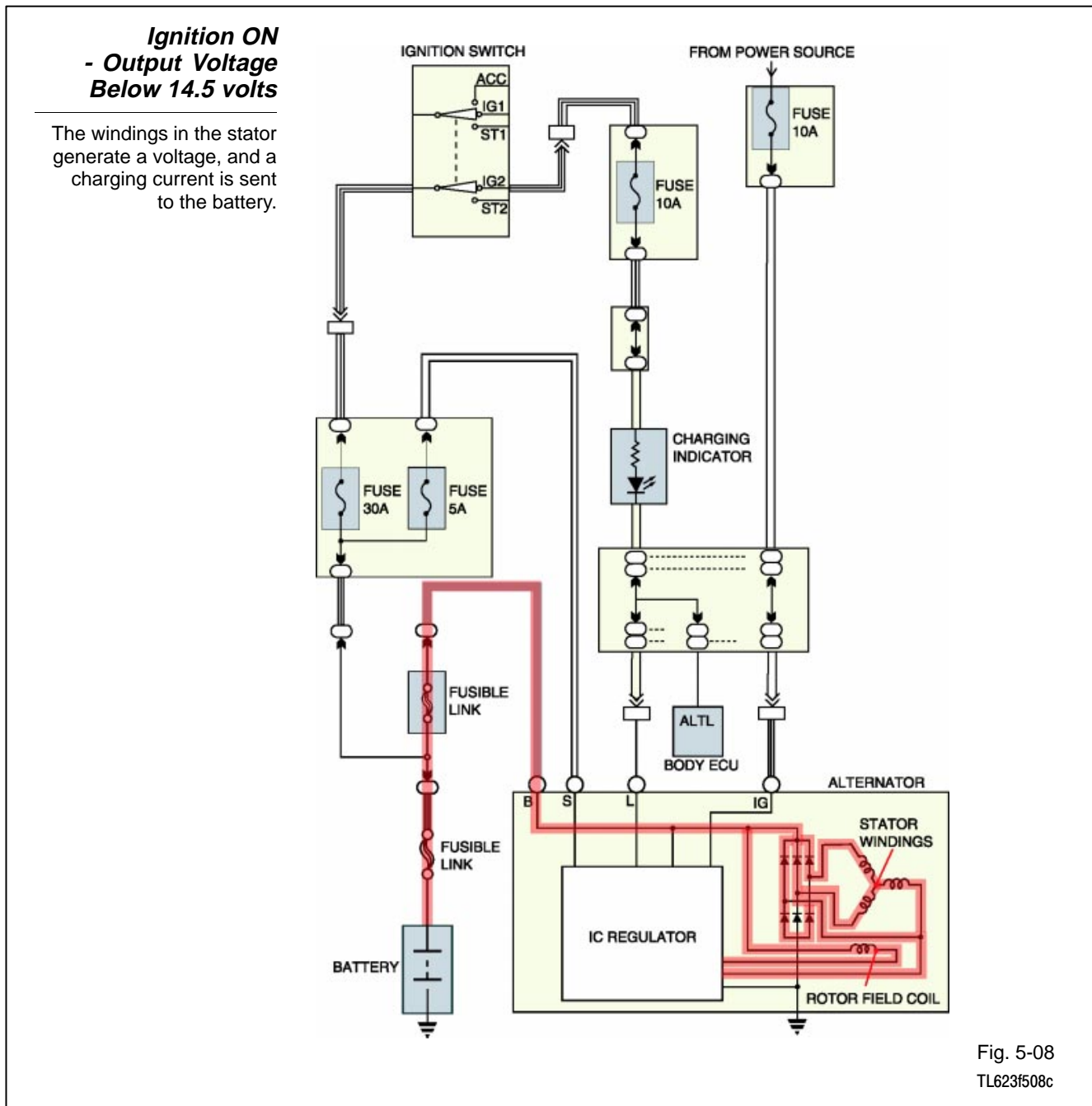
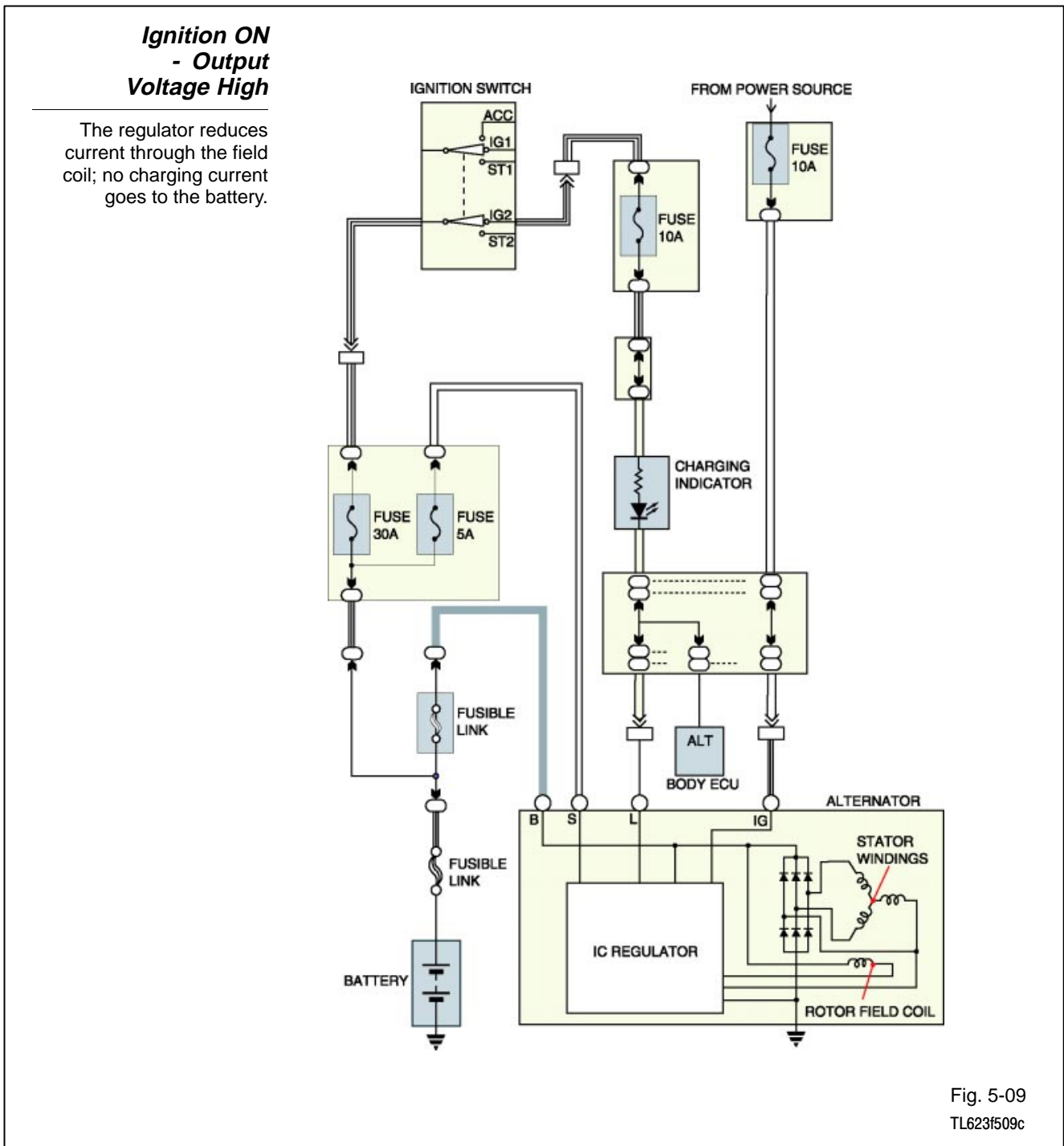

Fig. 5-08
TL623f508c

Ignition switch to ON - engine running alternator output above desired voltage:

When the voltage regulator senses alternator output at or above 14.5 volts:

- It reduces current through the rotor field coil.
- This reduces alternator output voltage.
- No charging current goes to the battery.



Safeguards are built into the alternator in case the connection to Terminal B or Terminal S is lost:

- Terminal S is an input to the regulator to monitor voltage levels.
- Terminal B is alternator output.

Terminal S disconnected:

- The voltage regulator does not detect voltage.
- The voltage regulator regulates voltage at Terminal B to 16 volts and lights the Charging Indicator.

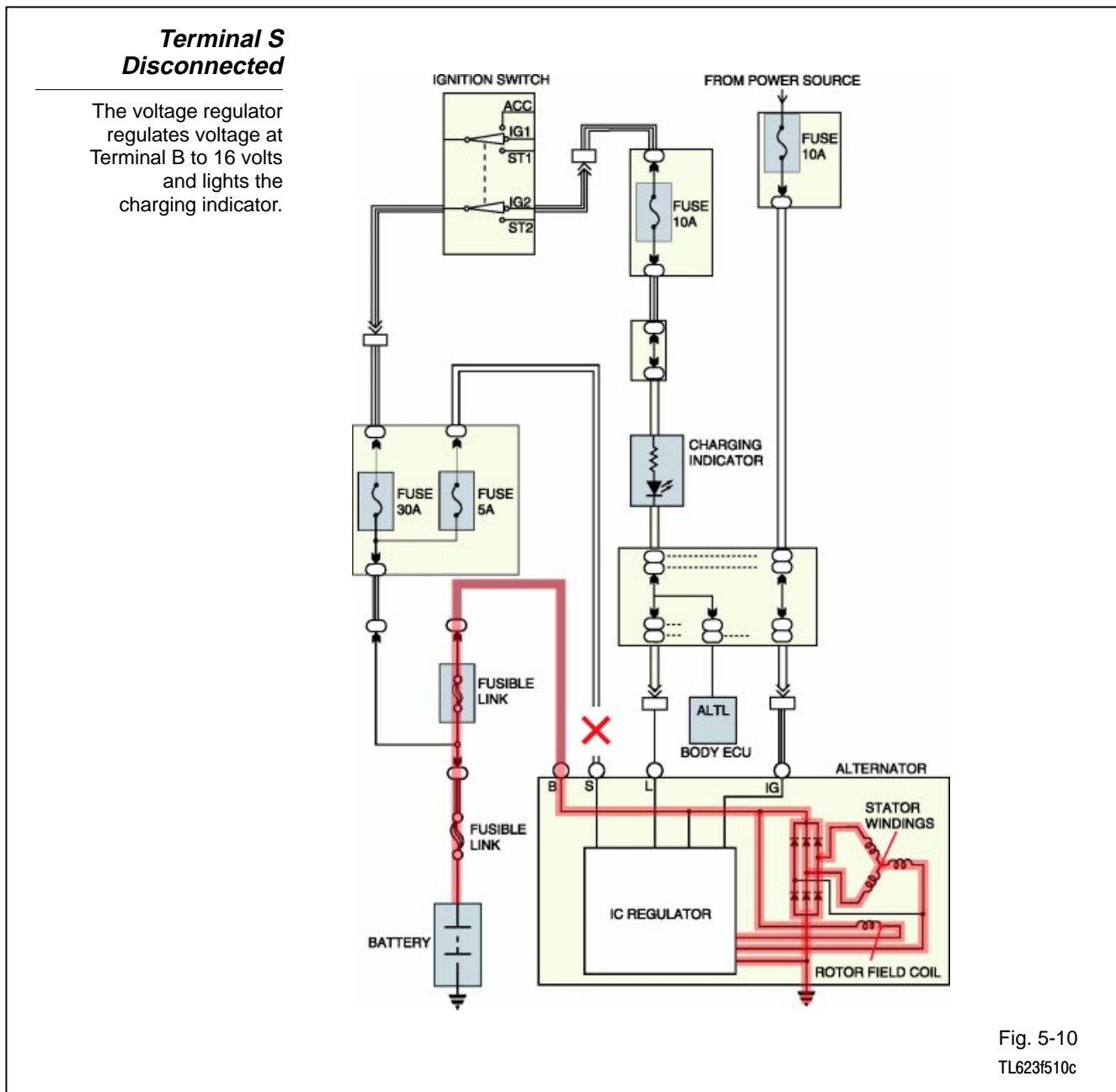

Fig. 5-10
TL623f510c

Diagnosis and Testing The charging system requires little maintenance. The battery should be fully charged and connections kept clean and tight.

Diagnosis of charging system problems is typically straightforward. Problems may be electrical or mechanical.

The troubleshooting flow diagram on the next page lists the most common charging system problems, the possible cause, and recommended actions to resolve the problem.

Begin with a thorough visual inspection. If this fails to turn up the possible cause, several tests are available to help you find the problem:

- Alternator output test (no load)
- Alternator output test (with load)
- Voltage drop tests
- Charging current relay test
- Diode tests

Troubleshooting Flow Diagram Use this flow diagram to troubleshoot charging systems with compact, high speed alternators.

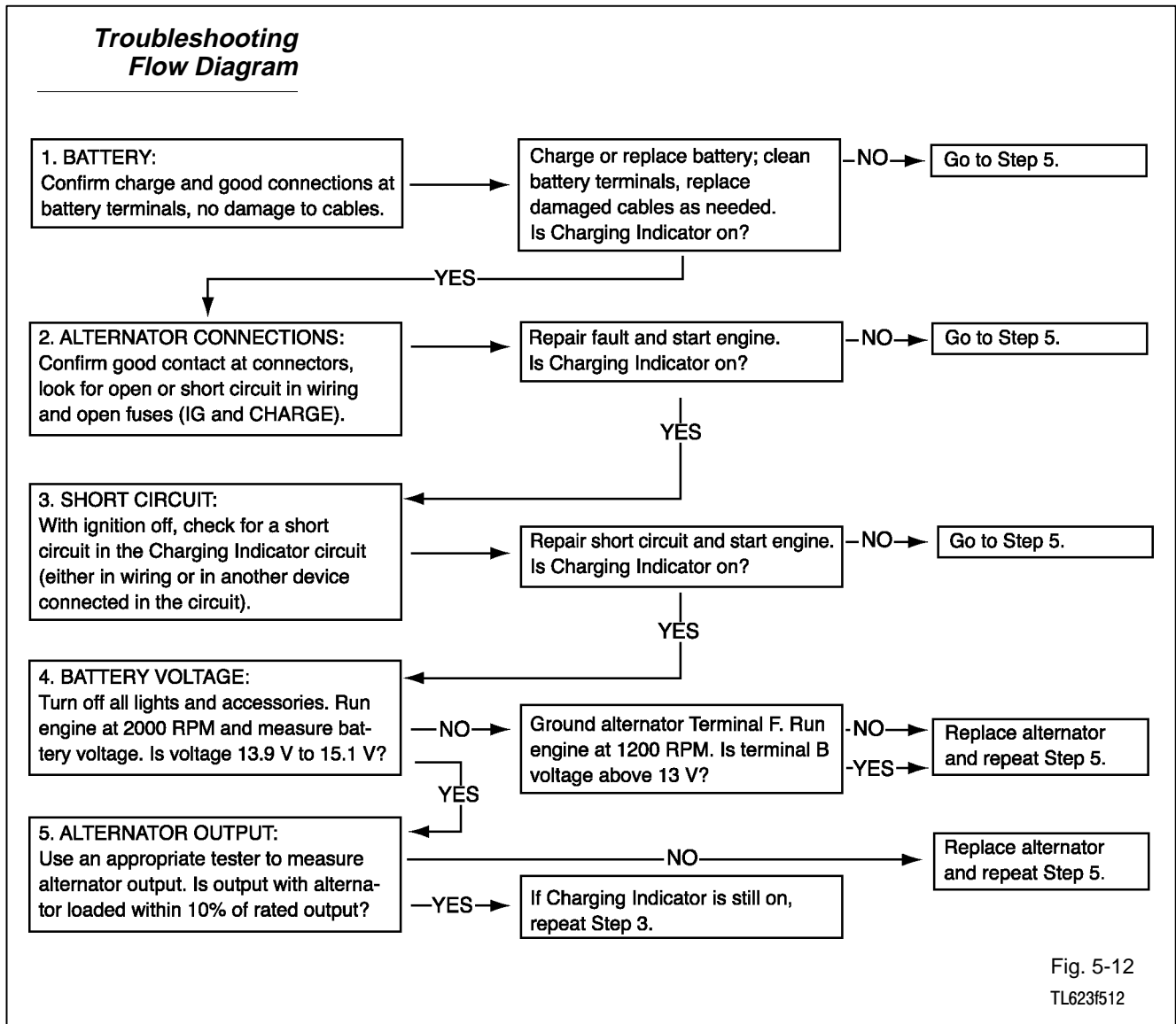
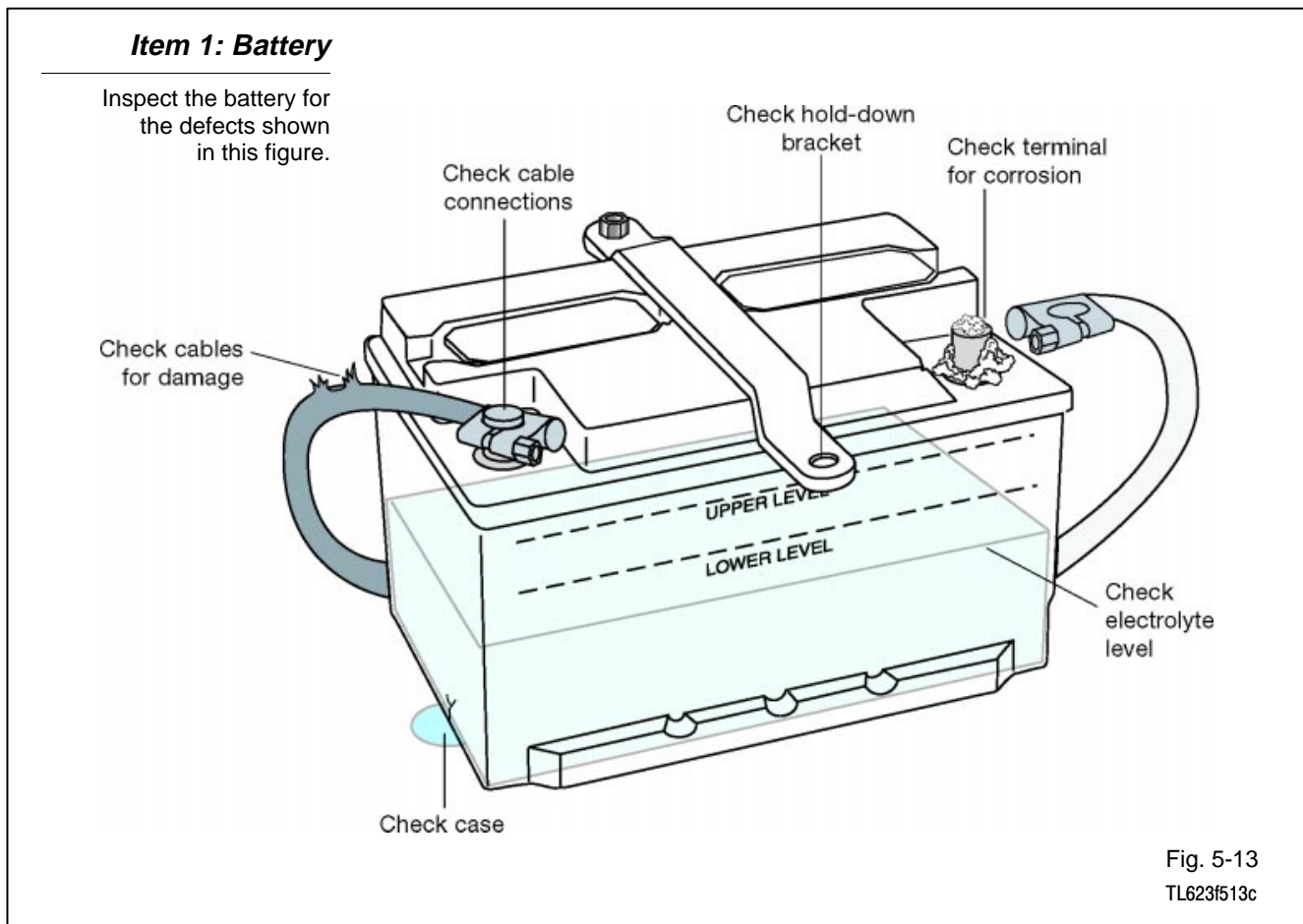

Fig. 5-12
TL623f512

**Charging System
Visual Inspection**

Include the following items in a visual inspection of the charging system:

1. Battery
2. Fusing
3. Alternator Drive Belt
4. Alternator Wiring
5. Noise
6. Charging Indicator



Other Battery Checks

State of Charge - Check the specific gravity of the electrolyte to determine the battery's state of charge.

- Specific gravity should be between 1.25 and 1.27 (at 80°F/26.7°C).

Condition - Check overall battery condition with a battery analyzer.

Other Battery Checks

A hydrometer can tell you the battery's state of charge.

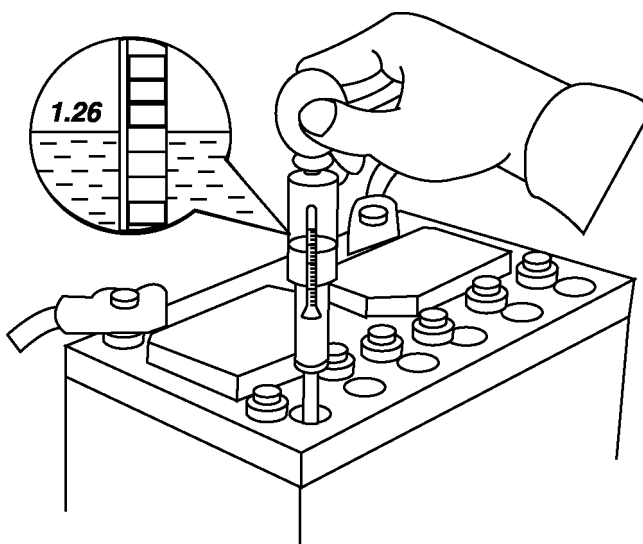

Fig. 5-14
TL623f514

Item 2: Fusing

- Refer to the EWD to identify fuses and fusible links in the charging system for the vehicle under test.
- Check these components for continuity.

Item 2: Fusing

Fusible links must be part of the visual inspection of the charging system.

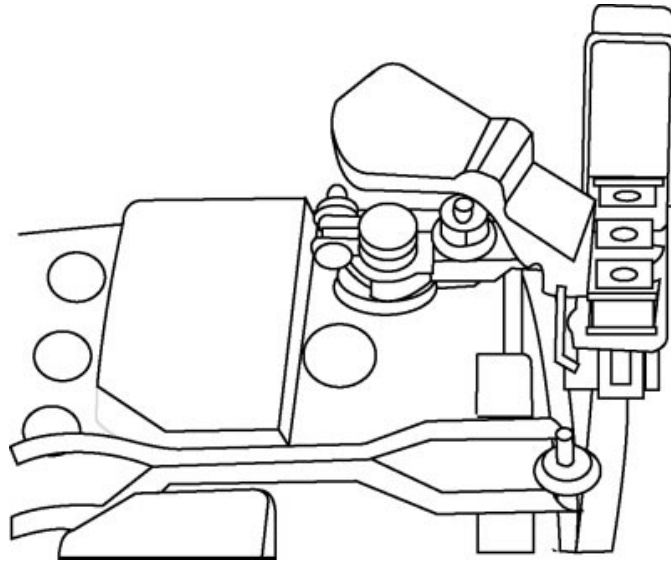

Fig. 5-15
TL623F515

Item 3: Alternator Drive Belt

- Good condition
- Correct alignment
- Proper tension

Item 3: Alternator Drive Belt

Alternator drive belts must be in good condition and be properly aligned and tensioned.

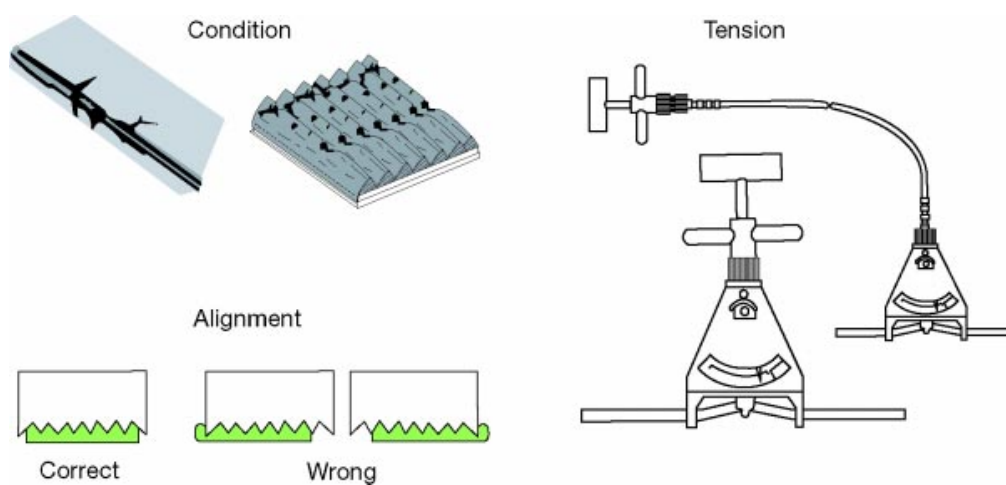

Fig. 5-16
TL623f516c

Item 4: Alternator Wiring

- Make sure all connections are clean and tight.
- Check wiring for frayed insulation and other physical damage.

Item 4: **Alternator Wiring**

Inspect wires and connections at the alternator.

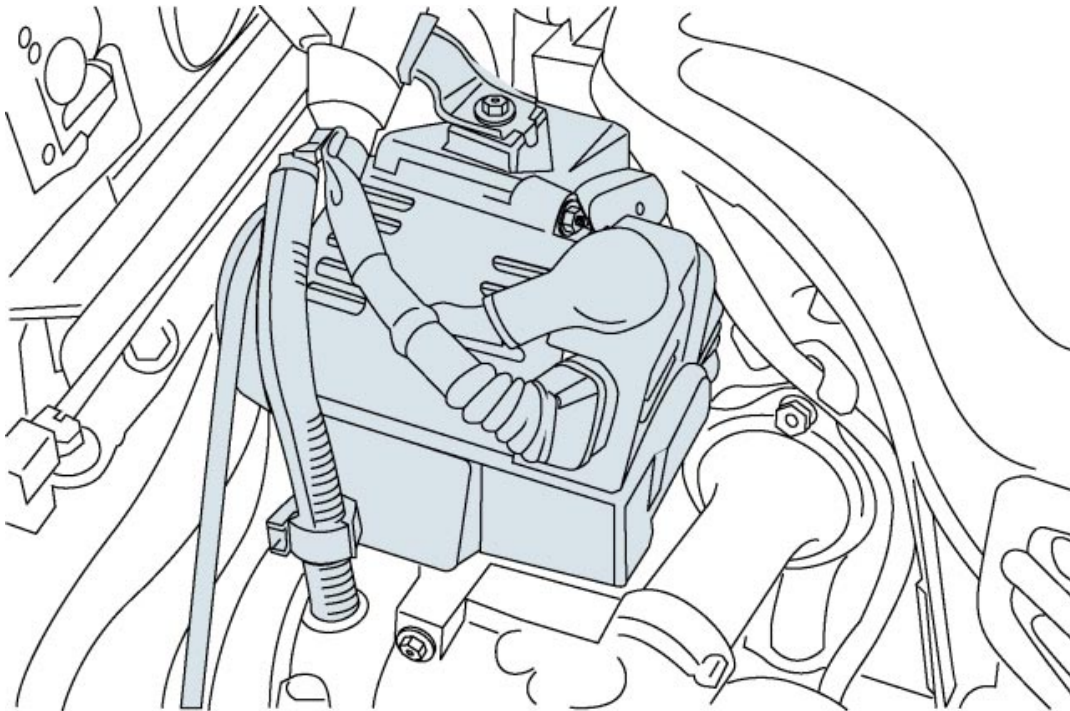

Fig. 5-17
TL623F517

Item 5: Alternator Noise

Listen for any unusual noise while the alternator is operating:

- Squealing may indicate a bearing problem or a worn or improperly tensioned and adjusted drive belt.
- Hissing may be a sign that one or more of the diodes are defective, because of a pulsating magnetic field and vibration.

Item 5: Alternator Noise

Alternator noise may be important in diagnosing potential problems.

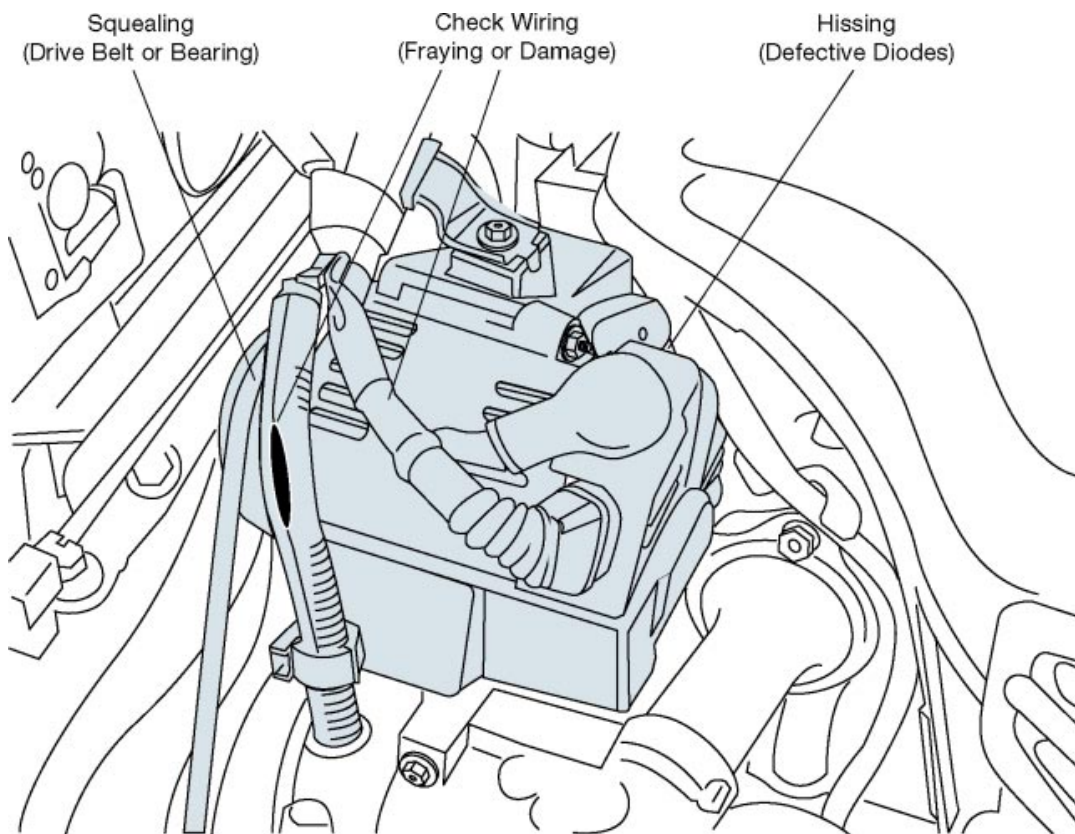

Fig. 5-18
TL623f518

Item 6: Charging Indicator

- Indicator lights with ignition ON and engine not running.
- Indicator goes off with engine running.

If the indicator does not operate as described above, refer to the appropriate EWD and check the indicator circuit.

**Item 6:
Charging
Indicator**

The Charging indicator should be on with the ignition on and the engine not running and off with the engine running.

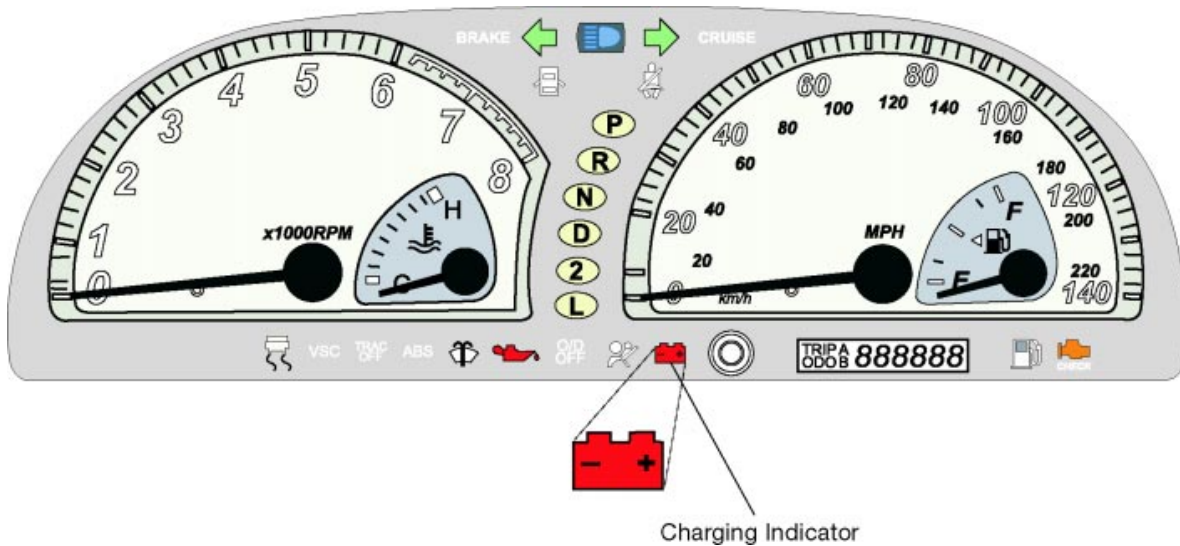

Fig. 5-19
TL623f519c

Alternator Output Test (No Load) Use the following steps to perform the test with a Sun VAT-40 or VAT-60 tester:

1. Set the tester's Load control to OFF.
2. Connect the tester leads.
 - Red lead to positive terminal.
 - Black lead to negative terminal.
 - Clamp the ammeter clamp-on probe onto the battery's ground cable.
3. Set the tester's voltage range to the appropriate setting.
4. Zero both meters on the tester, if needed.
5. Turn the ignition switch to ON (do not start the engine).

Alternator Output Test (No Load)

A VAT-40 Battery Tester is connected for the no load output test.

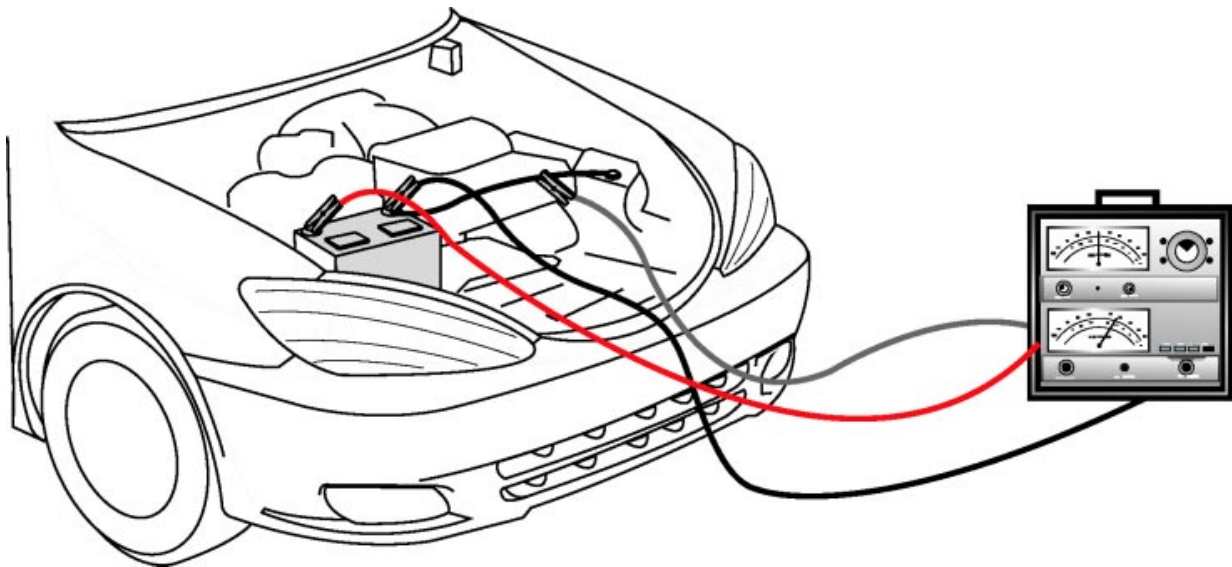

Fig. 5-20
TL623f520c

6. Record the ammeter reading.
 - This is the discharge current (typically about 6 amps).
 - Alternator must supply this amount of current before it can provide charging current to the battery.
7. Start the engine and adjust engine speed to about 2,000 RPM.
8. Allow engine to warm up for 3 to 4 minutes.
9. Record the ammeter reading.
 - Add the discharge current (from Step 4) to the reading now on the ammeter. The total should be less than 10 amps.
 - The battery may not have been fully charged if the total current is more than 10 amps. Monitor the ammeter; the reading should decrease as the battery charges.
10. Record the voltmeter reading.
 - The voltmeter reading should be within specification for the alternator during the entire test. This value is typically between 13 and 15 volts; refer to the appropriate service manual for the correct specification.
 - If the voltmeter reading is higher than specified, the voltage regulator is probably defective. Replace the regulator if possible or replace the alternator.
 - If the voltmeter reading is lower than specified, the cause could be a bad regulator or a fault in the alternator windings. Replace the alternator if it has an internal voltage regulator.
 - For alternators with externally mounted regulators, confirm the cause by grounding Terminal F on the alternator. This bypasses the regulator. If voltage increases, the voltage regulator is probably defective. If the voltage remains low, replace the alternator; there is a problem with the windings.
11. Remove ground from alternator Terminal F.

Alternator Output Test (With Load) Use the following steps to perform the test with a Sun VAT-40 or VAT-60 tester:

1. Keep the tester connections as for the alternator output test with no load.
2. Adjust engine speed to specified RPM (refer to the appropriate service manual).
3. Adjust the tester's load control to obtain the highest ammeter reading possible while keeping the voltage reading at or above 12 volts.
4. Record the highest ammeter reading.
 - The reading should be within 10% of the alternator's rated output.
 - Replace the alternator if the reading is more than 10% below the value specified.

Alternator Output Test (With Load)

This figure shows the location of the "F" terminal for various alternator types.

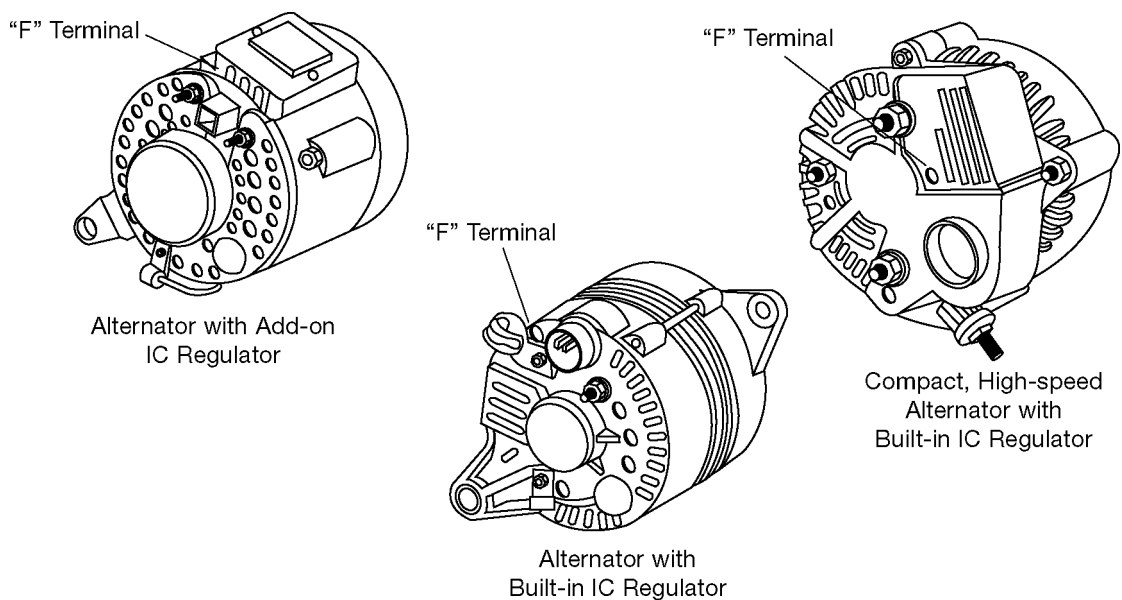

Note: Current model alternators do not have an "F" Terminal.

Fig. 5-21
TL623f521

Voltage Drop Test Voltage drop tests can isolate unwanted high resistance in the charging system. High resistance can cause these symptoms:

- Charging system cannot fully charge battery.
- Abnormally high current is drawn from battery under high load conditions.

Use a DMM to perform a voltage drop test on the positive side of the battery as follows:

1. Connect the red meter lead to Terminal B on the alternator.
2. Connect the black meter lead to the positive battery terminal.
3. Start the engine; adjust engine speed to 2,000 RPM.
4. Note the voltage reading.
 - The voltage drop should be less than 0.2 volts.
 - If the reading is higher, look for poor connections at the alternator and at the battery. Also, look for damaged wires or corroded wires.

Test for voltage drop on the ground side of the battery as follows:

5. Keep the engine running at 2,000 RPM.
6. Connect the red meter lead to the negative (ground) battery terminal.
7. Connect the black meter lead to the alternator frame.
8. Note the voltage reading.
 - The voltage drop should be less than 0.2 volts.
 - If the reading is higher, look for poor connections between the battery and ground and from the alternator frame to ground. Also, look for a damaged or corroded battery ground cable.

Voltage Drop Test

Voltage drop tests can isolate high resistance in the charging system. Test voltage drop on the positive and the ground side of the battery.

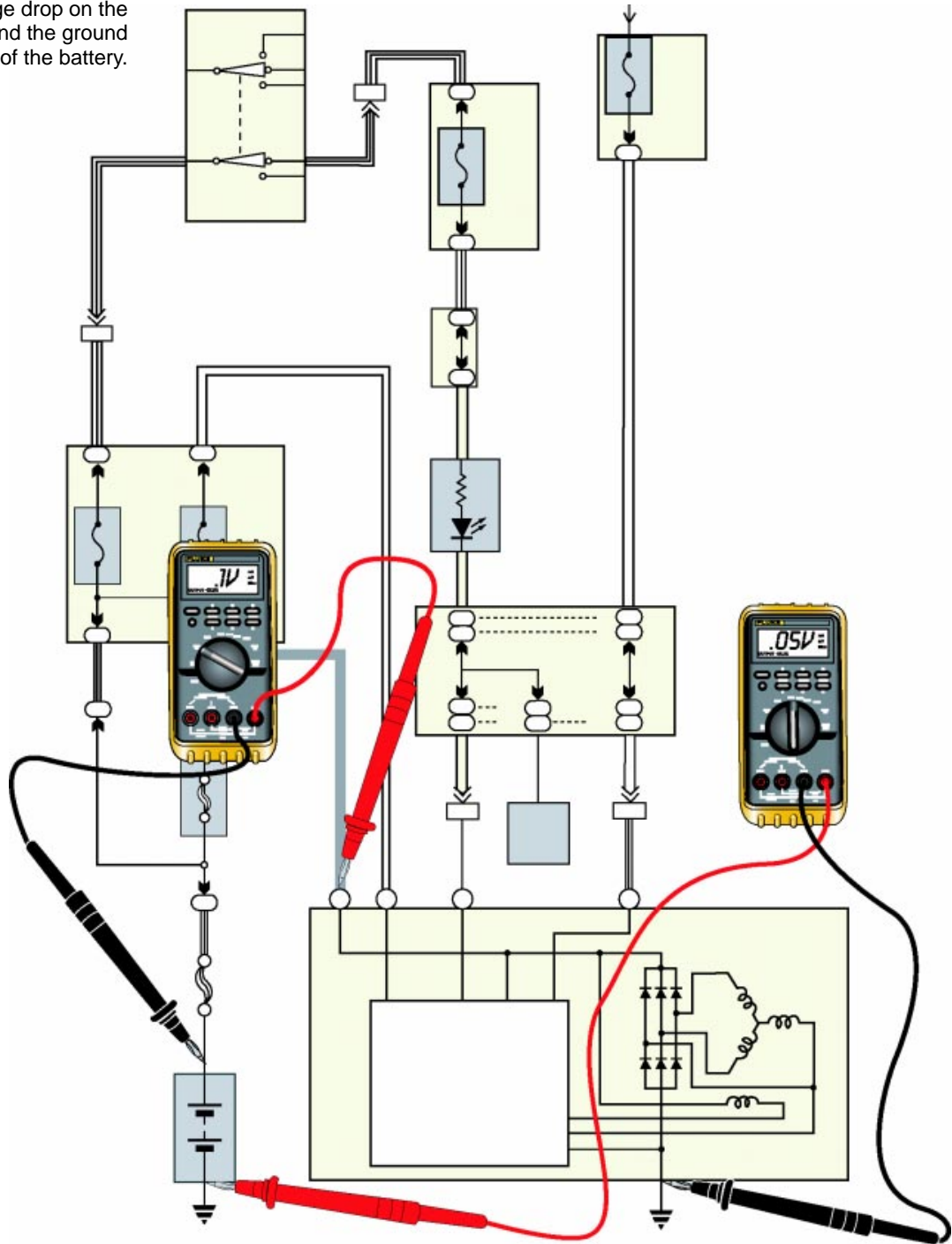

Fig. 5-22
TL623f522c



Notes



WORKSHEET 5-1

Charging System Components

Worksheet Objectives

When you have completed this worksheet, you will be able to identify and name the components that make up the charging system.

Tools and Equipment

For this exercise you will need the following:

- Technician's Handbook
- Highlighter or colored pen/pencil (red or pink for power, green for ground)
- EWD
- Repair Manual

Exercise 1: Identifying and Naming Components

Refer to the charging system diagram in Fig. 5W1-1. Match the numbers on the drawing to the correct component names below:

1. _____
2. _____
3. _____
4. _____
5. _____
6. _____
7. _____
8. _____

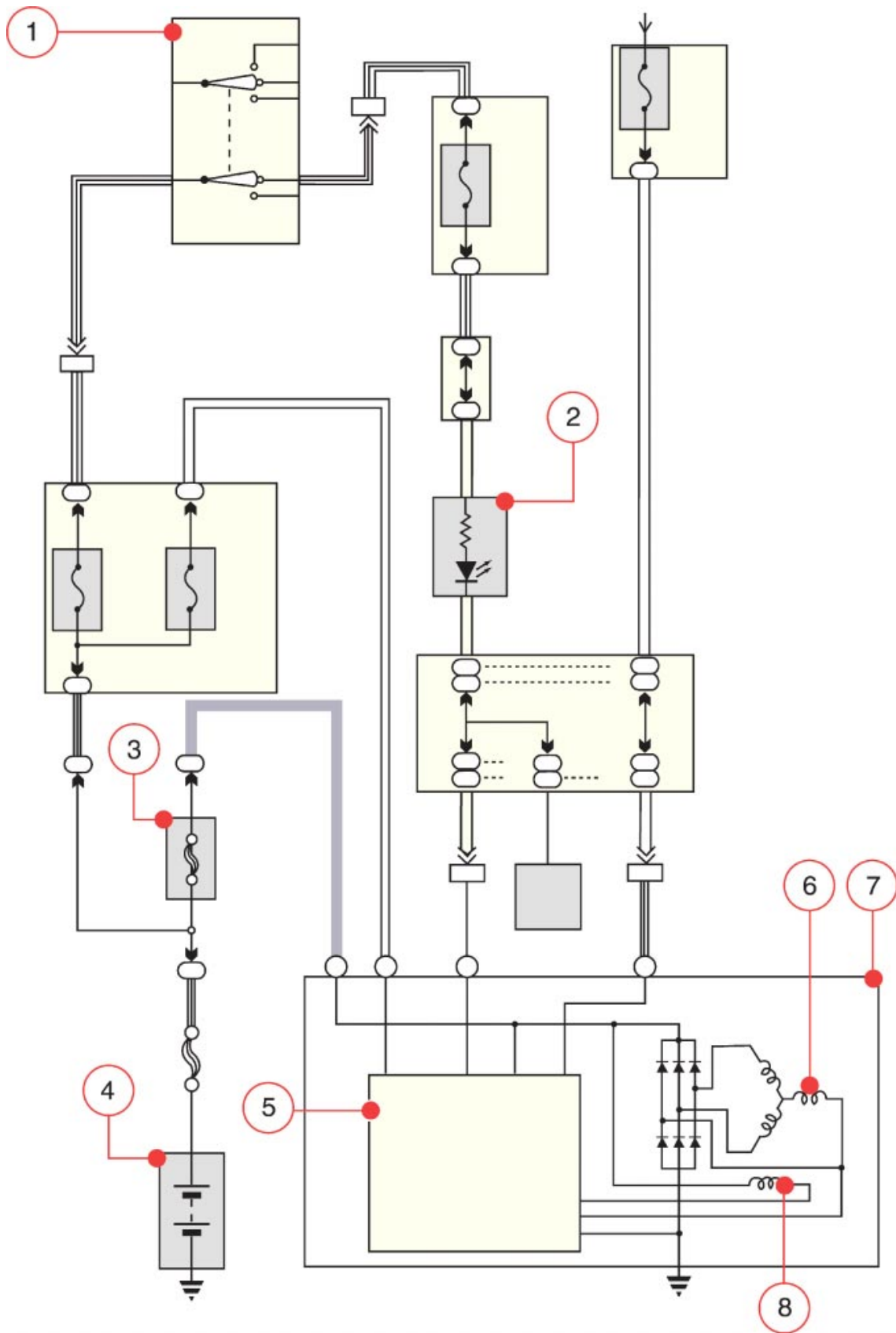

Fig. 5W1-1
TL623f001c-5W1

Exercise 2: Current Flow - Alternator Output Voltage Low

Refer to the charging system diagram in Fig. 5W1-2. Use a highlighter or colored pen (red or pink for power, green for ground) to trace current flow. Assume that the voltage regulator has detected alternator output voltage is low.

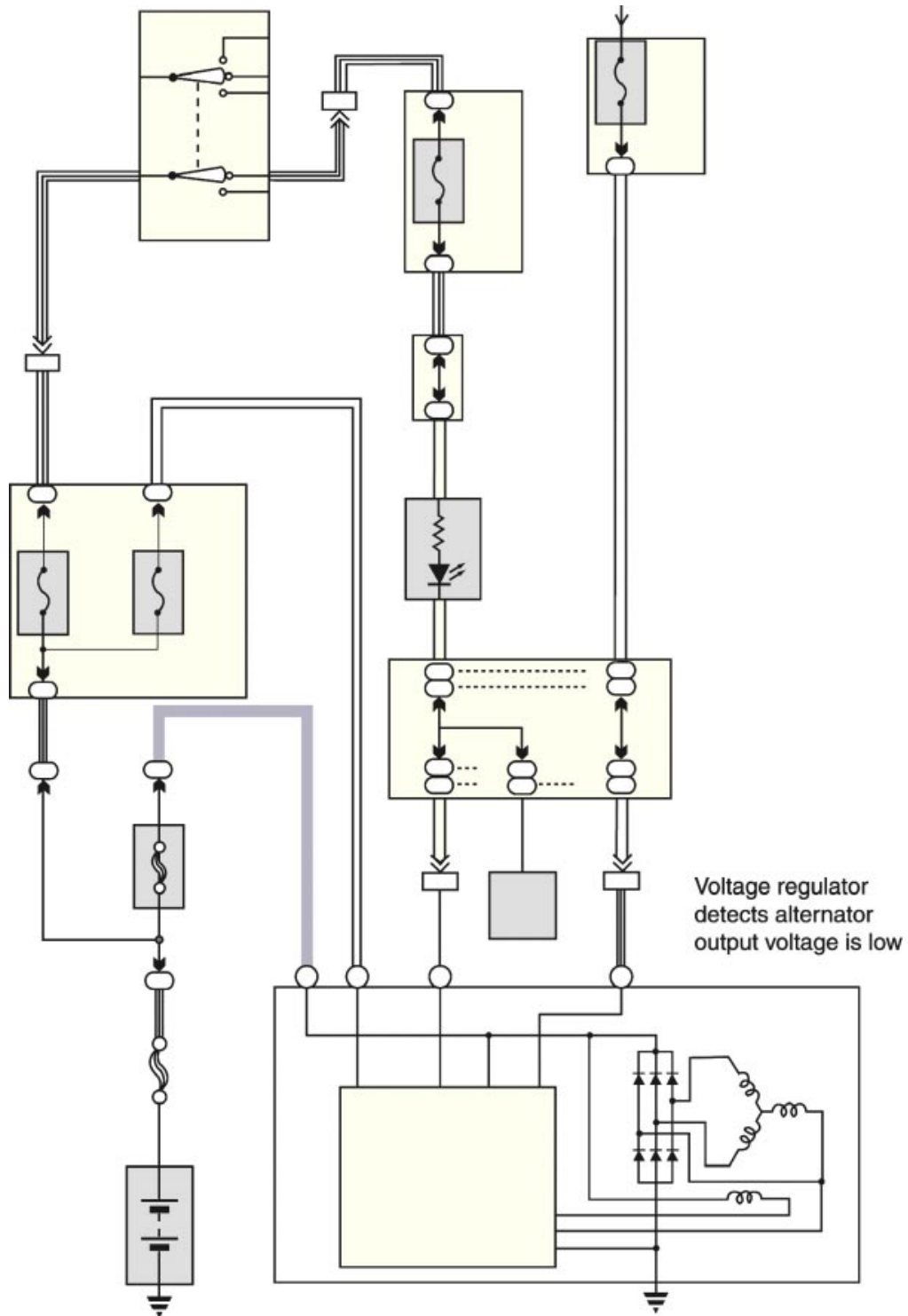

Fig. 5W1-2
TL623f002c-5W1

Exercise 3: Current Flow - Alternator Output Voltage High

Refer to the charging system diagram in Fig. 5W1-3. Use a highlighter or colored pen (red or pink for power, green for ground) to trace current flow. Assume that the voltage regulator has detected alternator output voltage is high.

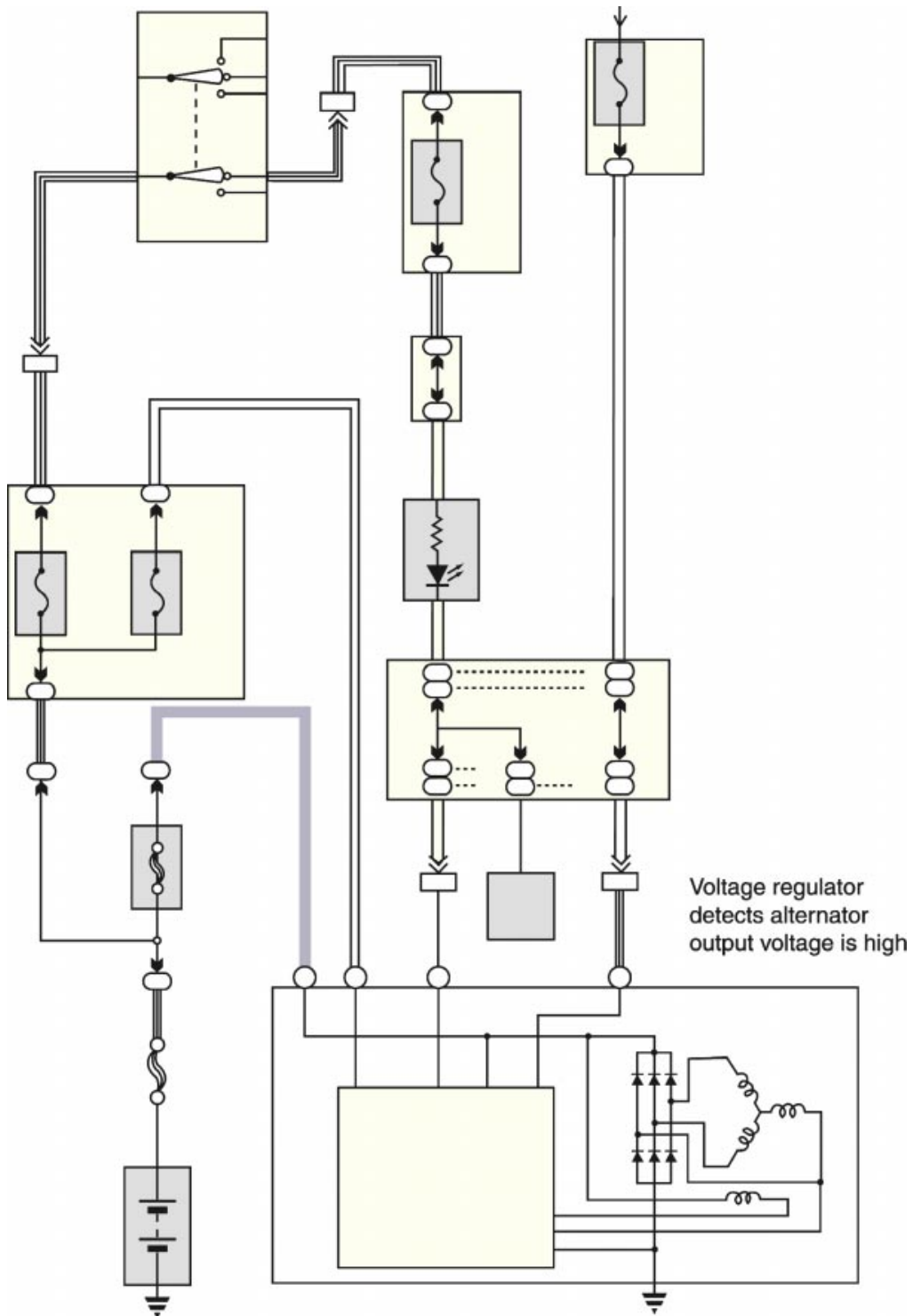

Fig. 5W1-3
TL623f003c-5W1

Charging System Components

Name: _____ Date: _____

Review this sheet as you are doing the Charging System Components worksheet. Check each category after viewing the instructor’s presentation and completing the worksheet. Ask the instructor if you have questions regarding the topics provided below. Additional space is provided under topic for you to list any other concerns that you would like you instructor to address. The comments section is provided for your personal comments, information, questions, etc.

I have questions

I know I can

Topic			Comment
Identify Components			
Trace Current Flow			



Notes



WORKSHEET 5-2
Charging System Visual Inspection

Vehicle	Year/Prod. Date	Engine	Transmission
---------	-----------------	--------	--------------

Worksheet Objectives

When you have completed this worksheet, you will be able to demonstrate a visual inspection of the charging system on an actual vehicle.

Tools and Equipment

For this exercise you will need the following:

- EWD
- Repair Manual
- Vehicle

Exercise 1: Visual Inspection

Caution - The battery contains sulfuric acid. Take precautions to avoid possible injury or damage to the vehicle:

- Remove rings, wristwatch, and any jewelry.
- Wear safety glasses and protective clothing.

Inspect each component on the list below. Describe the condition of each item you inspected in the table below:

Inspection Item	Condition
Battery	
Fuses, fusible links	
Alternator drive belt	
Alternator wiring	
Alternator noise level	
Charging indicator	

Charging System Visual Inspection

Name: _____ Date: _____

Review this sheet as you are doing the Charging System Visual Inspection worksheet. Check each category after viewing the instructor's presentation and completing the worksheet. Ask the instructor if you have questions regarding the topics provided below. Additional space is provided under topic for you to list any other concerns that you would like your instructor to address. The comments section is provided for your personal comments, information, questions, etc.

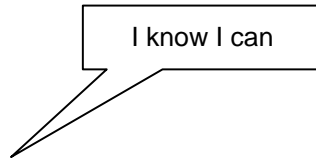
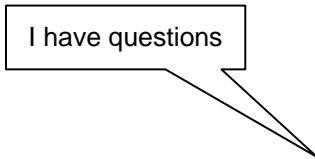

Topic	Comment		
Visual Inspection			



WORKSHEET 5-3
Alternator Output Tests

Vehicle	Year/Prod. Date	Engine	Transmission
---------	-----------------	--------	--------------

Worksheet Objectives

In this worksheet, you will practice performing alternator output tests. When you have completed this module, you should be able to use a VAT-40 or VAT-60 tester to determine if an alternator is operating correctly.

Tools and Equipment

For this exercise you will need the following:

- EWD
- Repair Manual or TIS machine
- Vehicle
- VAT-40 or VAT-60 tester

Exercise 1: Alternator Output Test - No Load

Use the following steps to perform the test with a Sun VAT-40 or VAT-60 tester:

1. Set the tester's Load control to OFF.
2. Connect the tester leads.
 - Red lead to positive terminal
 - Black lead to negative terminal
 - Clamp the ammeter clamp-on probe onto the battery's ground cable.
3. Set the tester's voltage range to the appropriate setting.
 - Set "Test Selection" to position 2 "Charging"
4. Zero both meters on the tester, if needed.
5. Turn the ignition switch to ON (do not start the engine).
6. Record the ammeter reading here: _____ amps
7. Start the engine and adjust engine speed to about 2,000 RPM.
8. Allow engine to warm up for 3 to 4 minutes, and then proceed to the next page.
9. Record the ammeter reading here: _____ amps.

10. Add the discharge current (from Step 6) to the reading now on the ammeter. Record the total here: _____ amps.

Is the total more than 10 amps? ___ Yes ___ No

Note - If the total current is more than 10 amps, the battery may not have been fully charged. Continue to monitor the ammeter; the reading should decrease as the battery charges.

11. Record the voltmeter reading here: _____ volts

Is the reading within specification for this vehicle? ___ Yes ___ No

12. Keep the tester set up for the next exercise.

Exercise 2: Alternator Output Test - With Load

Adjust engine speed to specified RPM (refer to the appropriate service manual).

Adjust the tester's load control to obtain the highest ammeter reading possible while keeping the voltage reading at or above 12 volts.

Record the highest ammeter reading.

Is the reading within specification for this vehicle? ___ Yes ___ No

What should you do if the reading is more than 10% below the specification for this vehicle?

Alternator Output Tests

Name: _____ Date: _____

Review this sheet as you are doing the Alternator Output Tests worksheet. Check each category after viewing the instructor’s presentation and completing the worksheet. Ask the instructor if you have questions regarding the topics provided below. Additional space is provided under topic for you to list any other concerns that you would like your instructor to address. The comments section is provided for your personal comments, information, questions, etc.

I have questions

I know I can

Topic			Comment
Output Test - No Load			
Output Test - With Load			



Notes



WORKSHEET 5-4 *Charging System Voltage Drop Tests*

Vehicle	Year/Prod. Date	Engine	Transmission
---------	-----------------	--------	--------------

Worksheet Objectives

In this worksheet, you will practice performing voltage drop tests in the charging system. When you have completed this module, you should be able to test the positive and negative sides of the charging circuit for voltage drops.

Tools and Equipment

For this exercise you will need the following:

- EWD
- Repair Manual
- Vehicle
- Digital multimeter (DMM)

Exercise 1: Voltage Drop on the Positive Side of the Battery

1. Connect the red meter lead to Terminal B on the alternator.
2. Connect the black meter lead to the positive battery terminal.
3. Start the engine; adjust engine speed to 2,000 RPM.
4. Record the voltage reading here: _____ volts.
5. Is the voltage drop less than 0.2 volts? ____ Yes ____ No

What should you look for if the reading is higher?

Exercise 2: Voltage Drop on the Negative Side of the Battery

6. Keep the engine running at 2,000 RPM.
7. Connect the red meter lead to the negative (ground) battery terminal.
8. Connect the black meter lead to the alternator frame.
9. Record the voltage reading here: _____ volts.
10. Is the voltage drop less than 0.2 volts? ____ Yes ____ No
11. What should you look for if the reading is higher?

Charging System Voltage Drop Tests

Name: _____ Date: _____

Review this sheet as you are doing the Charging System Voltage Drop Tests worksheet. Check each category after viewing the instructor's presentation and completing the worksheet. Ask the instructor if you have questions regarding the topics provided below. Additional space is provided under topic for you to list any other concerns that you would like your instructor to address. The comments section is provided for your personal comments, information, questions, etc.

I have questions

I know I can

Topic			Comment
Voltage Drop Test			



Notes

Introduction to Electronic Signals

Oscilloscope

An oscilloscope displays voltage changes over time. Use an oscilloscope to view analog and digital signals when required during circuit diagnosis.

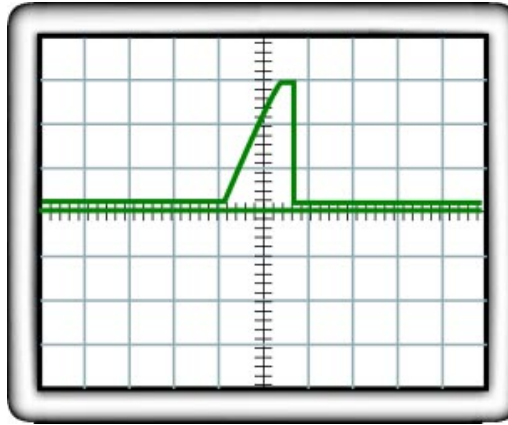

Fig. 6-01
TL623f600c

Input and Output Signals

An understanding of digital and analog signals will help you choose appropriate test equipment and troubleshoot effectively. Automotive circuits use two types of signals:

- INPUT - provides information about operating conditions (switches, sensors)
- OUTPUT - causes an electrical or electronic device to operate (lamps, LEDs, relays, motors)

Input and output signals can be either digital or analog, depending on the application. Electronic Control Units (ECUs) typically receive, process, and generate both analog and digital signals.

Analog Signals A signal that represents a continuously variable voltage is an analog signal.

Variable resistors - A throttle position sensor incorporates a continuously variable resistor to generate an analog signal.

- Variable resistor changes the sensor's internal resistance with the position of the throttle.
- The voltage produced by the sensor is also continuously variable; it is an analog signal.
- The signal can be any value from 0 through battery voltage.

A fuel gauge sender is another device that uses variable resistance to send an analog signal.

Oscilloscope Display of Analog and Digital Signals

Input and output signals can be either analog or digital.

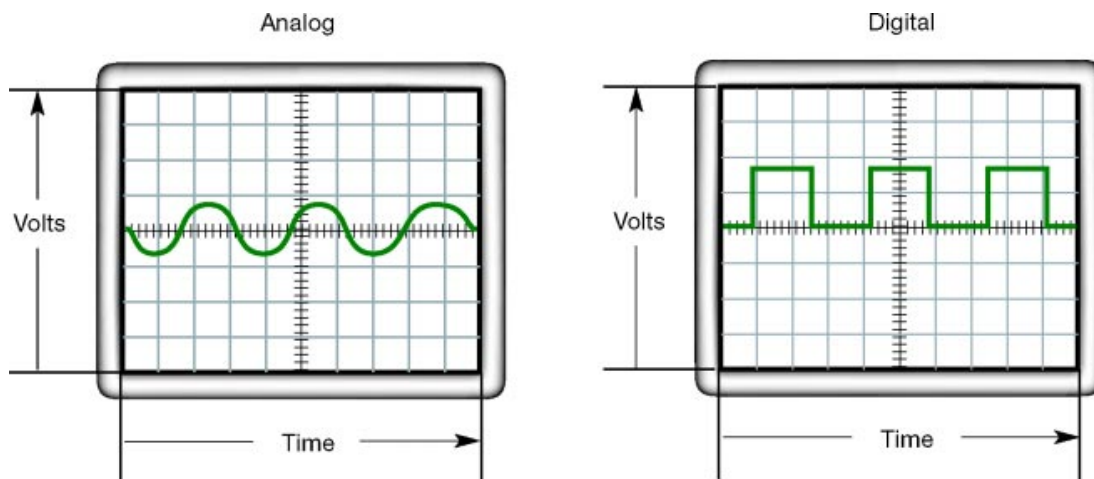

Fig. 6-02
TL623f602c

Temperature and position sensors - These sensors vary internal resistance in response to temperature or position. The signal is a varying voltage analog type.

Analog Signals

This sensor is a variable resistor that generates an analog signal.

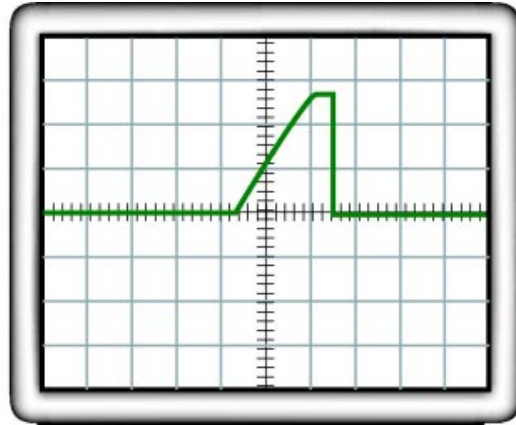
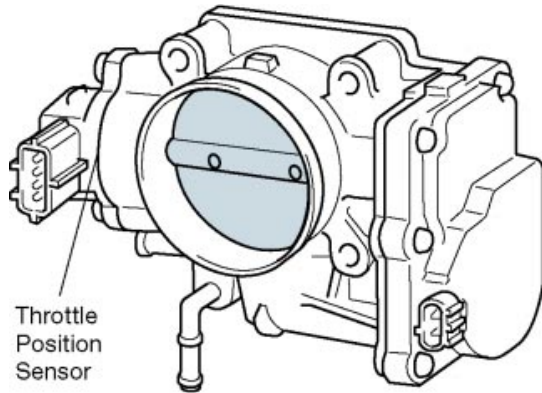

Fig. 6-03
TL623f603c

Digital Signals A signal that represents just two voltage levels is a digital signal. A digital signal has only two states. The signal is not continuously variable. The two states can be expressed in various ways:

- High/Low
- ON/OFF
- 1/0

In a typical automotive electronic circuit, a digital signal is either 0 volts or + 5 volts.

Example 1 - A switch is a simple device that generates a digital signal:

- Switch open = 0 volts (also Low or OFF)
- Switch closed = 5 volts (also High or ON)

Electronic Control Units - ECUs can derive or provide information through these characteristics of a digital signal:

- Signal state (ON or OFF)
- Signal frequency (how many times per second the signal state change from high to low)
- Signal duration (how long a signal stays ON or OFF)
- Duty cycle (the percentage of time ON versus time OFF)

Digital Signal **- Power Steering** **Pressure Switch**

A switch is an example of a digital signal producing device. The output is either on or off and produces either a high or low voltage.

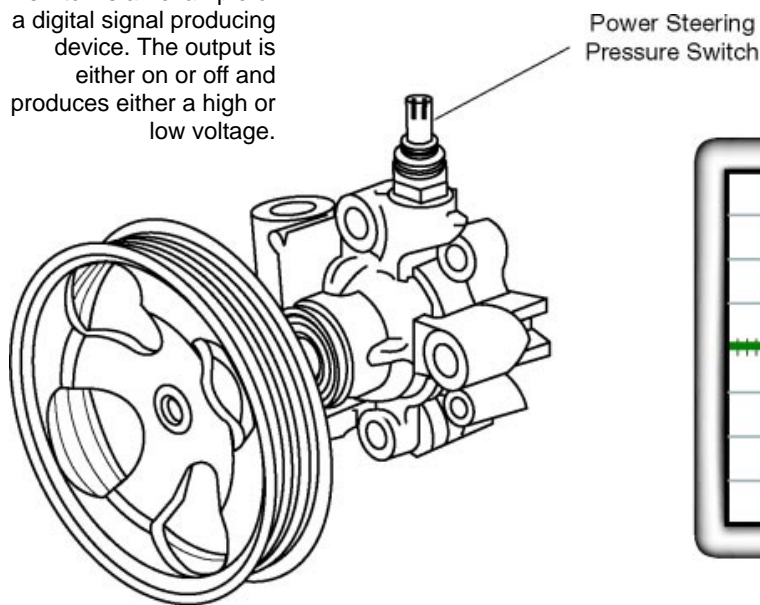

Fig. 6-04
TL623f604c

Electronic Control Units Electronic Control Units monitor inputs, process input signals, and generate output signals.

Inputs - Switches and sensors send input signals to ECUs.

- These signals tell the ECU what is happening in the systems it is controlling.
- Input signals provide the ECU with information about operating conditions and driver commands.

Outputs - ECUs are used to control various systems in the vehicle:

- Engine
- Automatic transmission
- Climate control
- Cruise control
- Anti-lock braking, traction control, and VSC
- Accessory systems

One type of ECU is an Engine Control Module (ECM). A typical ECM has these input signals:

- Water temperature
- Air/fuel ratio (oxygen sensor)
- Crankshaft position
- Camshaft position
- Throttle position
- Mass air flow

An ECM processes the information from the sensors and generates output commands to devices and systems that control engine operation:

- Ignition
- Fuel

Engine Control System

An ECM processes information from sensors and generates output commands to control engine operation.

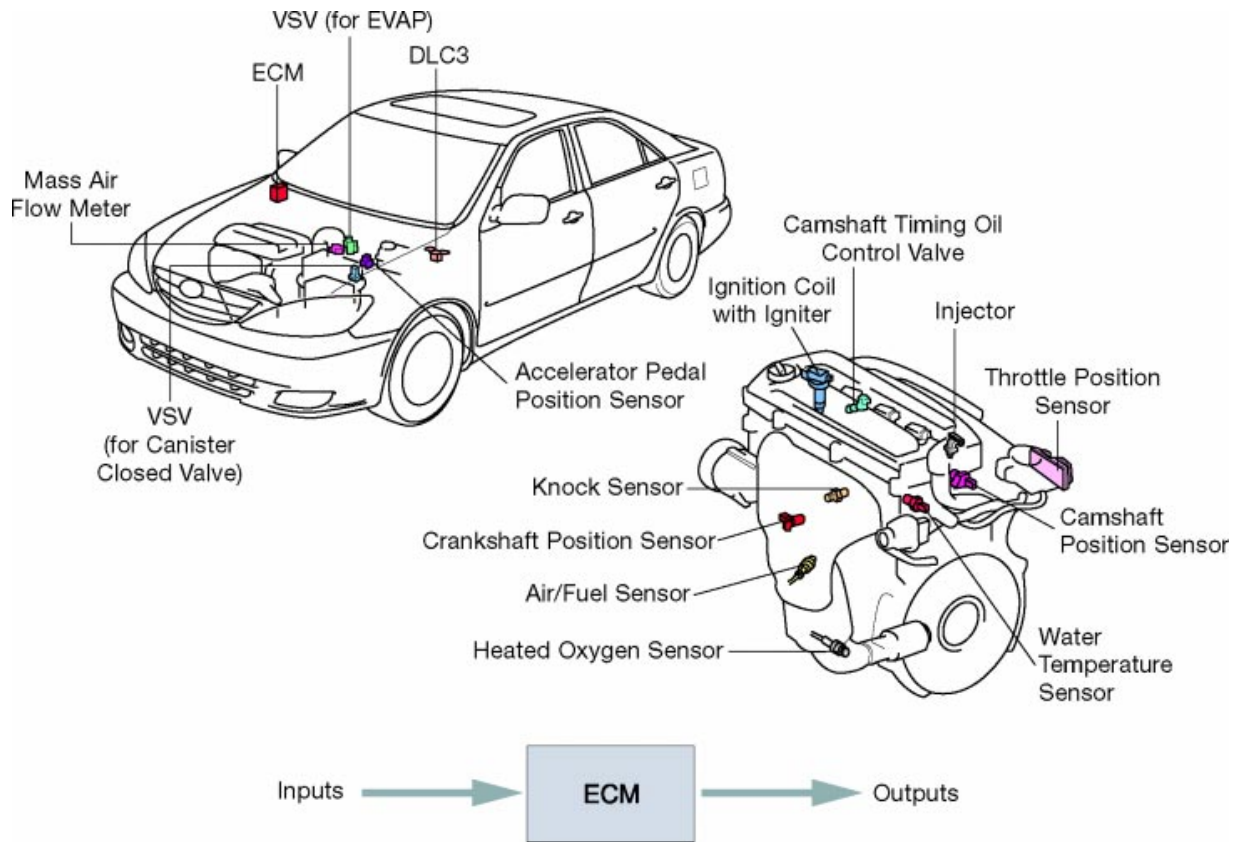
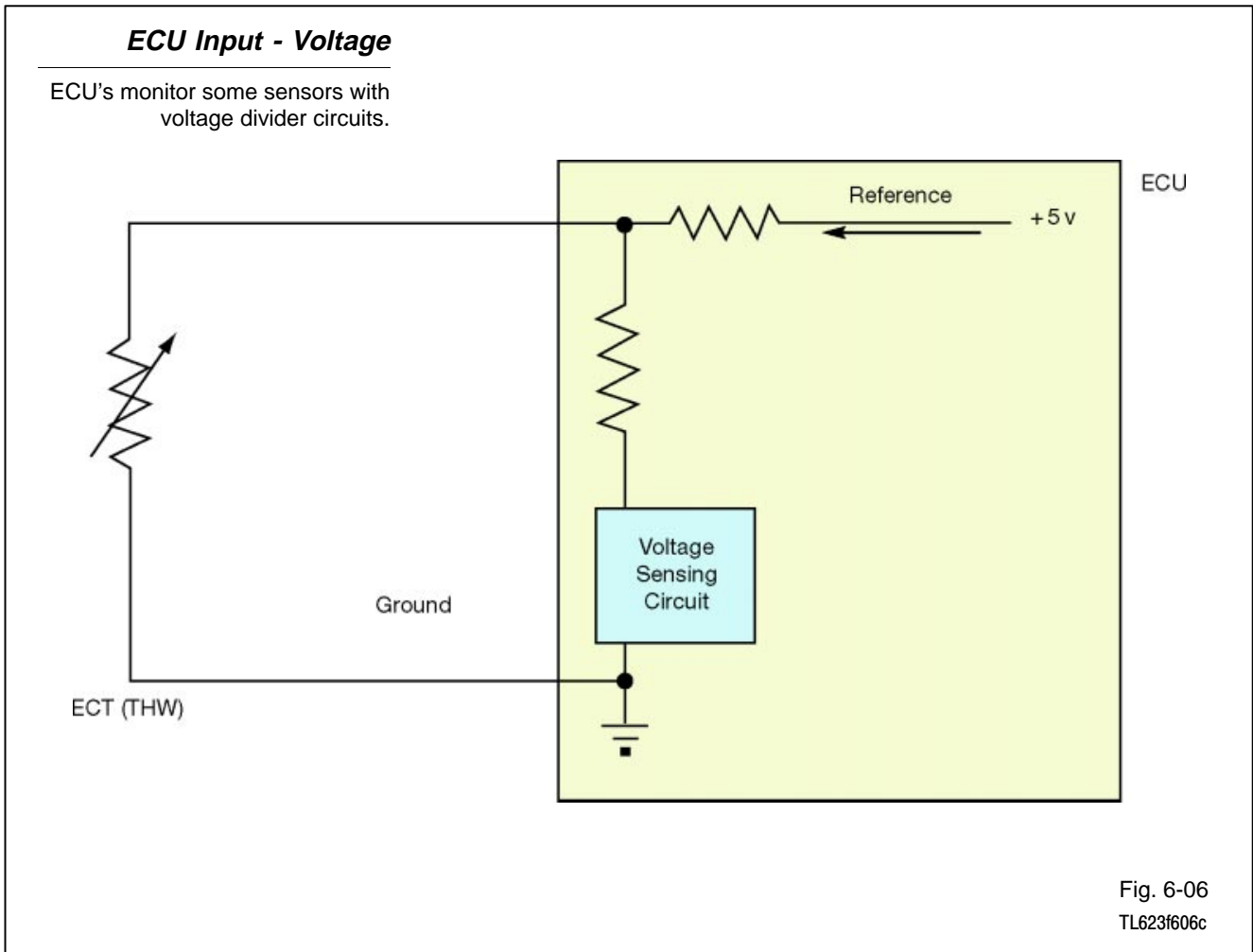

Fig. 6-05
TL623f605c

ECU Input - Voltage Divider Divider Electronic Control Units monitor some sensors using a voltage divider circuit.

A voltage divider circuit is typically used to generate a voltage that is different from the supply (battery) voltage.



ECU Data Processing How an Electronic Control Unit processes an input depends on the signal type.

Digital signals - Digital signals are in a form that ECUs can process directly.

Analog signals - ECUs typically convert an analog signal to a digital signal before processing the information. For example, an analog wheel speed sensor signal is converted to ON and OFF pulses for processing by the ABS ECU.

Look-up tables - ECUs process most input signals using look-up tables. A look-up table is a set of instructions, one for each possible condition the ECU may see. For example, if an ECM senses 200°F coolant temperature, the instruction in the look-up table may tell it to turn on the cooling fan. For 125°F coolant temperature, the instruction may be to turn off the cooling fan.

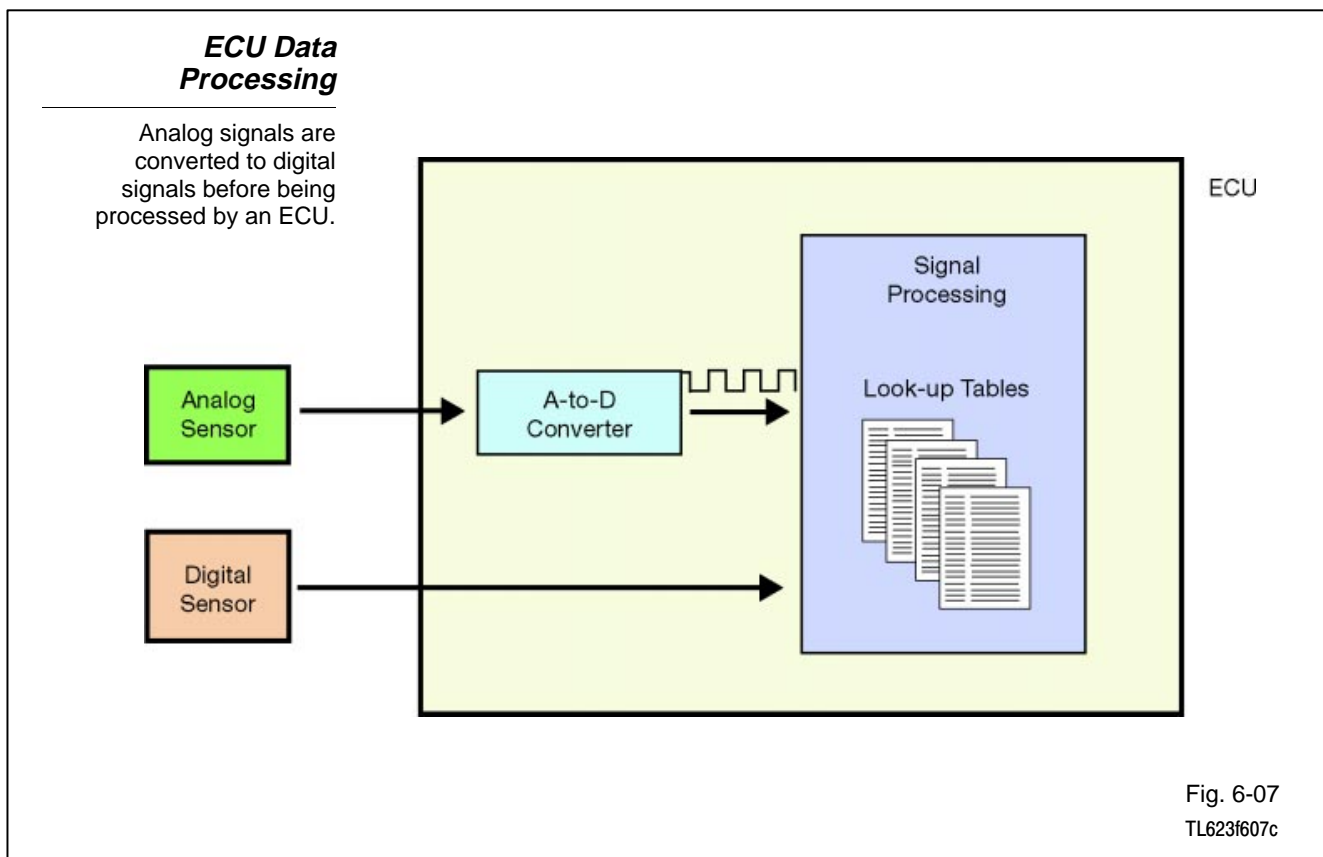

ECU Output Signals

ECUs operate a variety of output devices including:

- Door lock actuators
- Actuators to operate air redirection doors in climate control systems
- Indicator lamps (Check Engine, etc.)
- Ignition coil(s)

ECU Output Signals

After processing input signals, ECU's output commands to various actuator devices.

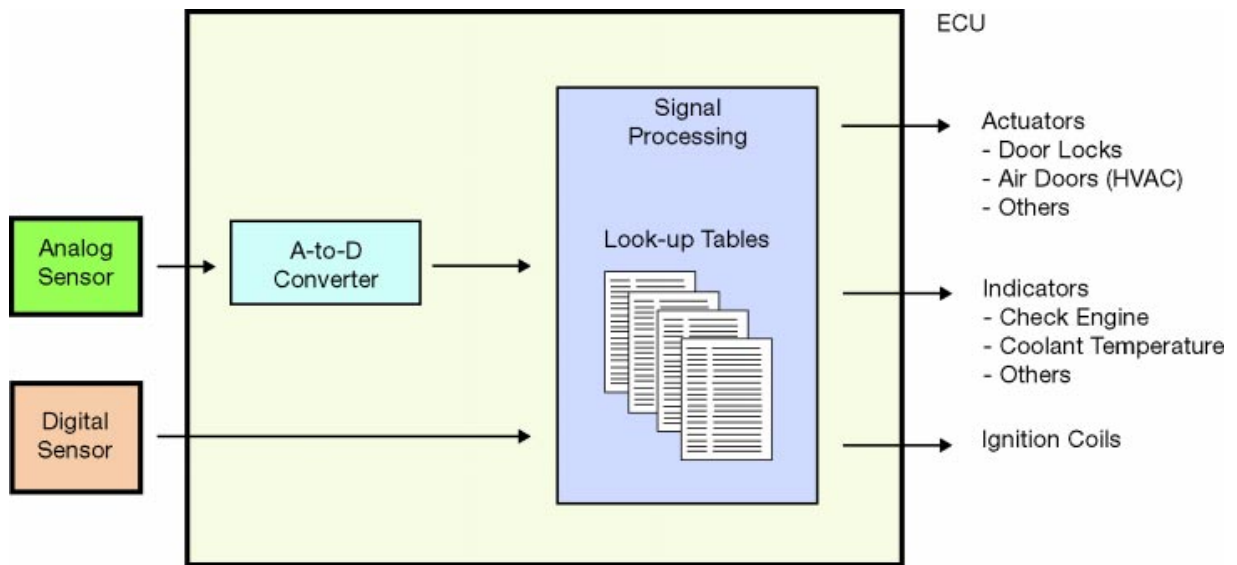

Fig. 6-08
TL623f608c

Troubleshooting with an Oscilloscope

Troubleshooting electronic control units consists of confirming three elements:

- Input device (sensor, switch) produces the required signals at the time they are needed;
- ECU processes input signals and produces the required output signals at the time they are needed;
- Output device responds to ECU's signals and operates correctly.

An oscilloscope, also called a “scope,” constructs a visual image of an electronic signal. This image takes the form of a graph. Like any graph, an oscilloscope image shows two values:

- **ON THE HORIZONTAL AXIS** - The scope shows the passage of time along the horizontal axis (moving from left to right). The units of time are set by a control on the oscilloscope.
- **ON THE VERTICAL AXIS** - The image on the scope display shows voltage along the vertical axis. The higher the signal is from the bottom of the graph, the higher is the voltage being represented.

Oscilloscope Display

An oscilloscope displays a visual representation of an electronic signal.

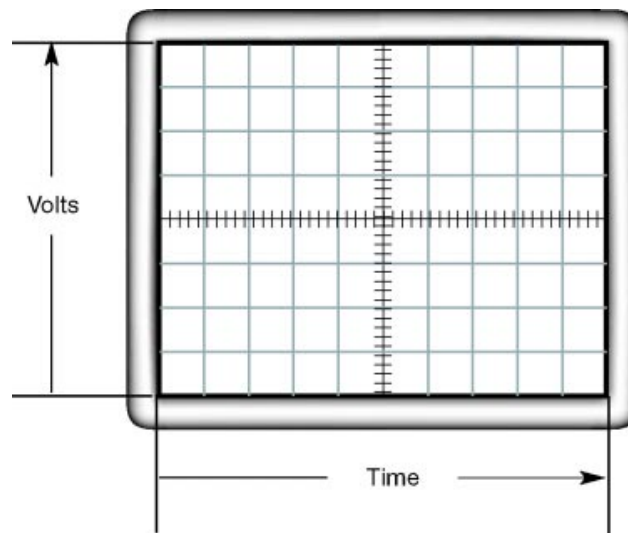

Fig. 6-09
TL623f609

An oscilloscope display provides a record of voltage over time.

Example 1 - Connect the oscilloscope leads to an automotive battery:

- Scope displays a constant horizontal line at about 12.6 volts.
- The horizontal line is constant because the voltage is not changing over time.

***Oscilloscope
Display - Battery
Voltage***

This is what battery voltage looks like on an oscilloscope display.

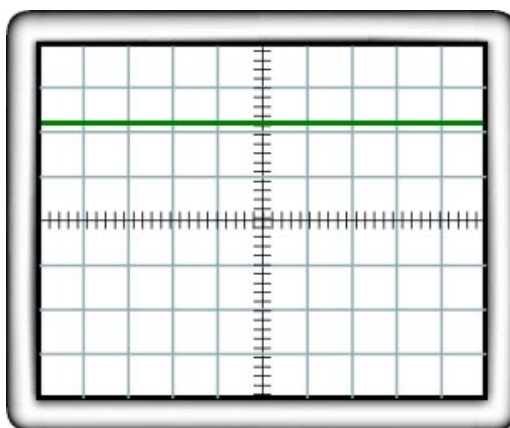

Fig. 6-10
TL623f610c

An oscilloscope display provides a record of voltage over time.

Example 2 - Connect the oscilloscope to the output of a throttle position sensor:

- Hold the throttle stationary, and the scope displays a constant horizontal line (voltage unchanging over time).
- Move the throttle from fully closed to fully open, and the scope displays a sloping horizontal line (voltage increases over time).

***Oscilloscope
Display - TPS
Signal***

This is a TPS signal on an oscilloscope display.

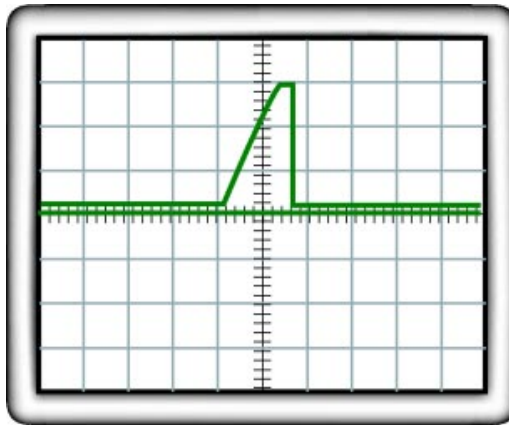

Fig. 6-11
TL623f600c

An oscilloscope display provides a record of voltage over time.

Example 3 - Connect the oscilloscope to the ground side of the cylinder # 1 fuel injector:

- Source voltage is supplied to the injector when the ignition is ON.
- The ECM controls the ground side of the circuit.
- The ECM varies the injector ON time to adjust the amount of fuel delivery.
- The ON time is viewed as the duration of time when there is 0 volts on the ground.
- The duration will vary as injector ON time changes due to fuel requirements of the engine.
- You can adjust the time setting on the scope to represent this value in a scale that is best for interpretation.

Digital signal characteristics - An oscilloscope display can represent all the characteristics of a digital signal:

- Voltage
- Frequency and pulse width (time)
- Duty cycle (time ON versus time OFF)

***Oscilloscope
Display
- Fuel Injector
Signal***

This is the signal from a fuel injector.

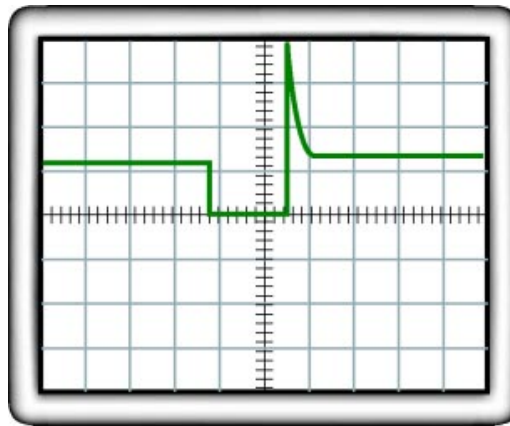

Fig. 6-12
TL623f612c



Notes



WORKSHEET 6-1
Analog and Digital Signals

Worksheet Objectives

When you have completed this worksheet, you will be able to:

- Distinguish between analog and digital signals
- Describe the applications of input and output signals in automotive circuits
- List the characteristics of analog and digital signals

Tools and Equipment

For this exercise you will need the following:

- Technician's Handbook
- EWD

Exercise 1: Input and Output Signals

Complete the following statements by filling in the blanks:

1. _____ signals provide information about operating conditions.
2. _____ signals cause an electrical or electronic device to operate.
3. Electronic control units (ECUs) typically receive both _____ signals and _____ signals.
4. An analog signal is a continuously variable _____.
5. A throttle position sensor is a _____ resistor and produces an _____ signal.
6. In a typical automotive electronic circuit, a digital signal is either _____ or _____.

Exercise 2: Signal Characteristics

List the characteristics of a digital signal that can be used to convey information:

1. _____
2. _____
3. _____
4. _____

List four sensors in the engine control system:

1. _____
2. _____
3. _____
4. _____

List four devices controlled by output signals from an ECU:

1. _____
2. _____
3. _____
4. _____

Exercise 3: Oscilloscopes

Complete the following statements by filling in the blank spaces.

1. An oscilloscope shows _____ on the horizontal axis.
2. An oscilloscope shows _____ on the vertical axis.
3. An oscilloscope display provides a record of _____ over time.

Analog and Digital Signals

Name: _____ Date: _____

Review this sheet as you are doing the Analog and Digital Signals worksheet. Check each category after viewing the instructor’s presentation and completing the worksheet. Ask the instructor if you have questions regarding the topics provided below. Additional space is provided under topic for you to list any other concerns that you would like you instructor to address. The comments section is provided for your personal comments, information, questions, etc.

I have questions

I know I can













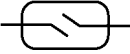

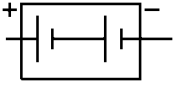
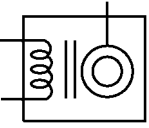



Topic	Comment		
Distinguish between Input and Output Signals			
Digital and Analog Signals			
Signal Characteristics			
Oscilloscopes			





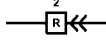



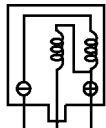

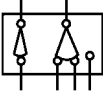

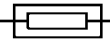

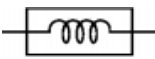
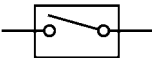

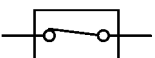
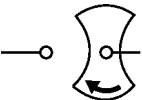
Notes

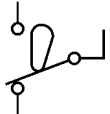
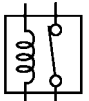
Appendix A

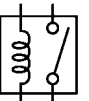
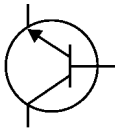
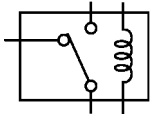
Toyota Wiring Diagram Symbols

	<p>ANALOG METER Current flow activates a magnetic coil which causes a needle to move, thereby providing a relative display against a background calibration.</p>		<p>DIODE A semiconductor which allows current flow in only one direction.</p>
	<p>ANALOG SPEED SENSOR Uses magnetic impulses to open and close a switch to create a signal for activation of other components.</p>		<p>DIODE, ZENER A diode which allows current flow in one direction but blocks reverse flow only up to a specific voltage. Above that potential, it passes the excess voltage. This acts as a simple voltage regulator.</p>
	<p>BATTERY Stores and converts chemical energy into electrical energy. Provides DC current for the auto's various electrical circuits.</p>		<p>DISTRIBUTOR (I.I.A.) Channels high-voltage current from the ignition coil to the individual spark plugs.</p>
	<p>BIMETALLIC THERMOSWITCH An automatic switch which opens or closes, depending on temperature.</p>		<p>DOUBLE-THROW SWITCH A switch which continuously passes current through one set of contacts or the other.</p>
	<p>CAPACITOR (Condenser) A small holding unit for temporary storage of electrical current. Capacitors with a ground connection are frequently called Condensers.</p>		<p>FUSE A thin metal strip which burns through when too much current flows through it, thereby stopping current flow and protecting a circuit from damage.</p>
	<p>CIGARETTE LIGHTER An electric resistance heating element.</p>		<p>FUSIBLE LINK A heavy-gauge wire placed in high amperage circuits which burns through on overloads, thereby protecting the circuit.</p>
	<p>CIRCUIT BREAKER Basically a reusable fuse, a circuit breaker will heat and open if too much current flows through it. Some units automatically reset when cool, others must be manually reset.</p>		<p>GROUND The point at which wiring attaches to the chassis, thereby providing a return path for an electrical circuit; without a ground, current cannot flow.</p>
	<p>CONNECTORS Male connectors typically have extended pins which engage sockets in the female connector. Toyota wiring diagrams show harness connectors from the open end.</p>	<p>Single Filament</p> 	<p>HEADLAMPS Current flow causes a headlamp filament to heat up and cast light. A headlamp may have either a single filament or a double filament.</p>
 Female Side Male Side	<p>CONNECTOR, HARNESS TO HARNESS A connector in the wiring harness which joins two harness sections. This symbol refers to pin 2 of connector R.</p>	<p>Double Filament</p> 	
	<p>CONNECTOR, TO JUNCTION BOX A connection of a wire harness to a junction block. This symbol refers to pin 6 of connector C at junction block 1.</p>		<p>HORN An electric device which sounds a loud audible signal.</p>
	<p>DIGITAL METER Current flow activates one or many LED's, LCD's or fluorescent displays, which provide a relative or digital display.</p>		<p>IGNITION COIL Converts low-voltage DC current into high-voltage ignition current for firing the spark plugs.</p>

	<p>IGNITION SWITCH A key operated switch with several positions which allow various circuits to become operational, including the primary ignition circuit.</p>		<p>SENSOR (Thermistor) A resistor which varies its resistance with temperature.</p>
	<p>LAMP Current flow through a filament causes a lamp to heat up and cast light.</p>		<p>SHORT PIN Used to provide an unbroken connection within a junction block.</p>
	<p>LED (LIGHT EMITTING DIODE) Upon current flow, these diodes cast light without emitting the heat of a comparable lamp. Used in instrument displays.</p>		<p>SOLENOID An electromagnetic coil which creates its own mechanical movement or force upon current flow.</p>
<p>Normally Open</p> 	<p>MANUAL SWITCH Opens and closes circuits, thereby stopping or allowing current flow.</p>		<p>SPEAKER An electromechanical device which creates sound waves from current flow.</p>
<p>Normally Closed</p> 			<p>SWITCH, WASHER TIMER SWITCH Controls the intermittent operation of the windshield washer jets.</p>
	<p>MOTOR A power unit which converts electrical energy into mechanical energy or rotary motion.</p>		<p>SWITCH, WIPER PARK Automatically returns wipers to the stop position when the wiper switch is turned off.</p>
<p>Normally Closed</p> 	<p>RELAY Basically, an electrically operated switch which may be normally closed or normally open. Current flow through a small coil creates a magnetic field which either opens or closes an attached switch.</p>		<p>TAPPED RESISTOR A resistor which supplies two or more different non-adjustable resistance values.</p>
<p>Normally Open</p> 			<p>TRANSISTOR A solid-state device typically used as an electronic relay; stops or passes current depending on the applied voltage at "base."</p>
	<p>RELAY DOUBLE THROW A relay which passes current through one set of contacts or the other.</p>	<p>Not Connected</p> 	<p>WIRES Wires are always drawn as straight lines on wiring diagrams. Crossed wires, without a black dot at the junction, are not joined; crossed wires with a black dot at the junction, are spliced (joined) connections.</p>
	<p>RESISTOR An electrical component with a fixed resistance, placed in a circuit to reduce voltage to a specific value.</p>	<p>Spliced</p> 	
	<p>RESISTOR, VARIABLE or RHEOSTAT A controllable resistor with a variable rate of resistance. Also called a potentiometer or rheostat.</p>		

Glossary of Terms

A

A - Abbreviation for ampere, the unit of measurement of current.

Active Materials - The metals and acids used in a storage battery which cause a chemical reaction to occur and voltage potential to be developed.

Afterglow - The time the glow plugs remain activated after fuel in a diesel engine starts to self-ignite. The added heat is used to reduce white smoke and improve slow idle.

Alternating Current (AC) - An electric current whose polarity is constantly cycling between positive and negative. (Reverse direction or flow at regular intervals.)

Alternator - A type of generator used in automobiles to produce electric current. Its A.C. (Alternating Current) output is internally rectified (changed) to D.C. (Direct Current) through the use of diodes.

Ammeter - An electrical meter used to measure the amount of current flowing in a circuit. It reads amperes of current flow. The ammeter must be connected in series with the circuit ... red lead toward the voltage source, black lead toward ground.

Amperage - The amount of current (amperes) flowing in a circuit.

Ampere - The unit of measure for the flow of electrons, or current, in a circuit. The amount of current produced by one volt acting against one ohm of resistance.

Ampere Hour - Unit used to rate batteries. The quantity of electricity delivered by a current of one ampere flowing for one hour.

Ampere-Hour Rating - A battery rating based on the amperes of current that a battery can supply steadily for 20 hours, with no battery cell falling below 1.75 volts. Also called a 20-hour discharge rating.

Ampere Turn - The amount of magnetism or magnetizing force produced by a current of one ampere flowing around a coil of one turn. The product of the current flowing through a coil multiplied by the number of turns or loops of wire in a coil.

Analog - Method of transmitting information through an electrical circuit by regulating or changing the current or voltage.

Anode - Positive terminal or electrode through which current flows in a semiconductor.

Armature - Conductor or coil of wire moved through a magnetic field to produce current. In an alternator, the rotor is a magnetic field that rotates inside the stator coils to induce voltage in them. In a motor, it is the rotating electromagnetic field interacting with the stationary magnets to produce a turning motion.

B

Armature Circuit Tests - Tests used to determine if there are any short circuits or opens and grounds in the armature of a starter motor.

Atom - The small particles which make up all matter. An atom is made up of a positive-charged nucleus with negative-charged electrons orbiting around it.

Ballast (Primary) Resistor - A resistor in the primary circuit that stabilizes ignition system voltage and current flow.

Bar Magnet - A straight permanent magnet.

Base - The center layer of semiconductor material in a transistor.

Battery - A group of two or more cells of a lead-acid (storage) battery connected together. It produces an electric current by converting chemical energy into electrical energy. Also, a dry cell.

Battery Acid - Mixture of sulfuric acid and water used in a storage battery. Also called the battery electrolyte.

Battery Cell - Group of positive and negative plates, covered with electrolyte, in a compartment of the battery case separate from other elements. A cell of an automotive battery has a voltage of about 2.2 volts.

Battery Charge - Reverse chemical reaction that takes place when current is reversed through a battery to restore the metal in the plates and the electrolyte to their original condition.

Battery Charger - Rectifier used to change alternating current into direct current to send a reverse current through the plates of a battery to restore the chemical imbalance needed to produce electrical energy.

Battery Element - Group of positive and negative plates with separators and covered with electrolyte and contained in a battery cell.

Belt Tension - The tightness of a drive belt.

Biasing - Applying voltage to a junction of semiconductor materials.

Bimetal - Sensing device made from two metals with different heat expansion rates. Temperature changes cause the device to bend or distort. Activates another component.

Bimetallic - A substance made up of two metals bonded together.

Bonding - Process by which the electrons in the valence ring of one atom are shared with those of another.

Bound Electrons - Five or more tightly held electrons in an atom's outer ring.

Breakdown Voltage - Voltage applied to a diode or a transistor in the reverse direction from that in which it passes current. The voltage is large enough to cause a massive failure to hold back current. Breakdown voltage is also that applied to a zener diode to allow a reverse current flow through the diode.

Brushes - Bars of carbon, or other conductive material, that make an electrical connection with the rotating commutator or slip rings.

Buss Bar - A solid metal strip, or bar, used as a conductor in a fuse panel.

C

Cable - Conductor made from a number of wires twisted together.

Capacitance - The ability of two conducting surfaces, separated by an insulator, to store an electric charge.

Capacitor - Electrical component used to store and release a current through a secondary circuit. Can be used to protect a circuit against surges in current, store and release a high voltage, or smooth out current fluctuations. Also called a condenser.

Capacity Test - Test of a battery's condition by applying a heavy load (300 amp) to the battery for a brief time (15 seconds) then measuring the voltage.

Carbon Pile - A pile, or stack, of carbon disks enclosed in an insulating tube. When the disks are pressed together, the resistance of the pile is decreased.

Cathode - The negative terminal of a semiconductor toward which the current flows.

Cell - A dry cell, e.g., a flashlight battery. In a storage (wet cell) battery, one of the sets of positive and negative plates which, with electrolyte (sulfuric acid and water), produces electricity. Each cell can produce about 2.2 volts.

Cell Gassing - The emission of hydrogen gas from battery cells during charging.

Central Processing Unit (CPU) or Microprocessor - The processing and calculating portion of a microcomputer.

Charge (Recharge) - To restore the active materials in a battery cell by electrically reversing the chemical action.

Charging System - Components to restore electrical potential in the battery and supply the current needed to meet the electrical demands of the vehicle.

Circuit - A combination of elements physically connected to provide an unbroken flow of electrical energy from a power source through a conductor to a working device, and through a return conductor, back to the power source.

Circuit Breaker - Device used to open an electric circuit when overheated to prevent damage by excess current flow.

Circuit Diagram - Drawing showing the wires, connections and components (loads) in an electric circuit.

Closed Circuit - A circuit which is uninterrupted from the current source and back to the current source.

Cold-Cranking Rating - A battery rating based on the amperes of current that a battery can supply for 30 seconds at 0°F, with no battery cell falling below 1.2 volts.

Collector - The area of a transistor which collects emitted electrons and then passes them on through a conductor completing a circuit.

Color Coding - The use of colored insulation on wire to identify an electrical circuit.

Commutator - That part of a starter motor where current is sent to the rotating coils in the armature. It is the rotating connector between the armature windings and the brushes. It consists of copper bars at one end of the starter motor armature electrically insulated from the shaft and insulated from each other by mica.

Compound Motor - A motor that has both series and shunt field windings. Often used as a starter motor.

Computer Control - Control of any automotive system using solid state devices and operating with a preprogrammed set of commands (program), sensors to monitor various engine conditions (input), and signals set to affect the function of some component (output). Also holds commands in memory for later use.

Condenser - Electrical component used to store and release a current through a secondary circuit. Can be used to protect a circuit against surges in current, store and release a high voltage, or smooth out current fluctuations. Also called a capacitor.

Conductivity - Measure of how easily an electrical component conducts current.

Conductor - Any material that allows electric current or heat to flow. Current flows easily through a conductor because there are many free electrons.

Constant Voltage Charging - Method of charging battery in which a constant voltage is applied and the current decreases as the battery approaches the charged condition.

Continuity - Continuous, unbroken. Used to describe a working electrical circuit or component that is not open.

Control Circuit Resistance Test - Test used to determine if there is high resistance in the control circuit that will reduce current flow through the starter solenoid or relay windings and cause improper operation of the starter circuit.

Conventional Theory - The current flow theory which says electricity flows from positive to negative. Also called the positive current flow theory.

Copper - A metal used for electrical conductors because it has less resistance than most other metals.

Counterelectromotive Force - An induced voltage that opposes the source voltage and any change (increase or decrease) in the charging current. Abbreviated: CEMF.

Cranking - The act of engaging the starter by turning the ignition switch to make the engine turn over.

Cranking Circuit - Motor feed and ground circuits required to supply heavy current to the cranking or starter motor.

Cranking Circuit Resistance Test - Test used to determine if there is excessive electrical resistance in the cranking circuit preventing full power from reaching the starter motor.

Current - Flow of electrons through a circuit, measured in amperes.

Cutout Relay - A relay that keeps the battery from discharging when the engine is off or idling. It acts as a circuit breaker to open the circuit between the battery and alternator.

Cycle - Any series of events repeating continuously. In electrical system the flow of current alternates first in one direction and then in the opposite direction.

Cycling - Battery electrochemical action. One complete cycle is the operation from fully charged to discharged and back to fully charged.

D

D'Arsonval Movement - A small, current-carrying coil mounted within the field of a permanent horseshoe magnet. Interaction of the magnetic fields causes the coil to rotate. Used as a measuring device within electrical gauges and test meters.

Defective Device - A type of circuit malfunction in which a component of electrical circuit does not work as it should. This could be a worn-out battery, corroded switch, burned-out lamp bulb, or broken connector.

Delta-Type Winding - An alternator stator design in which the three windings of a 3-phase alternator are connected end-to-end. The beginning of one winding is attached to the end of another winding. Used in alternators that must give high-amperage output.

Dielectric - The insulating material between the two conductive plates of a capacitor.

Digital - Method of sending information through an electrical circuit by switching the current on or off.

Digital Computer - A computer that uses numbers to perform logical and numerical calculations, usually in a binary (two digits) numbering system. Faster and superior performance to an analog computer.

Digital Readout - A display of numbers or a combination of numbers.

Diode - A semiconductor device made of P.-material and N-material bonded at a junction. It permits current to flow in one direction only, and is used in rectification (changing alternating current to direct current).

Diode Trio - Six diodes, arranged in pairs front to back, each at the end of a stator winding in an alternator. Used to rectify both phases of an alternating current cycle to direct current.

Direct Current (DC) - A steady flow of current moving continuously in one direction along a conductor from a point of high potential to a point of lower potential.

Doping - Addition of a small amount of a second element to a semiconductor element to change its electrical characteristics.

Drive Belt - A flexible belt connecting the fan and the alternator, causing both to turn through a pulley system at the end of the crankshaft.

Dry Cell - Voltage source consisting of three elements: a zinc cylinder, a paste of electrolyte, and a carbon rod or electrode.

E

Eddy Current - Currents in armatures, pole pieces, and magnetic cores induced by changing electromotive force. It is wasted energy and creates heat.

Effective Resistance - All electrical and inductive losses of a cd

Electrical Balance - An atom or an object in which positive and negative charges are equal.

Electrical Charge - Property of electrons and protons that give a substance its electrical characteristics. A deficiency of electrons in the outer ring of atoms of a substance will give it a positive charge. An excess will give the substance a negative charge.

Electrical Symbols - Simple drawings used to represent different parts of an electrical circuit.

Electrical System - Parts of the vehicle that crank the engine for starting, furnish high voltage sparks in the cylinders, operate lights and accessories, and charge the battery. Electrical systems of a diesel include circuits to operate the glow plug system.

Electricity - The controlled movement of electrons in a conductor.

Electrochemical Device - A device that operates on both electrical and chemical principles (a lead-acid storage battery, for example).

Electrochemistry - In a battery, voltage caused by the chemical action of two dissimilar materials in the presence of a conductive chemical solution.

Electrolyte - A solution of sulfuric acid and water used in a storage battery that through chemical reaction produces electric potential.

Electromagnet - Coil of current-carrying wire usually wound around a soft iron core that becomes magnetized when current passes through the wire and demagnetized when the current stops.

Electromagnetic Field - The invisible field of force which surrounds a charged conductor or coil.

Electromagnetic Induction - The creation of a voltage within a conductor when relative motion exists between the conductor and a magnetic field.

Electron - Those parts of an atom which are negatively charged and orbit around the nucleus of the atom.

Electron Flow Theory - Belief that current flow consists of electrons flowing from a point with a high potential of free electrons (negative) to a point with fewer electrons (positive).

Electronic - Any system using integrated circuits or semiconductors to control the flow of current. As opposed to electrical that describes systems in which there are no solid state components and devices are controlled by current applied to such components as motors, solenoids, and relays.

Electron Theory - States that all matter is made up of atoms which are made up of a nucleus and orbiting electrons. The “free” electrons can move from one atom to another, producing electricity.

Electrostatic Field - The area around an electrically charged body resulting from the difference in voltage between two points or surfaces.

Element - A substance that cannot be further divided into a simpler substance. In a battery, a group of positive and negative plates, separated by insulators that make up each cell.

Emitter - Region in a transistor that emits (NPN) or collects (PNP) large number of electrons as a small number of electrons are taken from or added to the base.

Energize - To put energy into. The iron core of an electromagnet is energized by passing current through the coil.

Equivalent Resistance - The total resistance of a parallel circuit. The single mathematical equivalent of all the parallel resistances.

F

Farad - The unit of measurement of capacitance.

Feedback System - Electronic system in which sensors monitor the output of various automotive systems and provide input to control the operation of the system and change the output. It is a self-correcting system.

Feed Circuit - Line supplying all the branch circuits with the main supply of current. Generally used to refer to the hot (not grounded) feed from the battery to the electrical components of a vehicle.

Field Coil - Winding of current-carrying conductors used in a starter motor to produce a magnetic field.

Field Magnet - A magnet for producing and maintaining a magnetic field especially in an alternator or electric motor.

Field Relay - A magnetic switch used to open and close the alternator field circuit, or in a charging circuit with a warning lamp, to control the lamp circuit.

Field Strength - The density of magnitude of the magnet lines of force. The denser the magnetic field, the more lines of force will extend from pole to pole in the magnet and the stronger the field will be.

Field Windings - Insulated wire wrapped around an iron or steel core. When current flows through the windings, a strong magnetic field is created.

Filament - A resistance in an electric light bulb which heats up and glows, producing light, when an adequate current (bombardment by electrons) is sent through it.

Flux - The lines of magnetic force flowing in a magnetic field.

Flux Density - The number of flux lines in a magnetic field area. The more flux lines in a unit of area the stronger the magnetic field at that point.

Forward Bias - The application of a voltage to produce current flow across the junction of a semiconductor.

Free Electron - An electron in the outer orbit of an atom, not strongly attracted to the nucleus, and can therefore be easily forced out of its orbit into orbit around the nucleus of another atom.

Frequency - Number of times every second an alternating current goes through a complete cycle. Now measured in units of hertz (Hz) but previously measured in cycles per second (cps).

Full-Wave Rectification - A process by which all of an A.C. voltage wave is rectified and allowed to flow as D.C.

Fuse - A device containing a soft piece of metal which melts and opens, or breaks, the circuit when it is overloaded. Similar in function to a "circuit breaker," but must be replaced after circuit problem is corrected.

Fusible Link - A short piece of wire soldered into a heavy feed circuit, designed to melt when an overload occurs. Performs the same function as a fuse or circuit breaker. Like the fuse, it must be replaced after the circuit problem is corrected.

G

Gassing - Escape from a battery of highly explosive hydrogen gas formed during charging.

Generator - An apparatus that produces an electric current through magnetism. Its A.C. (Alternating Current) output is internally changed to D.C. (Direct Current) through the commutator. The alternator, a type of generator, changes its A.C. output to D.C. through the use of diodes.

Germanium - A metalloid element used as a semiconductor material in transistors.

Glow Plug - A resistance heater, shaped somewhat like a spark plug, heated by low voltage current. Used to heat compressed air in a diesel engine until the heat of combustion reaches the temperature to cause self-ignition without assistance.

Grid - Frame of a storage battery plate having spaces in which the active material in paste form is pressed.

Ground - The return path for current flow in a circuit. In automotive use, the circuit ground path is usually the vehicle frame and metal body parts.

Ground Cable - The battery cable that provides a ground connection from the vehicle chassis to the battery.

Grounded Circuit (Unintentional) - A type of circuit malfunction in which the current in the circuit is accidentally shunted, or diverted to ground. Usually, this condition bypasses a load. If a load is bypassed, it reduces the resistance of the circuit and can cause wiring to overheat, fuses to blow, etc.

Ground-Seeking - A test method using a 12-volt test light where one lead is connected to a known power source and the other lead is touched to various points of a circuit to seek a point where the circuit is grounded.

Ground Terminal - The terminal of the battery connected to the metal frame and chassis of the vehicle for the return path of current flow back to the battery, usually to the negative terminal.

H

H₂O - Chemical symbol for water.

H₂SO₄ - Chemical symbol for sulfuric acid.

Half-Wave Rectification - A process by which only one-half of an A.C. voltage wave is rectified and allowed to flow as D.C.

Heat Sink - Device to absorb heat from one medium by transferring it to another. Diodes in alternators are mounted on heat sinks to prevent the diodes from overheating,

High Rate Discharge Test - Battery test in which the battery is discharged at a high rate of current while cell voltages are checked.

High Resistance - A type of circuit malfunction in which a loose, dirty or corroded connection limits current flow below specifications. The result can be dimmed lamps, flickering lamps, or even inoperative devices.

Hold-In Winding - The coil of small-diameter wire in a solenoid that creates a magnetic field to hold the solenoid plunger in position inside the coil.

Hole - The space in a valence ring where another electron could fit.

Hydrogen - (H) Colorless, odorless, highly flammable gas. Simplest and lightest element having only one electron orbiting around the nucleus.

Hydrometer - Device used to measure the weight of a liquid, or its specific gravity. Used to measure the acid content of electrolyte in batteries or the ethylene-glycol content of coolant.

I

Ignition - Action of the spark in starting the burning of the compressed air/fuel mixture in the combustion chamber.

Ignition Coil - An induction coil used to produce a high voltage current to jump the gap in a spark plug and ignite the air/fuel mixture in the combustion chamber. A small voltage turned on and off in the primary windings induces a much larger voltage as the output from the secondary winding.

Ignition Resistor - A resistance in the primary ignition circuit to reduce the amount of battery voltage available at the coil.

Ignition Switch - Switch used to open and close the circuit to the primary ignition coil. Also used to open and close accessory circuit on the vehicle.

Ignition System - System to furnish high voltage sparks to the cylinders to ignite the compressed air/fuel mixture at the right time. Consists of the battery, ignition coil, distributor, ignition switch, wiring and spark plugs.

Impurities - The doping elements added to pure silicon or germanium to form semiconductor materials.

Indicator - Device used to make some condition known by use of a light or gauge.

Indicator Light - An illuminated warning or indicator to the driver of a vehicle of some condition, such as when the alternator is not supplying current or when the coolant temperature is close to overheating.

Induced Voltage - The voltage which appears in a conductor when relative motion exists between it and magnetic flux lines.

Induction - Producing a voltage in one conductor or coil by moving the conductor or coil through a magnetic field or by moving the magnetic field past the conductor or coil.

Infinite Reading - A reading (∞) on an ohmmeter that indicates an open circuit - broken wire, defective component.

Infinite Resistance - Very high resistance, a value higher than can be conceived. No current can move through. Usually, circuit is broken with no complete path for current flow.

Initial Charge Rate - The current a battery will accept at the start of charging. Charging current decreases as charging progresses.

Input - Generally used to refer to the data or instructions given or fed into a micro-computer.

Insulated Cable - The battery cable that conducts battery current to the automotive electrical system.

Insulators - Materials that will not conduct electron flow because of their many bound electrons.

Integrated Circuit - (IC) An electronic circuit containing transistors, diodes, resistors, and capacitors along with electrical conductors processed and contained entirely within a single chip of silicon.

Ion - An atom which has become unbalanced by losing or gaining an electron. It can be positively or negatively charged.

Ionize - To break up molecules into two or more oppositely charged ions. The air gap between the spark plug electrodes is ionized when the air/fuel mixture is changed from a nonconductor to a conductor.

J

Jump Starting - Using a booster battery to start a vehicle in which the battery does not have sufficient charge to start the vehicle itself.

Jumper Wire - A test device or tool used by technicians to create a temporary bypass for current in a circuit. A jumper wire may be used to ground a circuit, to bridge a broken wire or switch, or to complete a circuit for test purposes.

Junction - The area where two types of semiconductor materials (P- and N-material) are joined.

K

K - Prefix used in the metric system of measurement to mean 1000 times the stated value. Abbreviation for kilo.

Kilowatt - Unit of power in the metric system. One kilowatt is equal to about 1.341 horsepower. Also used to describe 1000 watts of electrical power.

Knock Sensor - An acoustical device used to sense engine vibrations caused by self-ignition, or knock, and signal an electronic control module to adjust spark timing and reduce detonation.

L

Lead-Acid Battery - A common automotive battery in which the active materials are lead, lead peroxide, and a solution of sulfuric acid and water.

Lead Dioxide - Lead oxide material used in the positive plates of storage batteries.

Lead Sulfate - Hard, insoluble layer that slowly forms on the plates of a discharged battery and can only be reduced by slow charging. Caused by the chemical reaction of the acid in the electrolyte acting on the lead peroxide and sponge lead of the active material in the plates.

Leakage Current - Unwanted current flowing through a semiconductor or capacitor.

Left-Hand Rule - A method of determining the direction of the magnetic flux lines surrounding a current-carrying conductor when the electron theory of current flow is used (- to +). If the conductor is grasped with the left hand so the thumb points in the direction of current flow, the fingers will point in the direction of magnetic flux.

Light Emitting Diode (LED) - A semiconductor diode designed so light is emitted when forward current is applied to the diode.

Light-Load Test - A test applied to storage batteries during which the voltage is measured while the battery is subjected to a light load, such as the car headlights.

Linear Integrated Circuit - An integrated circuit designed to amplify signals rather than switching.

Lines of Force - Imaginary lines representing the direction of magnetism around a conductor or from the end of a magnet.

Liquid Crystal Display (LCD) - Uses a polarized light principle and a liquid crystal to display numbers and characters.

Loss of Power - A type of circuit malfunction in which the voltage source for the circuit or device is lost. This could be a worn-out or defective battery or an OPEN CIRCUIT on the battery side of the electrical load.

M

Magnet - Any body with the property of attracting iron and steel. Temporary magnets are made by surrounding a soft iron core with a strong electromagnetic field. Permanent magnets are made with steel.

Magnetic Circuit - Paths taken by lines of force in going from one end of the magnet to the other.

Magnetic Field - The area near a magnet where the property of magnetism can be detected. Also the flow of magnetic force between opposite poles of a magnet.

Magnetic Flux - The invisible, directional lines of force which make up a magnetic field.

Magnetic Flux Density - Strength of the magnetic lines of force. The denser the magnetic flux, the more lines of force will extend from pole to pole in the magnet.

Magnetic Induction - Producing magnetism in a magnetic body by bringing it near a magnetic field.

Magnetic Pole - Point where the lines of force enter and leave a magnet.

Magnetic Saturation - The condition when a magnetic field reaches full strength and maximum flux density.

Magnetic Shunt (Magnetic Bypass) - A piece of metal on a voltage regulator coil that controls voltage output at varying temperatures by affecting the coil's magnetic field.

Magnetism - A form of energy caused by the alignment of atoms within certain materials. The ability of a metal to attract iron.

Maintenance-Free Battery - Battery that does not require the addition of water during its normal service. Grids in maintenance-free batteries are made of metals other than antimony to produce less gassing and therefore, less chance of pushing electrolyte from the battery.

Matter - The substance of which a physical object is composed.

Memory - Part of a microprocessor or microcomputer in which instructions or data are stored as electrical impulses.

Micro - Prefix of measurement meaning one millionth of a part.

Microprocessor - Set of integrated circuits that can be programmed with stored instructions to perform given functions. A computer in the lowest range of size and speed containing a central processing unit (CPU), instructions stored in a read only memory (ROM), and a random access memory (RAM) for receiving data and instructions. Also called a microcomputer.

Milli - Prefix of measurement meaning one thousandth of a part.

Millisecond - Unit of measurement for time, meaning one thousandth of a second.

Module - A self-contained, sealed unit that houses the solid-state circuits needed to control certain electrical or mechanical functions.

Molecule - Two or more atoms joined together to form an element or a chemical, compound.

Motor - An electromagnetic device used to convert electrical energy into mechanical energy.

Mutual Induction - Creation of voltage in one conductor by the rise and collapse of the magnetic field surrounding another conductor. Magnitude or strength of Induced voltage depends on the ratio of turns between one coil and the other and the strength of current causing the induced voltage.

N

Nanosecond - One billionth-of a second. A unit of measurement usually referring to the speed the circuit in a microcomputer can work.

Electricity, traveling at the speed of light, will travel about 11.8 inches in one nanosecond. In comparison the same electricity will travel about 930 feet in one microsecond (millionth of a second).

Negative Polarity - Also called ground polarity. A correct polarity of the ignition coil connections. Coil voltage is delivered to the spark plugs so that the center electrode of the plug is negatively charged and the grounded electrode is positively charged.

Negative Pole - The point to which the electrons forming an electric current return from a circuit. Also referred to as the south pole in magnetism.

Negative Temperature Coefficient - The property of any substance in which the electrical resistance increases as the temperature of the substance decreases.

Negative Terminal - The battery terminal closest to the negative potential in the battery.

Neutral Junction - Center connection of the three windings in a Y-type alternator stator.

Neutron - A particle in an atom that has no charge and is electrically neutral.

N-Material - A semiconductor material that has excess free electrons because of the type of impurity added. It has a negative charge and will repel additional electrons.

No-Load Test - A cranking-motor test in which the cranking motor is operated without load; the current draw and armature speed at the specified voltage are noted.

North Pole - The area of a magnet from which the lines of force are said to leave the magnet. The end of a magnet that will point toward the north if freely suspended.

NPN Transistor - Transistor with two layers of N-type material separated by a layer of P-type material. Base circuit must be positive relative to the emitter for current to flow through the collector circuit.

N-Type Material - Semiconductor material with an excess of free electrons because of some impurity added. It has a negative charge and will repel additional electrons.

Nucleus - The center core of an atom that contains the protons and neutrons.

O

Ohm - The standard unit for measuring the resistance to current flow. One ohm of resistance will limit current flow to one ampere when one volt of pressure is applied.

Ohm's Law - The mathematical relationship between voltage, current, and resistance. The pressure of one volt applied to one ohm of resistance will cause one ampere of current to flow. Amps equal volts divided by ohms ($I = E/R$). Volts equal amps times ohms ($E = I \times R$). Ohms equal volts divided by amps ($R = E/I$).

Ohmmeter - An electrical meter used to measure the resistance to current flow in a circuit or working load. It reads ohms of electrical resistance. The ohmmeter can only be connected across a circuit or device with the power removed. This meter has its own battery and will be damaged if connected to a circuit that has power applied.

Open Circuit - A type of circuit in which there is an incomplete path for current flow. The open circuit may be caused deliberately, by a switch that is in the OFF position, or it may be caused by a break in the conductor. An open circuit can occur on either side of the load; however, an open circuit in the ground side of the circuit is usually referred to as a LOSS OF GROUND.

Open-Circuit Voltage - The voltage across the battery terminals with no load applied.

Oscilloscope - An electric instrument producing, on a screen, a visual display or trace of voltage changes in an electrical circuit.

Overcharging - Continued charging of a storage battery after it has reached the fully charged state. This damages the battery and shortens its life.

Overload - Carrying a greater load than the device, machine, or electric circuit is designed to carry.

P

Parallel Circuit - A circuit in which the components are arranged so that there is a separate current path to each component. In a parallel circuit, the components are connected positive-to-positive and negative-to-negative.

Peak Inverse Voltage - Highest reverse bias voltage that can be applied to a junction of a diode before the semiconductor material breaks down and allows current to flow in the opposite direction.

Permanent Magnet - Piece of metal that holds its magnetism without the use of continuing electric current to create a magnetic field.

Permeability - A measure of the ease or difficulty with which materials can be penetrated by magnetic flux lines. Iron is more permeable than air.

Photoelectricity - Voltage caused by the energy of light as it strikes certain materials.

Piezoelectricity - Voltage caused by physical pressure applied to the faces of certain crystals.

Plate - Material in a storage battery that reacts with the acid in electrolyte to produce a voltage for current flow. Usually made of a soft porous lead compound supported by a harder metal grid. If the plate is sponge lead it has a positive charge; if it is made of lead peroxides, it has a negative charge.

Plate Group - The positive and negative plates in one cell of a battery, connected together to produce approximately 2.2 volts.

PN Junction - Dividing line in a semiconductor between P-type material and N-type material. Electrons can flow from N to P but not from P to N.

PNP Transistor - Transistor with two layers of P-type material separated by a layer of N-type material. Base circuit must be negative relative to the emitter for current to flow through the collector circuit.

Polarity - The quality or condition in a body that has opposite properties or directions. A collective term applied to the positive (+) and negative (-) ends of a magnet or electrical component such as a battery or coil.

Polarize - The process of establishing positive and negative polarity across alternator fields and thus determining the direction of current flow.

Polarizing - A method of maintaining the electrical and magnetic polarity of the pole shoes and field in an alternator.

Poles - Positive and negative terminals of a cell or battery. Also, the ends of a magnet (north and south).

Pole Shoes - Magnetic iron cores, or poles, that provide the magnetic field in an alternator or motor and strengthen the electromagnetic field of the field windings.

Positive Charge - The electrical characteristics of a substance with a deficiency of electrons in the outer ring of its atoms.

Positive Plate - The dioxide of lead plate in a lead-acid storage battery.

Positive Polarity - Also called reverse polarity. An incorrect polarity of the ignition coil connections. Coil voltage is delivered to the spark plug so that the center electrode of the plug is positively charged and the grounded electrode is negatively charged.

Positive Pole - The point from which the electrons forming an electric current enter a circuit as defined by the "Conventional Theory." Also referred to as the north pole in magnetism.

Positive Temperature Coefficient (PTC) - Resistor or heating element in which the resistance increases with temperature, heat created by current flowing through it. Eventually the resistance will get so high that it will oppose all current flow. Then, the resistor or heating element will cool down until current can begin to flow again, increasing the temperature.

Positive Terminal - The battery terminal from which electrons flow in a complete electrical circuit. Generally the side of the circuit not connected to ground.

Potential - The pressure (voltage) existing between two points available to force electrons through the circuit as current.

Potentiometer - Electrical component that can vary the amount of resistance placed in a circuit by turning or sliding a contact on the resistance wire windings.

Power - Rate at which work is done. Common unit of measure for power is horsepower. Power is also measured by kilowatt (kW). About three-fourths of a kilowatt equal one horsepower.

Power Feed Circuit - Wires that carry current from the positive terminal of the battery to the electrical components of the vehicle.

Power-Seeking - A test method using a 12-volt test light where one lead is connected to a known ground and the other lead is touched to various points of a circuit to seek a point where power is present.

Power Supply - Sources of voltage in a circuit.

Preglow - The time it takes a glow plug to reach a temperature at which it will cause ignition of the mixture in the cylinder.

Primary Winding - Winding of relatively heavy wire in an ignition coil that receives current from the battery to create a magnetic field and induce a voltage in the secondary windings of the coil.

Primary Wiring - The low-voltage wiring in an automobile electrical system.

Printed Circuit - An electrical circuit made by etching a conductive material on an insulated board into a pattern to provide current paths between components mounted on the board.

Programmable Read-Only Memory (PROM) - Part of a microprocessor or computer in which instructions or data are semipermanently located. PROM data can be changed (like a RAM) but are not volatile memory (they do not erase when the power is turned off but are permanently configured as part of the electronic circuit).

Proton - One of the positive-charged particles in the nucleus of an atom.

P-Type Material - Semiconductor material with holes as part of its basic structure. It has a positive charge and will attract additional electrons.

Pull-In Winding - The coil of large-diameter wire in a solenoid that creates a magnetic field to pull the solenoid plunger into the coil.

Q

Quick Charger - Battery charger used to produce a high charging current to boost the charge of a battery in a short time.

R

Random Access Memory (RAM) - Part of a microprocessor or computer into which information can be written and from which information can be read.

Reactance - Property of an electrical device or conductor to impede change in current passing through it or voltage exerted on it.

Read-Only Memory (ROM) - Part of a microprocessor or computer where information and instructions are permanently integrated into the circuits and can only be read by the processor. Usually used to store the program or instructions for the processing unit to act on.

Rectifier - Device used to change alternating current to direct current.

Regulator - Device in the charging system used to control alternator output to prevent excessive voltage from being fed to the battery or to the electrical components in a vehicle.

Relative Motion - Movement of a conductor in relation to magnetic flux lines or movement of magnetic flux lines in relation to a conductor.

Relay - An electromagnetic switch. A relay uses a small amount of current flow to control the flow of a larger amount of current through a separate circuit.

Reluctance - The tendency of some materials to resist penetration by magnetic flux lines.

Required Voltage - Voltage needed to fire a spark plug.

Reserve Capacity Rating - A battery rating based on the number of minutes a battery at 80°F can supply 25 amperes, with no battery cell falling below 1.75 volts.

Resistance - The opposition to the free flow of an electric current, measured in ohms.

Resistor - A device made of carbon or wire that presents a resistance to current flow. Any device in a circuit that produces work, loads the circuit, and causes a voltage drop acts as a resistor.

Resistor Plug - A spark plug with a resistor in the center electrode to reduce the inductive portion of the spark discharge. Used to minimize radio and television interference caused by spark plugs.

Resistor Wire - Conductor of a given diameter and length that adds resistance, usually a low value, to a circuit.

Reverse Bias - Polarity of voltage applied to the junctions of a diode or transistor so normally no current will flow across the junction.

Reverse Breakdown Voltage - The reverse voltage beyond which a diode cannot hold back reverse current.

Reverse Current - Amount of current flowing from cathode to anode when a given reverse voltage is imposed on a diode or transistor.

Rheostat - A resistor for regulating a current by means of variable resistances.

Right-Hand Rule - A method of determining the direction of magnetic flux lines surrounding a current-carrying conductor, when the conventional theory of current flow is used (+ to -). If the conductor is grasped with the right hand so the thumb points in the direction of conventional current flow, the fingers will point in the direction of magnetic flux.

Rotor - Revolving part of a device, such as an alternator rotor, distributor rotor, or rotary combustion engine rotor.

S

Schematic Diagram - A drawing of a circuit, or any part of a circuit, that shows how it works.

Secondary Circuit - High voltage circuit of the ignition system consisting of the coil, rotor, distributor cap, spark plug cables, and spark plugs.

Secondary Winding - The coil winding made of many turns of a fine wire, in which voltage is induced by the rise and collapse of the magnetic field of the primary winding.

“See-Saw” Rule - An easy way to remember and use Ohm’s Law in your work. If voltage stays the same, but current is above specs, **resistance must be down** - possibly a short circuit. If voltage stays the same, but current is below specs, **resistance must be up** - possibly a bad connection.

Self Discharge - Chemical activity in a battery causing the battery to discharge even though it is not supplying a circuit or component with current.

Self-Induced Voltage - Voltage created in a conductor by the magnetic lines of a current through that same conductor.

Self-Powered Test Light - Used to check for continuity in a circuit or load device. Test unit uses a low voltage battery (1.5 volts) and bulb, and test leads.

Semiconductor - Popular name associated with almost any solid state circuit or component. Materials with four electrons in the outer ring of the atom which show the properties of a conductor or a nonconductor under different conditions.

Sending Unit - Sensor in the engine at a convenient point of an oil gallery or coolant passage to send a signal to a gauge or light indicating the pressure or temperature of the oil or coolant.

Series Circuit - A circuit in which the parts are connected end to end, positive pole to negative pole, so that only one path is available for all current flow.

Series Motor - A motor that has only one path for current flow through the field and armature windings. Commonly used for starter motors.

Series-Parallel Circuit - The connection of several loads in a circuit in such a way that current must flow through some loads, but can flow to one or more other loads without affecting the rest of the circuit. A series-parallel circuit is simply a circuit containing elements of both a series circuit and a parallel circuit.

Short Circuit - A type of circuit malfunction in which two or more wires touch each other accidentally, in such a way that the circuit(s) are completed wrong. A short circuit between two different circuits interconnects the two in such a way that if either circuit is electrically energized, both will function.

Shunt - Parallel. An electrical connection or branch circuit in parallel with another branch circuit or connection.

Shunt Motor - A motor that has its field windings wired in parallel with its armature. Not used as a starter motor, but often used to power vehicle accessories.

Silicon - Element commonly used in making semiconductor material.

Sine Wave Voltage - The constant charge, first to a positive peak and then to a negative peak, of an induced alternating voltage in a conductor.

Single-Phase Current - Alternating current caused by a single-phase voltage.

Single-Phase Voltage - The full wave voltage induced within one conductor by one revolution of an alternator rotor.

Slip Rings - Parts of an alternator forming a rotating connection between the field coil windings and the brushes.

Solenoid - Electromechanical device used to produce mechanical movement by drawing a plunger into a coil when current is applied to the coil. Used to control a valve, switch contacts, or control other moving parts.

Solenoid-Actuated Starter - A starter that uses a solenoid both to control current flow in the starter circuit and to engage the starter motor with the engine flywheel.

Solid State - Electronic components consisting mainly of silicon chips and similar conductive materials.

Solid State Regulator - Voltage regulator made from semiconductor components mounted in the alternator.

Solid Wire - A conductor made of one piece instead of being made from a number of smaller wires.

South Pole - Area of a magnet where the magnetic lines of force converge and enter the magnet.

Spark Plug - Device used to provide the heat or flame to ignite compressed air/fuel mixture in the combustion chamber. Consists of two accurately spaced electrodes and a threaded outer shell to screw into the cylinder head.

Specific Gravity - Weight of a substance compared to the weight of water. Any substance with a specific gravity of less than 1.00 is lighter than water; more than 1.00 is heavier than water. The amount of another substance (such as battery acid or antifreeze) in water can be determined by measuring the specific gravity of the mixture.

Sponge Lead - Porous lead used as the active material of the negative plate of a lead-acid storage battery.

Starter Motor - Electric motor used to crank the engine for starting.

Starter Motor Load Test - Test used to identify internal problems in the starter motor.

Starter No-Load Test - Test used to uncover such faults as open or shorted windings, rubbing armature, and bent armature shaft.

Starter Relay - Electrical switch on the starter motor that uses a smaller current from the ignition circuit to control a larger current from the battery to the starter motor.

Starter Solenoid - An electrically operated plunger mechanism on the starter motor used to engage the starter pinion gear with the ring gear on the flywheel. Also used to control the current to the starter motor.

Starting Bypass - A parallel branch circuit that bypasses the primary ballast resistor during cranking.

Starting Control Circuit Test - Test used to determine whether failure to crank is due to open circuits, defective wiring, or poor connections causing excessive resistance in the starter control circuit.

Starting Safety Switch - A neutral start switch. It keeps the starting system from operating when a car's transmission is in gear.

Starting System - Components in the electrical system used to crank the engine until it can begin running on its own.

State-of-Charge - A measurement of a battery's internal condition in relation to a fully charged unit, usually expressed as a percentage of full charge.

Static Electricity - Voltage resulting from the transfer of electrons from the surface of one material to the surface of another material. The electrons are "static," meaning at rest.

Stator - In an alternator, it is the part which contains the conductors within which the field rotates.

Storage Battery - Device used to change chemical energy into electrical energy. Part of the electrical system acting as a reservoir for electrical energy, storing it in a chemical form.

Stranded Wires - Wires or cables made of a number of smaller wires twisted or braided together.

Sulfation - The crystallization of lead sulfate on the plates of a constantly discharged battery.

Sulfuric Acid - Highly corrosive chemical compound used in a diluted form as the electrolyte in storage batteries.

Switch - A device used for opening, closing, or changing the connections in an electric circuit.

Symmetrical - The same on either side of center. In a symmetrical high-beam headlamp, the light beam is spread the same distance to either side of center.

System Diagram - A drawing that shows all of the different circuit diagrams in a complete electrical system.

T

Temperature Correction - The amount that must be added to or deducted from a reading taken at one temperature to make it comparable with the same reading taken at a standard temperature.

Terminal - A device attached to the end of a wire or to an apparatus for convenience in making electrical connections.

Test Lamp - A 12-volt lamp with leads (wires) attached so that the lamp can be temporarily inserted in an electrical circuit, either in series or in parallel with it. It is used to confirm that voltage is available to a specific point in a circuit.

Thermistor (Thermal Resistor) - A resistor especially built to reduce its resistance as the temperature increases.

Thermoelectricity - Voltage resulting from an unequal transfer of electrons from one metal to another, when one of the metals is heated.

Three Phase Current - Combination of three alternating current cycles, each starting one-third of a cycle apart so each of the cycles in the resulting combined wave is 120 degrees out of phase from the others. Provides a smoother direct current flow when rectified because voltages of each alternating cycle are not allowed to decay completely before the next cycle begins to rise.

Thyristor - A silicon-controlled rectifier (SCR) that normally blocks all current flow. A slight voltage applied to one layer of its semiconductor structure will allow current flow in one direction while blocking current flow in the other direction.

Transducer - A device that changes one form of energy into another. In an ignition system, it may sense a mechanical movement and change it to an electrical signal.

Transformer - Device used to change alternating current from one voltage to another. Consists of two coils, one with more windings than the other, that induce voltage in one coil when current flows to the other. Can increase or decrease applied voltage.

Transistor - A semiconductor device with three connections. A small current at the control junction between semiconductor materials is used to control a larger current between two rectifying junctions.

Trickle Charge - A low rate of charge given to a storage battery over a long period of time.

Twenty Hour Rate - Battery rating measuring the amount of current a battery can deliver for 20 hours with an electrolyte temperature of 80°F (27°C) before the cell voltage drops to 1.75 volts.

V

V - Abbreviation for volt, a unit of measurement for electrical potential.

Vacuum Fluorescent Display (VFD) - Process of displaying numbers and letters by using free electrons from a heated filament striking a phosphor-coated material emitting a blue-green light. Used in many electronic display devices.

Valence Ring - The outermost electron shell of an atom.

Volt - The unit for measuring current pressure in a circuit. One volt of pressure causes one ampere of current to flow against one ohm of resistance.

Voltage - The electromotive force that causes current flow. The potential difference in electrical force between two points when one is negatively charged and the other is positively charged.

Voltage Drop - The difference in potential (voltage) between one point in a circuit and another; typically the voltage difference from one side of a component to the other.

Voltage Leak - The loss of charge in a capacitor because of the imperfect insulating characteristics of the dielectric, allowing voltage to “leak” across, neutralizing the electrical charge,

Voltage Loss (Also Called Voltage Drop) - Reduction in voltage across an electrical device or circuit because of the resistance to current flow of that device or circuit.

Voltage Regulator - A relay that limits an alternator’s voltage output.

Voltmeter - An electrical meter used to measure the difference in voltage between two points in a circuit. It reads volts of electrical pressure. The voltmeter must be connected across the load or circuit — red lead on the battery side of the circuit, black lead on the ground side of the circuit.

W

W - Abbreviation for watt, a unit of measurement for power.

Warning Light - Light that illuminates to alert the driver to some condition in the vehicle such as battery charging rate, high coolant temperature, or low oil pressure,

Watt - The unit of measurement for electric power. One way to measure the rate of doing work. Watts equal volts times amperes.

Watts Rating - A method of rating the available cranking power of a battery. The rating can be found by multiplying the current available from the battery by the battery voltage at 0°F.

Wire Gauge - Wire size numbers based on the cross section area of the conductor. Larger wires have lower gauge numbers.

Wiring Diagram - A schematic. The representation of an electrical circuit by a drawing. A wiring diagram may contain electrical symbols for various loads and components.

Wiring Harness - A bundle of wires enclosed in a plastic cover and routed to various areas of the vehicle. Most harnesses end in plug-in connectors. Harnesses are also called looms.

Y

Y-Type Winding - An alternator design in which one end of three windings is connected at a neutral junction.

Z

Zener Diode - A semiconductor made so it will allow reverse current flow without damage at a voltage above a specific value.